

X9S RC car remote control User Manual



WFLY

www.wflysz.com

Catalogue

Before Use	4
Product safety precautions	5
Safety Instructions	5
Package content	7
How to use the transmitter	8
Power on and off	9
Description of the home screen	9
Low voltage warning	10
Steering and throttle operation methods	10
How to operate the digital trim	11
How to adjust the trigger position	12
Wheel angle adjustment	13
Charging function	13
How to replace the battery	14
Trigger,wheel tightness adjustment method	14
How to operate a transmitter antenna	15
How to connect receiver and servo	16
Setup sequence for the model	18
Product feature	23
Base setting	24
Dual rate	24
Speed	25
Curve	28
Fail safe	34
Channel reverse	36
Sub trim	36
Trim setting	37
End point	38
End point	39
Channel limit	40
Throttle function	41
A.B.S	41
Throttle idle	45
Throttle mode	47
Throttle dead zone	49
Timer	50
Timer	51
Model timer	52

Model menu-	54
Select	54
Rename	54
Copy	56
Reset to user data	56
Send/Receive	57
Save user data	59
Reset to factory data	59
Quick setup	60
Advanced menu	62
Channel Setting	62
Throttle off	68
Steering mixing	69
Brake mixing	71
Gyro mixing	73
Condition	74
Program mixing	74
Tank mixing	77
Dual ESC	79
4WS mixing	80
Linkage menu	82
Servo view	82
Link	83
Receiver port setting	84
180°/270° servo	85
Servo type	86
System menu	86
User menu setting	86
Battery	88
Battery & Vibration	90
Voltage calibration	92
Sound and vibration	94
Telemetry voice	96

Display setting - - - - -	97
Home screen set - - - - -	99
LED setting - - - - -	101
Language - - - - -	101
Trainer and simulator - - - - -	102
Trigger and wheel calibration - - - - -	103
Information - - - - -	103
Touch and trim lock - - - - -	104
Factory reset - - - - -	104

Before Use

Precautions for safe use of 2.4GHz system

- Before use, please read the product manual and precautions in detail.
- 2.4GHz is not a dedicated frequency band for radio control. Because this frequency band is shared with the ISM frequency band used for short-distance communication, such as WiFi, Bluetooth, etc., please pay attention to this type of influence when using it. When signal interference occurs, stop using it immediately.
- When the signal is blocked by buildings, high-voltage lines or trees, it may cause the control response to become slow or uncontrollable. Please operate the model within visual range.
- For safety reasons, be sure to set the Fail-safe protection.

Precautions when installing 2.4GHz receiver

- When installing the receiver antenna, keep it away from metal as much as possible to ensure that there are no obstructions such as metal.

Notes for installation of 2.4GHz receiver

- When installing the receiver antenna, keep away from metal as far as possible and ensure that there is no metal or other shielding.
- Do not bend or damage the receiver antenna.

Safety Instructions

The meaning of the symbols

When the following icons appear in this manual, they indicate safety precautions, please pay special attention.

 **Danger** Indicates that if you ignore this sign and use it in the wrong way, it will cause the danger of death or serious injury to the user or others.

 **Warning** Indicates that if you ignore this mark and use it in the wrong way, it may cause death or serious injury to the user or others. In addition, minor injuries and property damage are likely to occur.

 **Attention** Indicates that if you ignore this sign and use it in the wrong way, the possibility of serious injury to the user or others is low, but there is still a risk of injury, and only property damage will occur.

Graphic meaning :  **Prohibited matters**

 **Matters to be observed**

 **Warning** Indicates that if you ignore this sign and use it in the wrong way, it may cause death or serious injury to the user or others. In addition, minor injuries and property damage are likely to occur.

 Driving is banned on rainy days, strong winds and at night.
After the transmitter enters the water, it may cause inability to operate, control or disorientation, resulting in loss of vehicle body control.

 Do not drive in the following places:

- Near crowds.
- Near high-voltage electricity or communication base stations.
- No matter if the vehicle body is out of control due to radio wave, obstacle interference or failure of the transmitter and the vehicle body, it may cause casualties to others.
- Do not drive when you are physically and mentally unwell or intoxicated.
- Inattentiveness, inability to judge correctly, easy to operate mistakes, and easy to cause danger.
- Before driving, you must test the functional status of the transmitting and receiving system and the power and control of the model.
- Abnormality in either the remote control or the model may cause loss of control.

Simple test method:

Ask the assistant to hold the model car or fix it on the platform, try to operate the movements of various parts, and confirm whether the movements are consistent with the instructions. Do not drive if it cannot be controlled or behaves abnormally. Also, confirm that the model parameters are consistent with the model. Do not touch the engine, motor, electronic transmission and other components immediately during or after use, as the model will generate high temperature and may cause burns.



When powered on:

With the transmitter's throttle trigger held in the stop position.

1. First turn on the power of the transmitter,
2. Turn on the power of the receiver again. When the operation is reversed, it may cause the vehicle body to lose control and be dangerous.

The transmitter's throttle trigger remains in the stop position.

1. First turn on the power of the transmitter

2. Turn on the power of the receiver again.

When the operation is reversed, it may cause the vehicle body to lose control and be dangerous.



When the power is turned off:

Stop the engine or motor

1. Turn off the power of the receiver first.

2. Turn off the power of the transmitter. If the operation is reversed, it may cause the danger of car body bursting in a short time. Before adjusting the remote control, please stop the engine running (the power supply of the motor is disconnected). If you do not stop the engine running first, the car body may burst and burst.

Warning Attention



Safety Precautions

Please confirm that the fail-safe protection function is normal before driving.

Confirmation method:

1. Turn on the transmitter first, then turn on the power of the receiver;

2. Set the failsafe function to the receiver (page 33);

3. Turn off the transmitter;

4. Confirm that the throttle and other channels will act at the set position under the runaway protection function. The runaway protection function is a safety auxiliary function that allows the servos to move at the preset position when the receiver cannot receive the signal, so as to minimize the damage. But if the preset location is a dangerous location, it will have the opposite effect.

But if the pre-set position is a dangerous position, it can have the opposite effect.

Example: It is safe to set the throttle to the neutral position.



Battery usage precautions



Before driving, be sure to keep the transmitter's battery fully charged. If the battery is insufficient while driving, there is a danger of losing control.

When the transmitter is powered by nickel-cadmium batteries, be sure to use a special charger. If the charging exceeds the specified value, abnormal heat generation, rupture, leakage of battery fluid will occur, resulting in burns, fire, blindness and other injuries.

Avoid short-circuiting the terminals of the battery. A short circuit may result in fire, abnormal heat, burns or fire.

Attention

Danger and safety matters





Avoid strong impact such as dropping the power supply battery from a high place. Strong impact on the battery will cause the battery to short-circuit, abnormally heat, and the damaged battery fluid may leak out, causing burns or chemical damage.

Be sure to disconnect the battery when not exercising.



When not charging, please unplug the charger, do not plug it into the socket. Avoid accidents caused by abnormal heat.

Precautions for storage and disposal of batteries

-  Do not place the transmitter, receiver, car body, etc. in a place where children can easily touch it. Children may be injured by touching the transmitter or the car body to make the car body run, or play with the battery and cause chemical poisoning.
-  Do not put the battery into fire or heat, nor disassemble or modify it. A ruptured battery, abnormal heat or leakage of battery fluid may cause burns or blindness.

-  Do not store the remote control in the following places. Extremely hot place (above 40°C) ~ extremely cold place (below -10°C)
 - Places exposed to direct sunlight
 - High humidity place
 - Dust place
 - Vibration place
 - A place with steamIf it is stored in the above-mentioned places, it will easily cause deformation or malfunction.

Other considerations

-  Do not let the plastic part come into direct contact with fuel, waste oil, exhaust, etc. If the plastic part comes into contact with fuel and other substances, it will corrode and cause damage. Other devices such as transmitters, receivers, steering gears, electronic transmissions, and nickel-cadmium batteries must be Use with regular products.

Before use, please be sure to understand the following information

When opening the package, please make sure that the following items are complete. The combination of matching parts is different, and the items are also different, please confirm according to the table below. The company is not responsible for any damage caused by the use of non-original products.

Package Content

- Transmitter (X9S) ×1 set
- Receiver (RG209S) × 1
- Simple manual ×1 sheet
- 18650 lipo battery compartment ×1
- Voltage detection line ×1

If the contents of the package are insufficient or unclear, please consult the model store where you purchased it.

How to use the transmitter

Names of radio parts

Tip: The functions of switches, buttons, trimming, etc. in the schematic diagram can be customized. The labels in the figure are the default functions set at the factory.

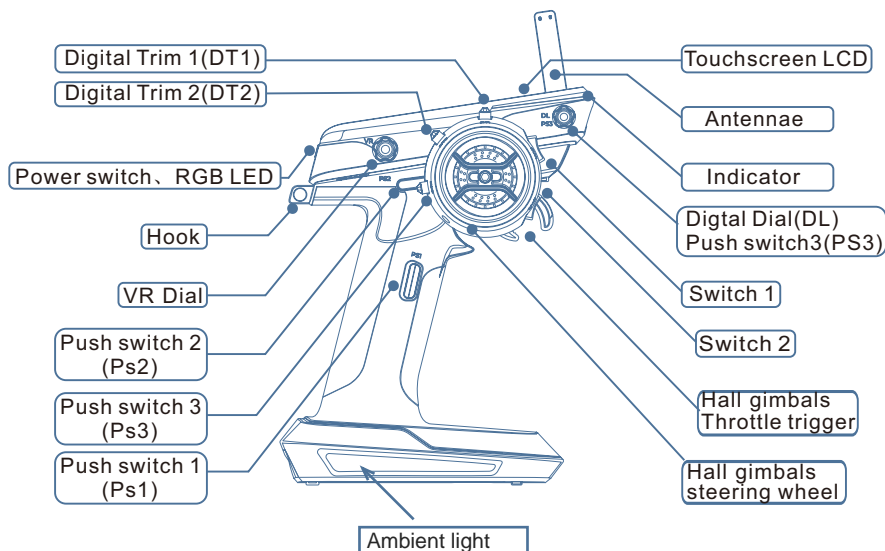

DL: Digital Dial(DL)
 Default : Dual Rate(Direction)
 PS3: Key Ps3
 DT1: Trim Dt1
 Default: direction trim
 DT2: Trim Dt2
 Default: Throttle trim
 DT3: Trim:DT3
 Default: brake rate

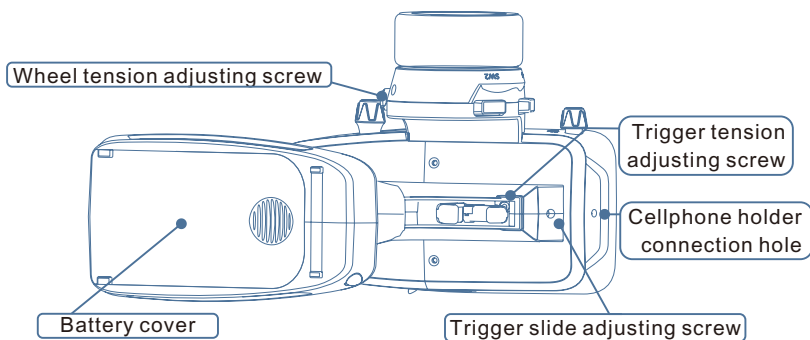

SW1 3-position switch Sw1
 Default: channel 4
 SW2 3-position switch Sw2
 Default: Channel 5
 Mobile phone bracket fixing hole
 Trigger position adjustment screw
 Trigger spring tension adjustment screw

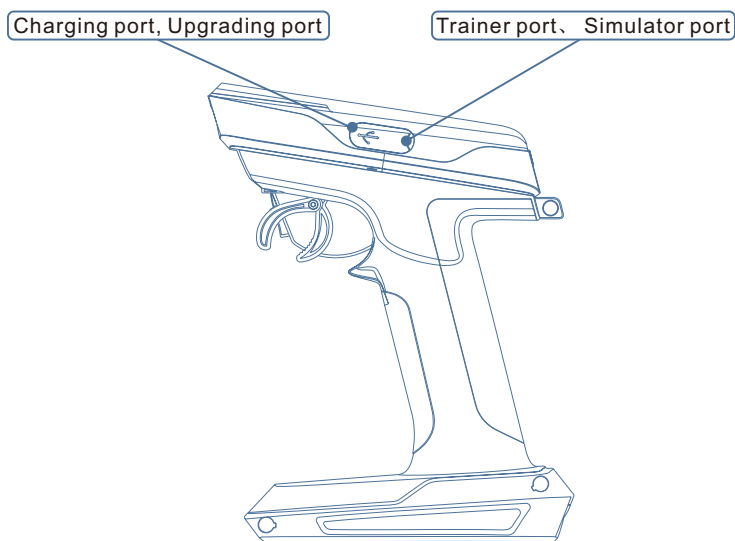

PS1 Button Ps1
 Default: timer (start/pause)
 PS2 Button Ps2
 Default: User Menu

Power on and off

Power on: Press and hold the power button for 3 seconds

Power off: Press and hold the power button for 3 seconds

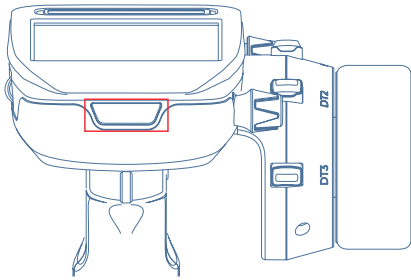

Description of the home screen:

Tip: Users can set the content displayed on the main interface according to actual needs. Please refer to page 97, the following diagram is the factory default setting description

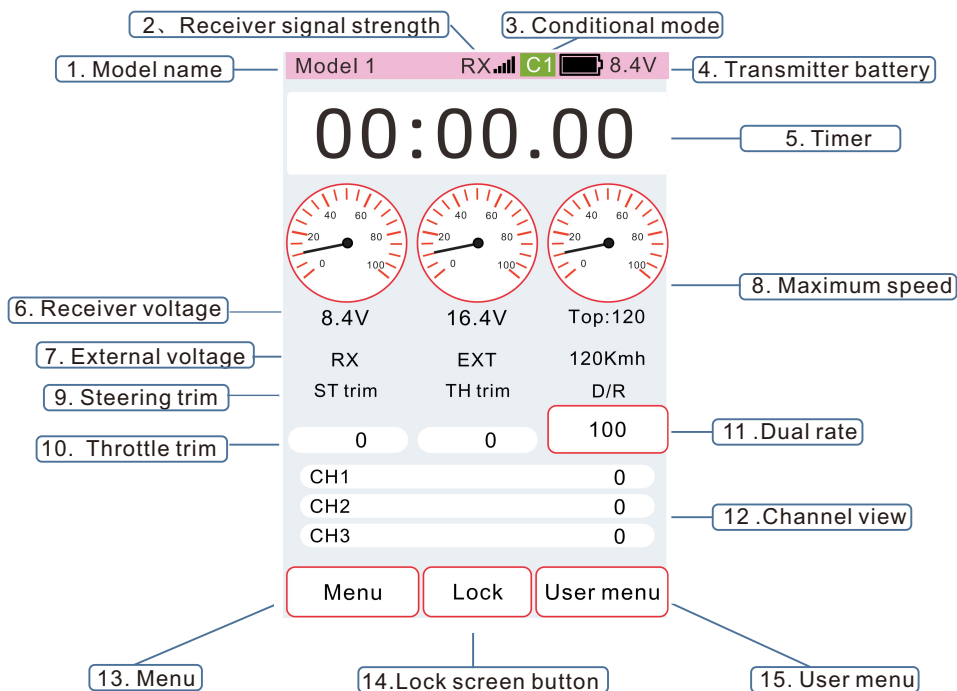

► Long time no operation alarm, automatic shutdown function (please refer to page 96 for detailed functions) If there is no operation on the wheel, trigger, button switch or touch screen, etc., 100 seconds before the set time, the screen will display: [Reminder: The system will shut down after 100 seconds if it has not been operated for a long time], and a voice reminder will be issued. At this time, as long as the wheel, trigger, etc. are operated, the automatic shutdown function is released. If the wheel, trigger, etc. are not operated,

► the system will automatically shut down after 100 seconds.

Screen Reminder: Reminder: If you do not operate for a long time, the system will shut down after 100 seconds

► Voice broadcast: automatic shutdown after 100 seconds

Low voltage warning (see page 85 for details)

When the battery voltage of the transmitter drops to the usable limit, the transmitter will issue a voice announcement: Transmitter voltage is low: **V (current voltage).

X9S supports 2S lithium battery power supply and 3.7V 18650 battery power supply. The low voltage alarms for these two batteries are different. When changing the type of battery used. Be sure to change the type of battery used by the transmitter according to 【Low battery setting (page 85)].

Note that when a low battery alarm occurs, please retract the car (boat) immediately and stop the control (flight) During the rack control (flight), once the battery is exhausted, the car (boat) will be in danger of losing control

⚠ Attention

When the transmitter is reminded of low battery, please take back the model of the car, boat, etc. immediately, and stop the control.

When the model is operated, once the battery is exhausted, the car, boat, etc. will be in danger of getting out of control.

Steering and throttle operation (Operation Instructions for Ordinary Model Cars)

Channel 1: Direction wheel, the wheel turns left and right, and the operation model turns.
Channel 2: Throttle trigger, the trigger is controlled forward and backward, and the operation model moves forward, backward, stops, and brakes.

Throttle trigger operation

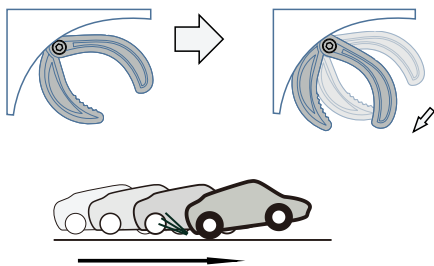

Pull the throttle trigger forward, and the model is in a forward state.

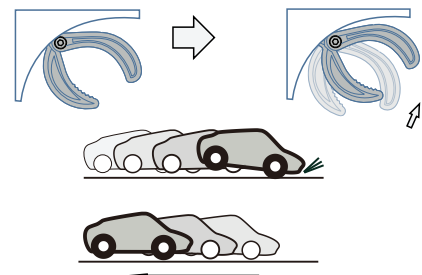

When the throttle trigger is pressed back, the model is in the braking or reverse state

Operation of the steering wheel

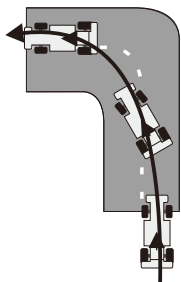

When the direction wheel turns left, the model turns left

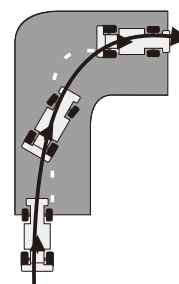

When the direction wheel goes right, the model turns right.

How to operate the digital trim

When the mechanical structure adjustment of the model is completed and the runner is at the midpoint, the model still deviates to the left or right while driving, and the direction can be trimmed to go straight ahead. When the trigger is at the midpoint, adjust the trim so that when the trigger is released, the model remains stopped and not on the brakes.

Dual rate (direction)

The servo output ratio of the direction channel can be adjusted.

Brake rate

The brake function of the accelerator channel and the output ratio of reverse can be adjusted

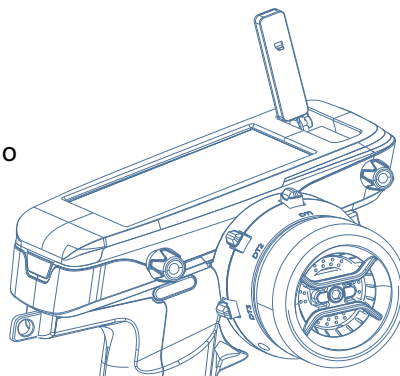

How to operate the digital trim

Default setting:

DT1: direction trim,

DT2: throttle trim,

DT3: Dual Rate (Direction)DL: Brake rate

Press or rotate the trim key left or right to operate the trim value +/-, and you can view the trim value on the screen.

1. Direction trim DT1 trim display
2. Throttle trim DT2trim display
3. Dual rate (direction) DL indication

Voice broadcast content

Trim Min: Minimum trimTrim

Midpoint: Midpoint trim

Trim Max: Maximum trim

Tip: There are voice reminders for trim at the minimum, mid-point, and maximum times. The volume of the reminder can be set in [System menu] - [Sound and Vibration] - [Trim]

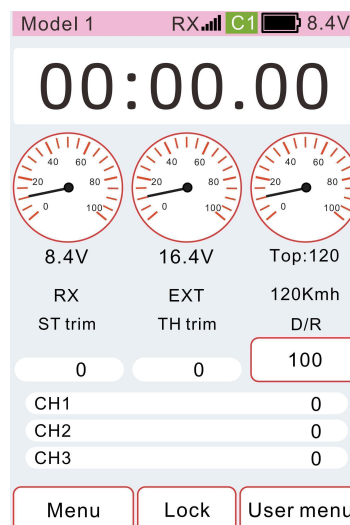

On the right interface, you can view the Trim value:

- ① **【Base setting】** - **【Sub trim】** interface, you can view theTrim value
- ②[Menu]-[Base setting]-[Trim setting] interface can check the fine adjustment value

When the Trim keys are set to different functions, the displayed range and voice announcement are different.

- ① **【Dual rate】** - **【Steering】** Channel display: 0~100
- ② **【Brake rate】** display: 0~100
- ③ **【Curve】** - **【EXP】** Display: 0~100Voice

Broadcast content

Min. trim: Minimum trim

Max.trim:Maximum trim

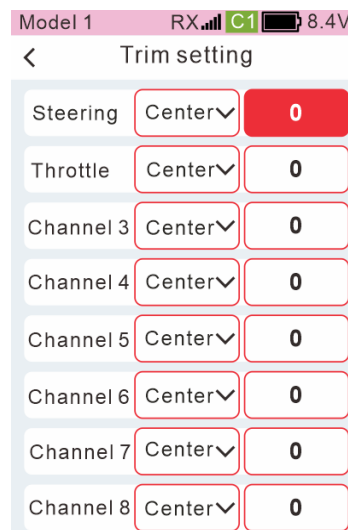

Trim settings lock and unlock

Set the corresponding trim setting key lock in [System menu] - Touch and trim lock].

By setting, the operation of digital trim DT1, DT2, DT3, DL and other physical keys can be prohibited.

Lock screen: long press the [Lock] key to lock the trim function.

Unlock: Press and hold the [Unlock] key to lock the trim function.

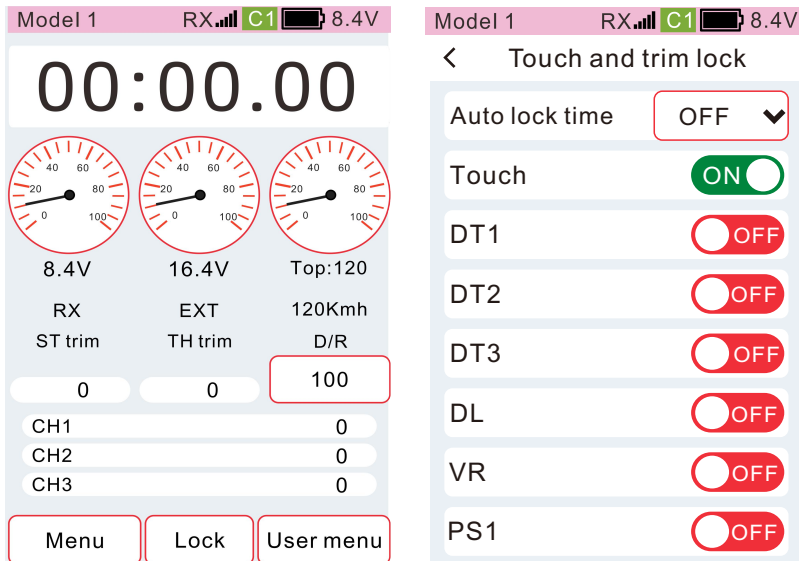

How to adjust the trigger position

The screw shown in the figure can adjust the position of the trigger before and after by adjusting.

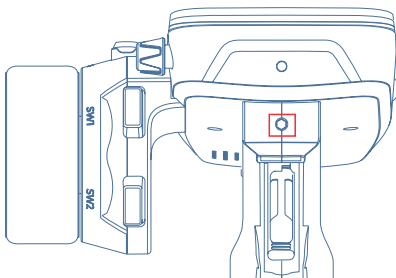

Adjustment method: Use a 2.5mm Allen screwdriver to adjust the screw as shown in the figure clockwise or counterclockwise to adjust the position of the trigger fore and aft.

Clockwise rotation: the further away from the grip.

Counterclockwise rotation: the closer to the grip.

Method for adjusting: the size of trigger opening

Through adjustment, you can adjust the trigger opening size according to personal habits.

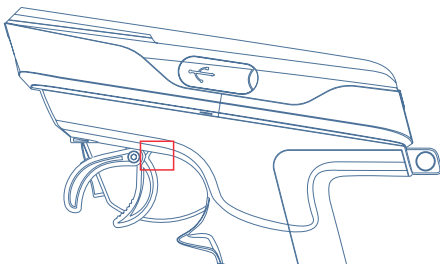

Method of adjustment:

Use a 1.5 mm hex socket screwdriver to loosen the screws counterclockwise, depending on personal use. Okay, adjust the trigger opening. Then tighten the screw clockwise to make the trigger open Fixed.

Note: After adjusting the trigger opening, you need to re-calibrate the trigger through [System menu] - [Calibration] - [Trigger].

Wheel Angle adjustment

1. Press the wheel with your hand, and at the same time use a 2.5mm Allen key to remove the fixing screw of the wheel.
2. Pull out the runner and pull out the runner adapter.
3. Install the included Kimi screw, and adjust the length of the Kimi screw according to personal usage habits.
4. Using a 2.5mm hexagonal wrench, install the runner connector first, then install the runner, and finally screw in the fixing screws according to the method of restoring to the original state.

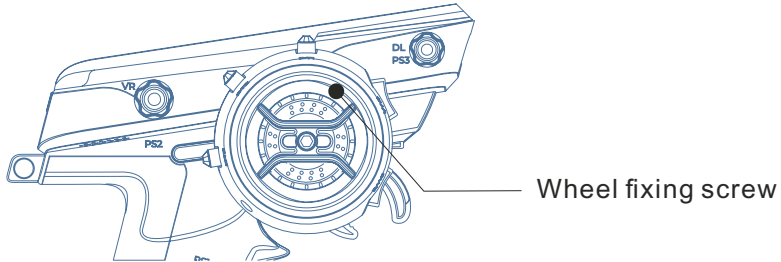

Note: After adjusting the angle of the steering wheel, you need to re-calibrate the wheel through [[System menu] - [Calibration] - [Steering]].

Charging function

This product has built-in charging function for 7.4V lithium battery or two 18650 batteries, the nominal battery voltage is 7.4V, the battery can be charged to 8.4V, and other types of batteries cannot be charged.

Tip: Type-C data cable and charging head need to be purchased separately.

Indicator status

Red light on: charging

Red light off: fully charged

Warning: When charging, avoid unattended charging, and keep the charging area away from objects such as combustible materials. The company does not assume any responsibility for all consequences caused during the charging process.

Charging operation steps:

1. Connect the power adapter to the Type-C data cable and connect it to the charging port of the transmitter.
2. When the transmitter is turned off, confirm that the charging indicator light is red.
3. After the charging is completed, the charging indicator will turn off.
4. After charging, please remove the plug and unplug the charger from the socket.

How to replace the battery

When the transmitter will not be used for a long time, the battery should be removed and kept in a safe place!

Supported battery types: ①2S 7.4V lithium battery ②2AA 18650 battery (can be charged by transmitter)

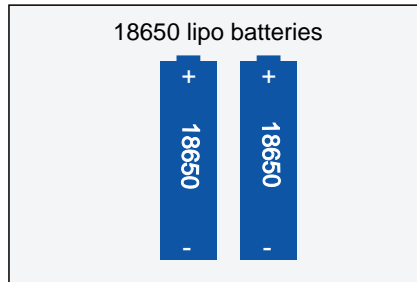
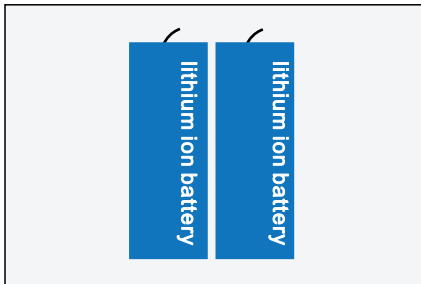

Battery replacement

- 1: Press and hold the position on the battery cover of the transmitter and slide it in the direction of the arrow
- 2: Remove the battery and remove the battery connector
- 3: Insert the battery connector first, and then into the battery compartment
- 4: Install the battery cover to complete the installation

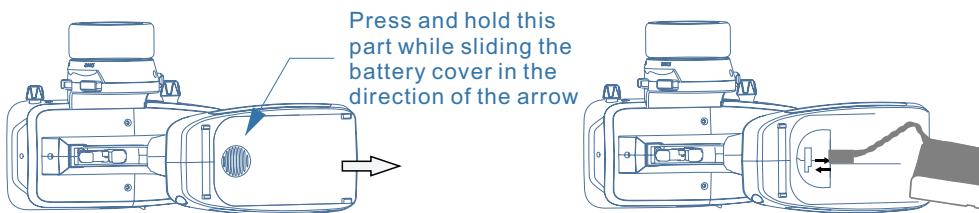

Note: When closing the battery cover, take care to avoid the battery wires being pinched by the battery cover. If it is caught and short-circuited, it may cause burns or fire due to abnormal heat.

How to adjust the tension of the trigger/wheel

How to adjust the tightness of the wheel spring

Adjust the spring strength of the wheel to change the tightness of the wheel.

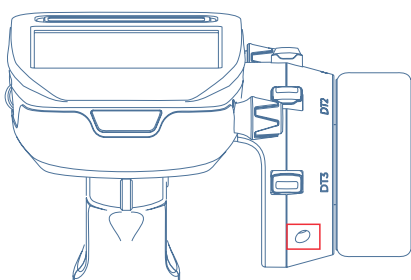

Adjustment method:

Adjust the spring strength of the wheel by adjusting the screw clockwise or counterclockwise using a 1.5mm Allen screwdriver. Clockwise rotation: the stronger the elasticity. Rotate counterclockwise: the less elastic.

Note: When over-turned counterclockwise, the screw will come off.

How to adjust the tension of the trigger spring

Adjust the spring strength of the trigger to change the tightness of the trigger.

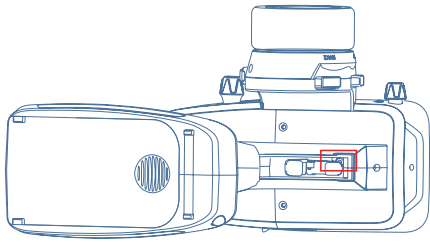

Method of adjustment:

Adjust the illustrated screws clockwise or counterclockwise using a 1.5 mm inner hexagon screwdriver, Adjust the spring strength of the runner.

Clockwise rotation: The stronger the elasticity.

Counterclockwise rotation: the weaker the elasticity.

When over-turned counterclockwise, the screw will come off.

How to operate a transmitter antenna

How to operate a transmitter antenna

Rotation angle of the antenna

When the antenna angle is at 45° or 90° , the control distance may be increased due to the vertical state (varies due to differences in communication conditions)

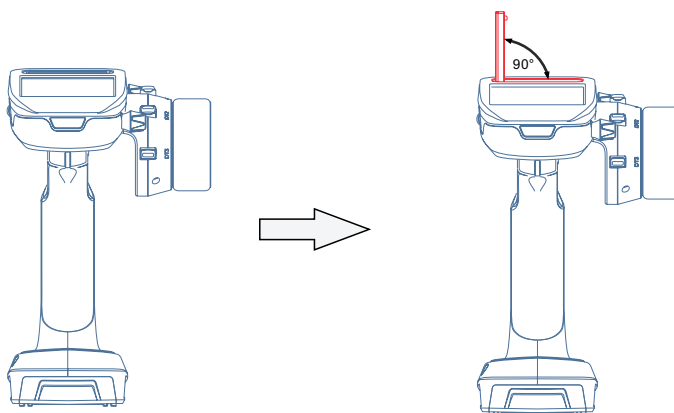

Note: When manipulating the model, do not block or hold the antenna with your hands, otherwise the signal output will be weakened, resulting in shortened receiving distance and danger

The antenna can only be rotated within the angle range shown in the above figure. Do not exceed this angle range or forcefully move it to cause damage. The internal cable may break or cause malfunction, which will greatly shorten the receiving distance and increase the danger.

How to connect receiver and servo

Please connect the receiver and servo as shown in the figure below. The method of connecting the motor and battery from the electronic governor varies depending on the type of electronic governor used.

When using electronic governor

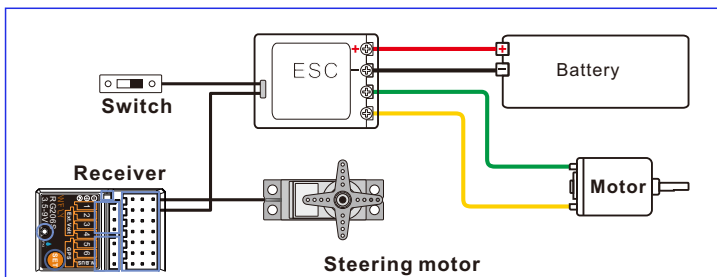

Gas powered model

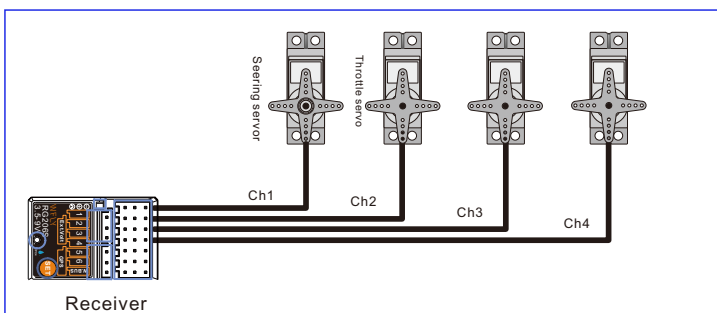

Safety precautions during installation

Receiver antenna

- Antenna cannot be broken or bundled
- Do not bundle the wires of the antenna, the steering gear and the electronic governor together
- Do not approach places with high current such as electronic governors and batteries.
- Do not cover the surface of the receiver with other conductive materials such as metal and carbon fiber, and do not use metal materials such as metal as the antenna bracket.
- Install the antenna bracket as close to the receiver body as possible.

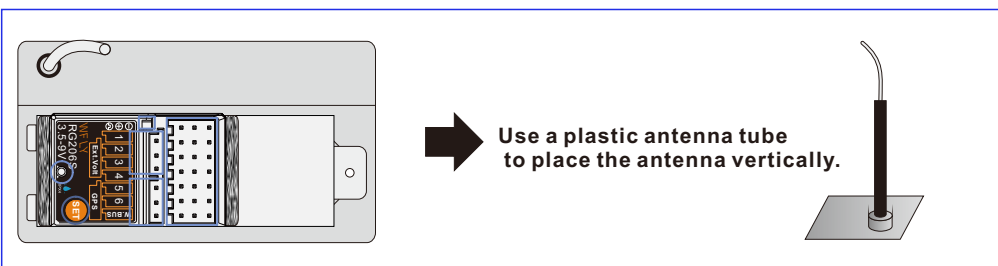

Shock resistance of the receiver

Please wrap the receiver with sponge rubber, or fix it with thicker (more than 3 mm) double-sided tape to achieve shock absorption.

Electronic governor plug, steering servo cable and other plug connections

When connecting the accessories of the steering servo, battery, and electronic governor, please confirm that they are installed in place to prevent them from falling off due to the vibration of the model, which may cause damage.

Servo travel confirmation

Please try to output the servo output of each channel to the action limit, and adjust the stroke so that the connecting rod will not be stuck or bent. If the output of the servo is over-travel, it may cause damage to the servo, or damage to the mechanical structure, and the danger of violent shock.

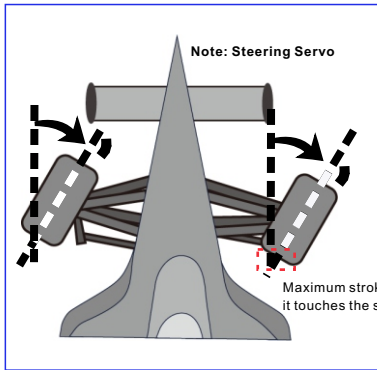

Adjust the stroke of the steering servo so that the steering servo connecting rod will not be squeezed when the vehicle body is at the maximum angle.

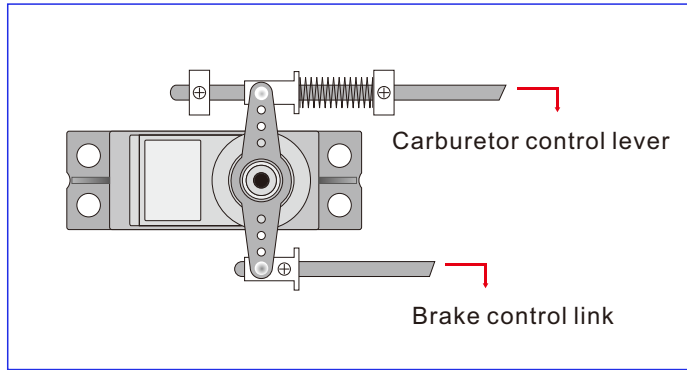

Adjust the throttle servo travel amount so that the servo rod will not be squeezed when the carburetor of the engine is fully opened, fully closed and braked.

Electronic governor

When installing the heat sink, do not come into contact with materials that are easily conductive, such as aluminum or carbon alloy chassis.

Brush motor interference countermeasures

When using a brush motor, be sure to install a noise-canceling capacitor.

If the filter capacitor is not installed or the capacitor connection is incorrect, the receiver, etc. may be affected by the electromagnetic interference generated by the motor, resulting in incorrect operation. So be sure to solder three filter capacitors on the motor.

Also, if using an ESC with a Schottky diode, please solder the negative (cathode) to the positive (+) end and the other end to the negative (-) end.

When welding, the positive and negative poles of the motor must be consistent with the actual input power line, otherwise the ESC or diode will be damaged.

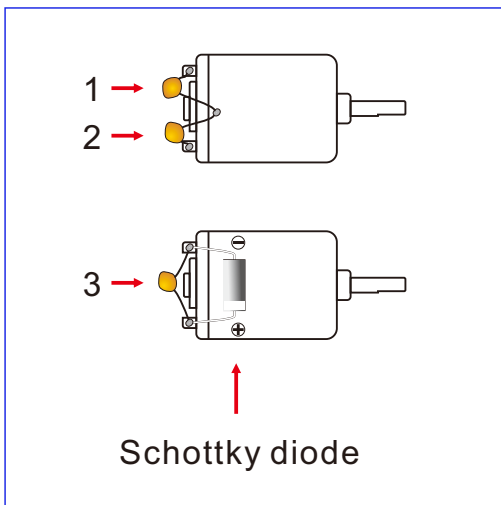

Other interference countermeasures

When installing the parts in the car body, do not let the metal parts come into contact with the vibration of the car body.

Setup sequence for the model

Preparation before transmitter setup

Before setting various functions of the transmitter, please confirm and set the following ①~④ items.

After turning on the power, the currently selected model number will be displayed on the main interface.

If you need to change it, please use the model selection function

1: RF signal output confirmation

Method: [Menu]-[System menu]-[Trainer and simulator]

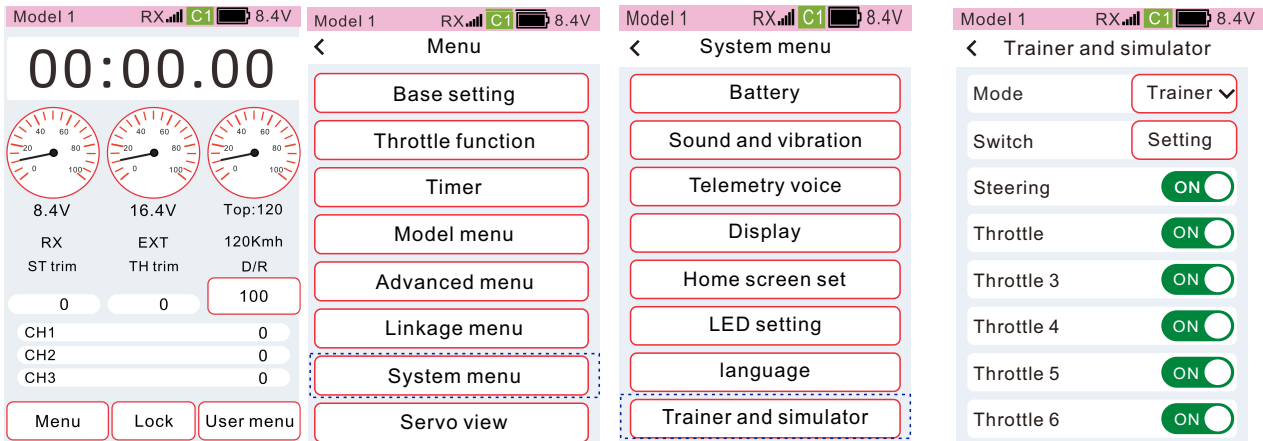

2. Confirmation of servo type

Method: [Menu]-[Linkage menu]-[Servo type]

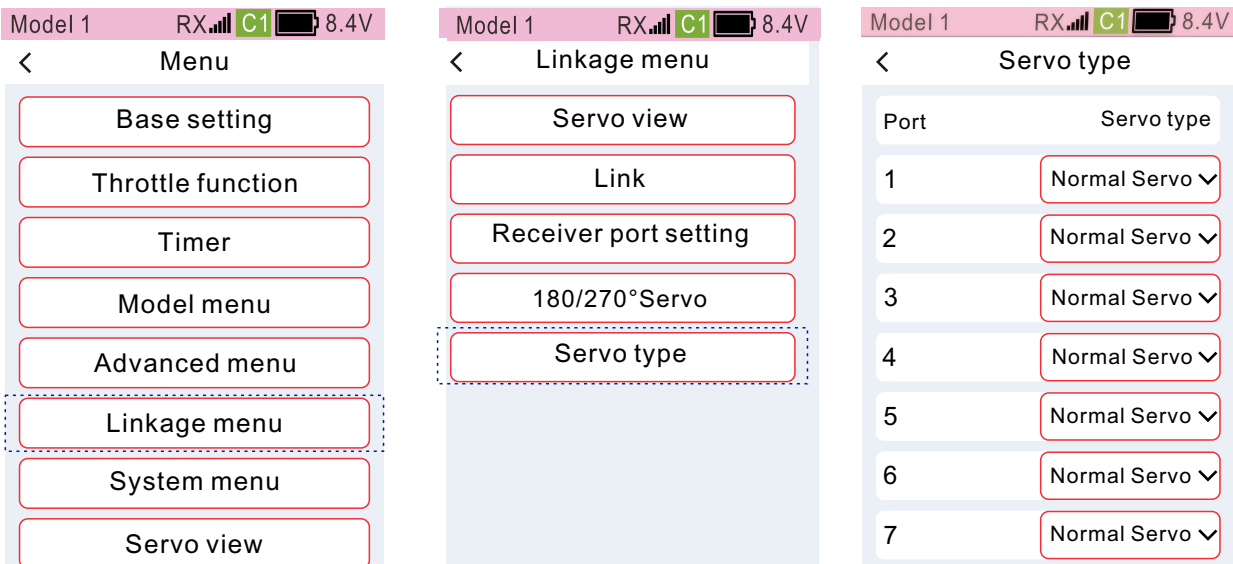

When set to [Digital], please use digital servo.

When set to [Normal], please use an normal servo/digital servo.

When set to [Digital], please use the digital servo, pay attention (the normal servo will burn)

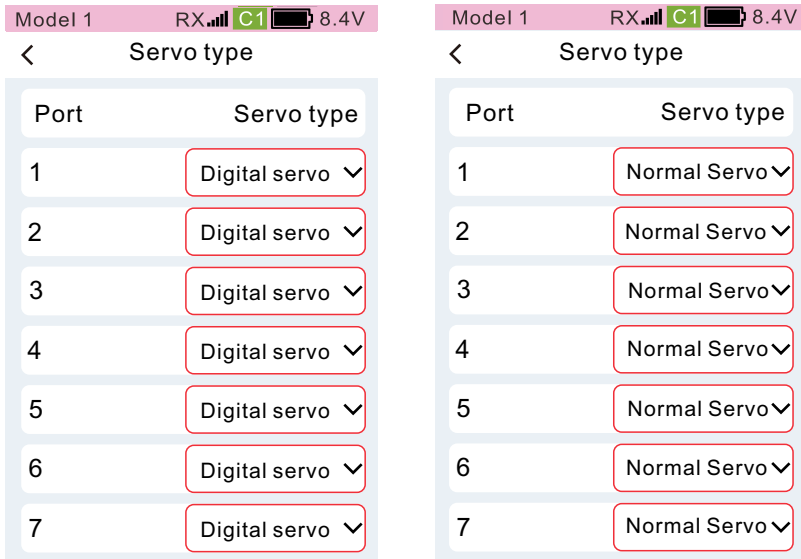

3. Accelerator mode confirmation

Method: [Menu]-[Throttle function]-[Throttle mode]

According to the accelerator trigger, set the accelerator forward and brake action [Mode] to [Forward 50: Brake 50], [Forward 70: Brake 30], [Forward 100: Brake 0]. For details, please refer to **【Throttle Mode】** (page 46).

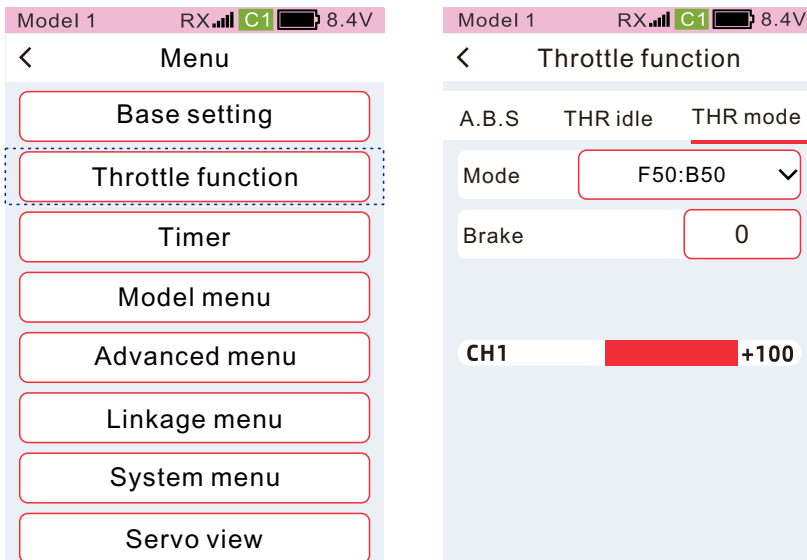

4. Initial setting of trim

Method: **【Menu】** - **【Advanced menu】** - **【Channel setting】**

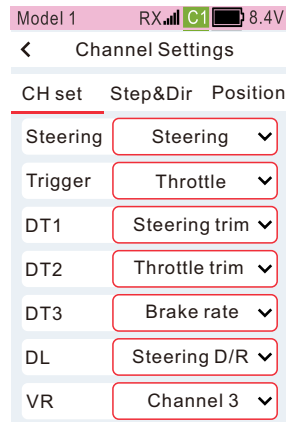
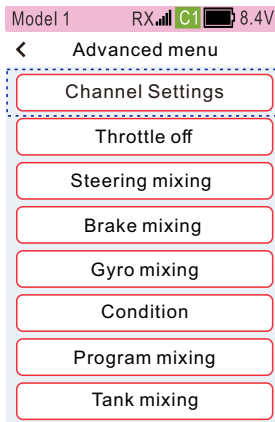
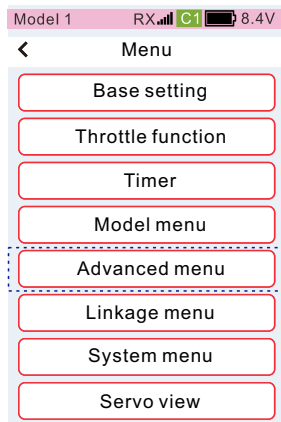
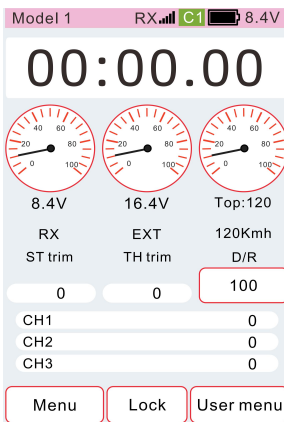

Check Trim 1 (Dt1)

By default, the Trim 1 function is a directional trim.

Toggle the nudge to confirm the corresponding movement of the directional nudge on the bar.

Check Trim 2 (Dt2)

By default, the trim 2 function is throttle trim.

Toggle the trim to confirm that the throttle trim moves accordingly on the bar.

Check Trim 3 (Dt3)

By default, the trim 3 function is the brake ratio.

Toggle the trim adjustment to confirm the corresponding change of the ratio value of the brake ratio in [Menu]-[Base setting]-[Dual rate]-[Throttle channel]-[Brake].

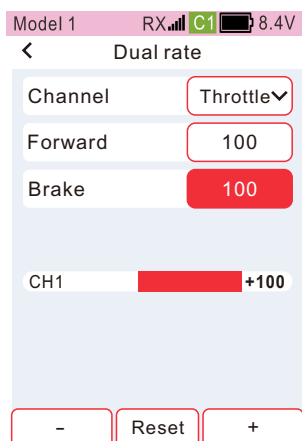
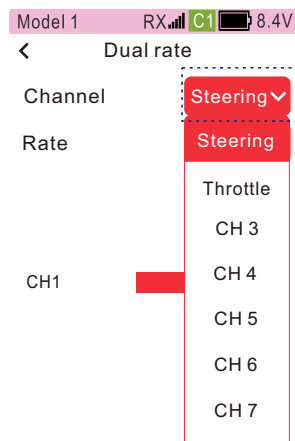
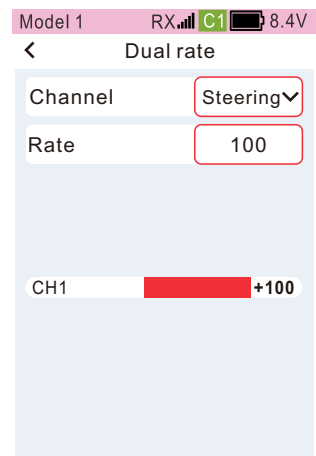
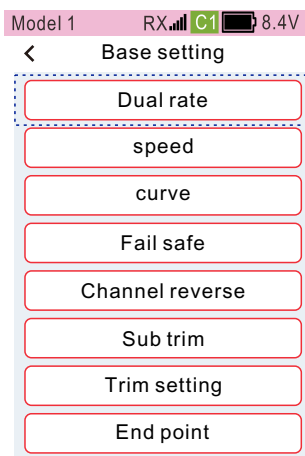
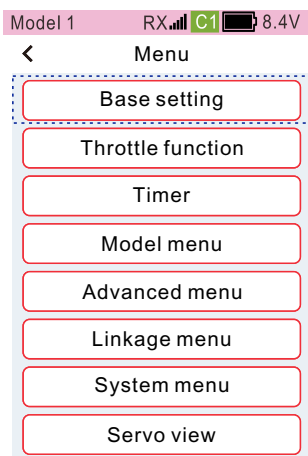
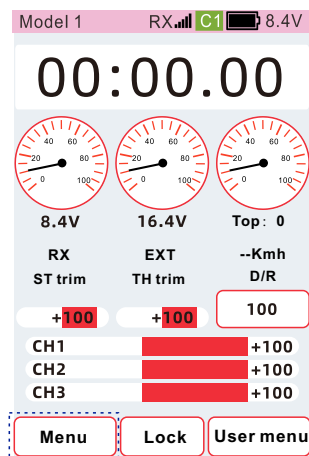

Check trim Tsetting 4(DL)

By default, the DL function is dual rate-direction.

Twist the knob to confirm that the dual rate-direction value changes accordingly.

When installing the steering gear in a model car, it is recommended to perform the function Settings in the following order.

1. Perform steps 1-4 above (Initial trim settings).
2. Set the direction of the servo and motor in [Channel reverse].The direction of movement of the servo may need to be set to be reversed relative to the direction of operation of the transmitter. Before installing the servo, please check the operating direction of the servo, and make corresponding settings in [Channel reverse]

Method: [Menu]-[Basic setting]-[Channel reverse]

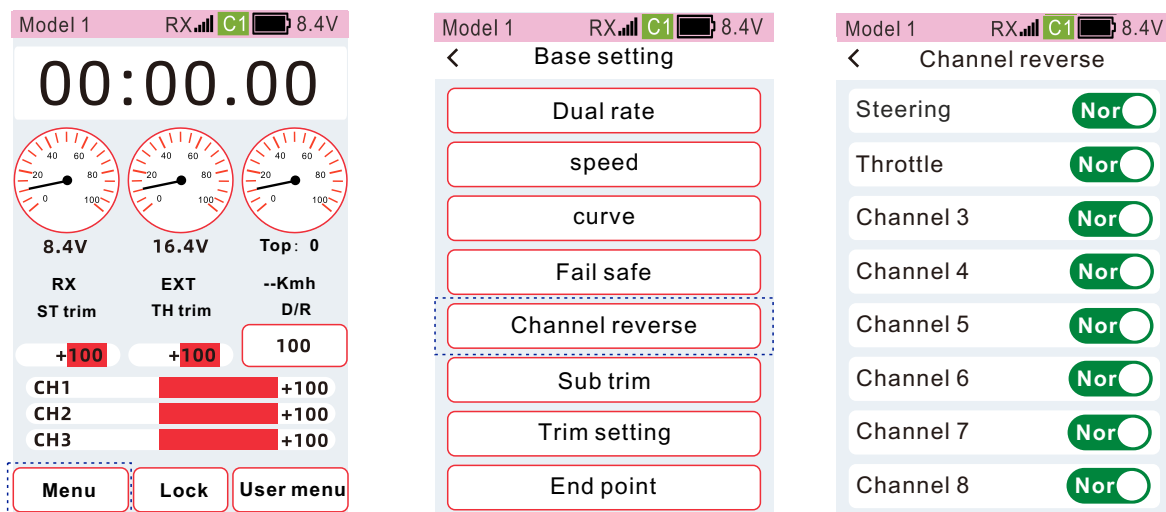

3. Adjust the neutral point of the servo.

Method: [Menu]-[Base setting]-[Sub trim]

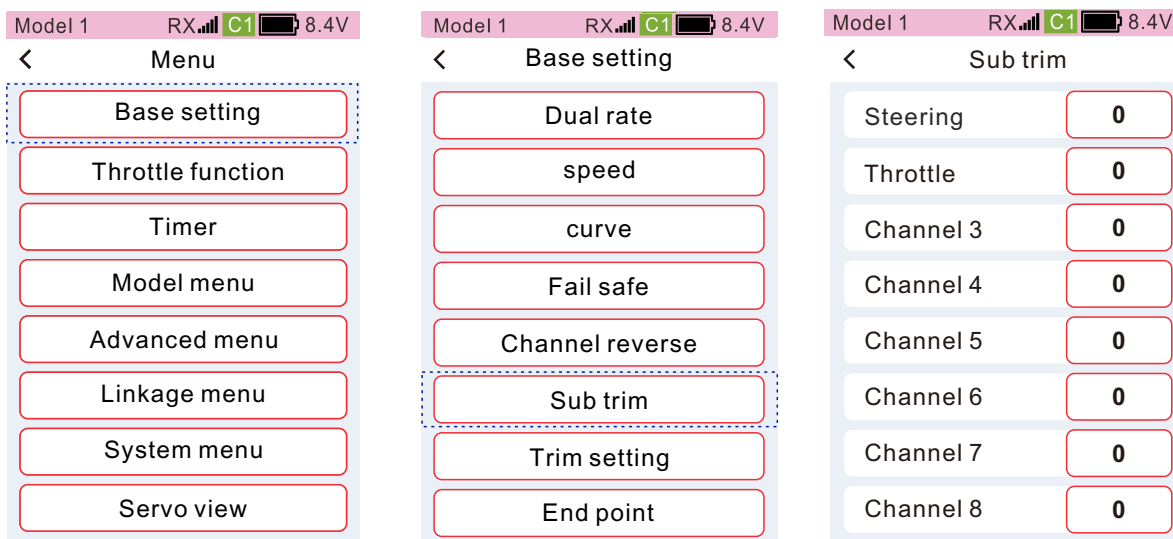

4. Set the throttle/mechanical brake stroke according to your own preferences and habits. When the stroke is adjusted, make corresponding compensation in the [Calibration] menu. For details, see page 102

5. Set the maximum stroke of each channel.

Method: [Menu]-[Base Setting]-[End point]-[End point]

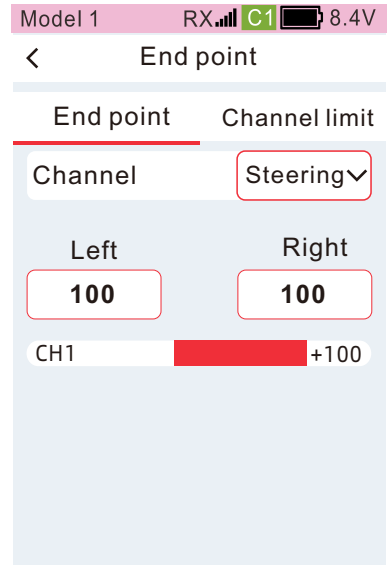
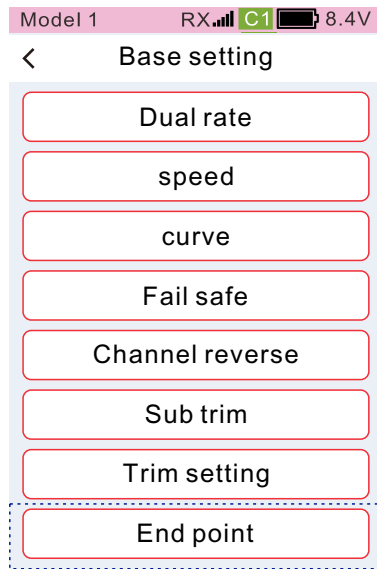
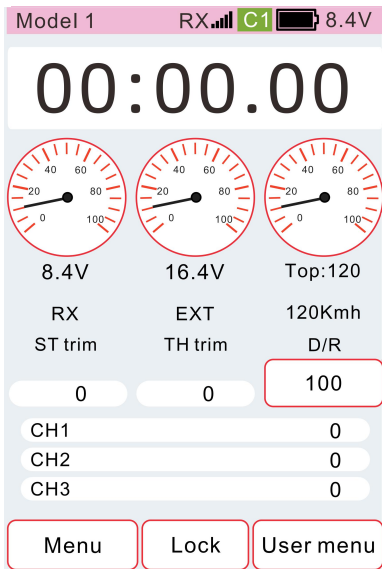

6. Set up Fail safe

Method: 【 Menu 】 - 【 Base setting 】 - 【 Fail safe 】

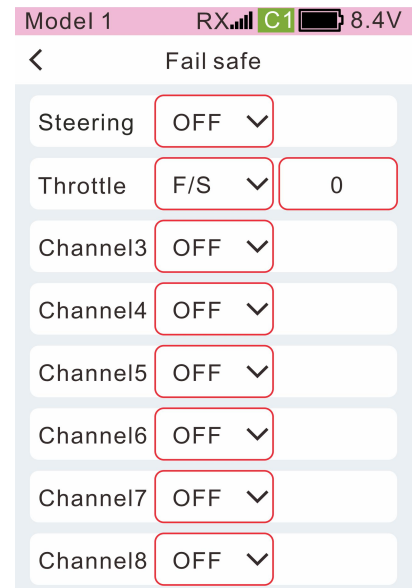
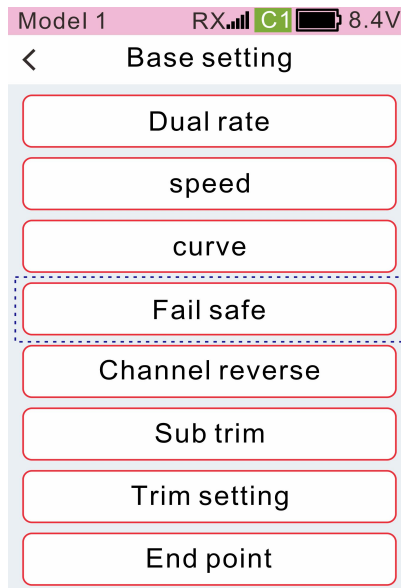
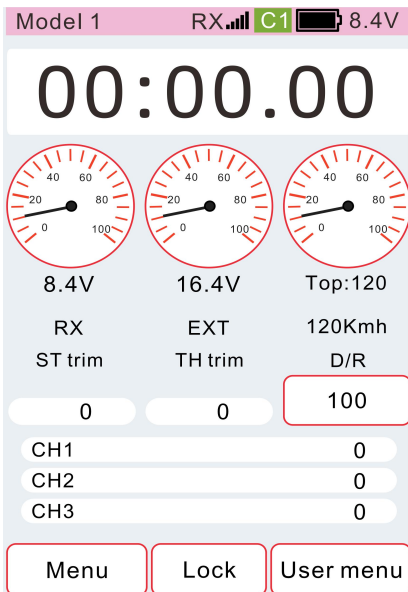

Product feature

Full color LCD capacitive touch screen3.5-inch full-color LCD capacitive touch screen, providing a simple and convenient interactive interface

Telemetry

Real-time display of receiver, power battery voltage, model speed and other information to clearly understand the status of key parameters of the model

Gyro

External gyroscope, built-in gyroscope function, wireless settings, improve the maneuverability of the model

User menu

Customize the user menu function list, which can be edited as frequently used functions and quickly recalled for use

Customize the main interface

According to the characteristics of the model, the user can edit the display function, status, picture and other information required by the main interface

Multiple themes

Provide up to 7 color schemes for users to choose from

Indicator light

Directional indicators with multiple dynamic effects and mood indicators with multiple color settings

Full channel function

Dual rate, speed, curve and other functions support full channel settings

Voice broadcast function

Low battery, low signal, telemetry broadcast, trimming, timer, engine shutdown, throttle idle, condition mode and other functions support voice broadcast

User backup data function

Back up user model data, model data is not afraid of being modified and cleared.

Base setting

Dual rate

This function can adjust the direction, throttle, channel 3 to channel 9, all channels are dual rate, dual rate (direction), brake rate can be set to DT1, DT2, DT3, VR, DL for linkage control. (Dual Rate (Direction): The default setting is DL Linkage Control.

Braking rate: The braking rate of the throttle channel can be adjusted. (Brake rate: The default setting is DT3 linkage control)

Throttle channel: forward rate and braking rate can be adjusted individually.

Default: 100%

Setting range: 0%~100%

Tip: When [Advanced menu]-[Condition]-[Dual rate] is set to ON, Condition 1 and Condition 2 dual ratio can be set independently.

Setting method of dual rate: Function path: [Menu] - [Base setting] - [Dual Rate]

- Click the channel Settings item and select the desired channel from the drop-down list

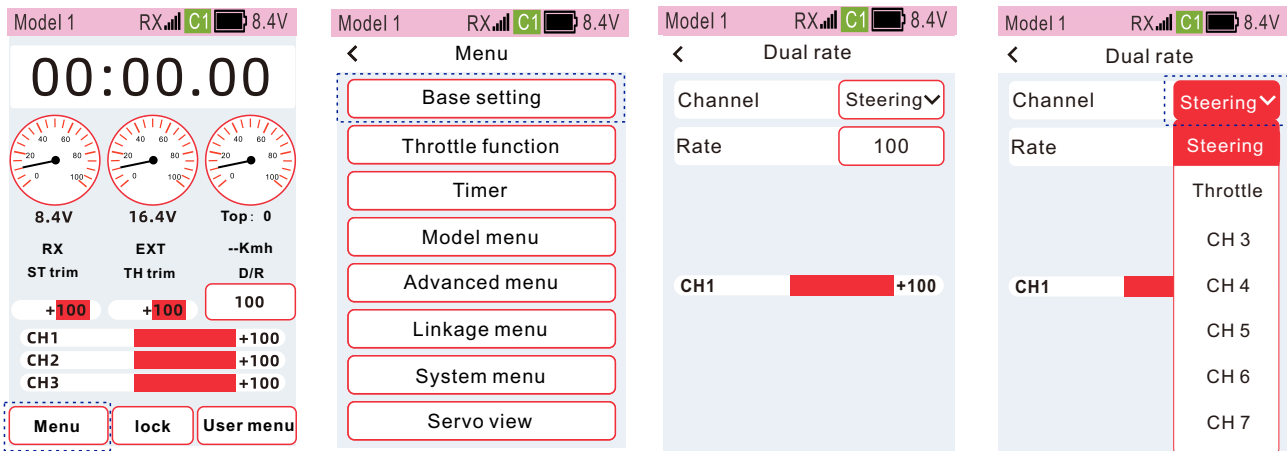

- Direction, throttle, channel 3 to channel 9 ratio Settings

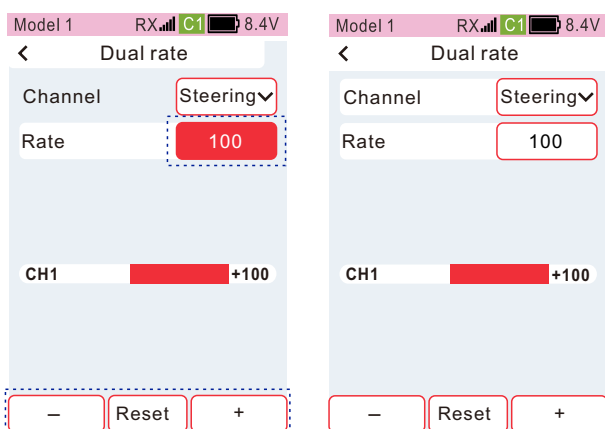

- ① Click "Rate", set the focus value to display as the theme color (the default theme is red), the bottom of the screen shows [-] [reset] [+].
- ② Click or long press [-] [+] to adjust the ratio.
- ③ After setting, click the title bar to return to the upper-level menu

How to set the brake ratio

- Channel selection, the channel is set to [Throttle].
- Click [Brake] rate, the setting value will be displayed as the theme color, and [-][Reset][+] will be displayed at the bottom of the screen.
- Click or long press **[-]** **[+]** to adjust the ratio.
- After the setting is completed, click the title bar to return to the previous menu .

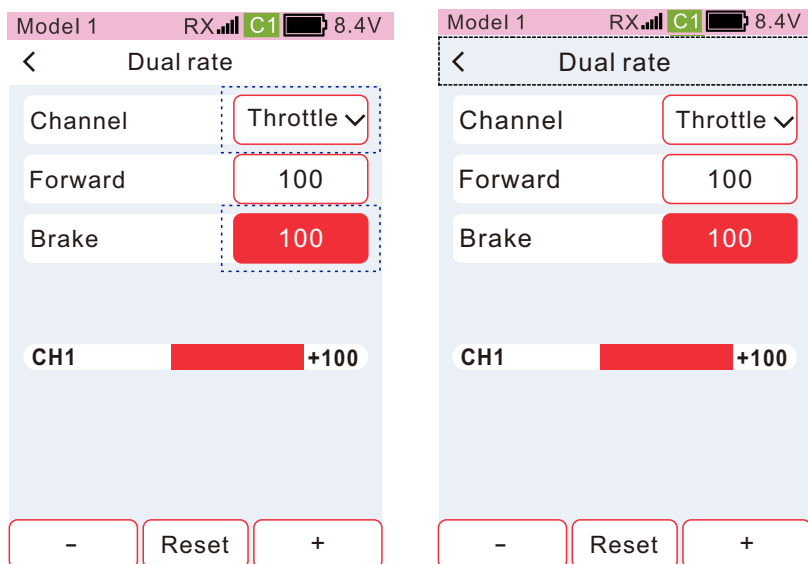

Speed

This function is used to control steering and throttle, and the servo speed of channel 3~channel 9.

For the directional channel, when rapidly manipulating the direction, momentary understeer, stall or wheel spin may result. Adjustable directional speed function for smooth turns.

For the throttle channel, when the trigger is suddenly operated on a slippery road, it may cause the wheels to slip and not accelerate smoothly. Smooth handling and power savings are achieved by adjusting the throttle speed function.

Default value: 0%

Setting range: 0%~100%

Tip: When [Advanced menu]-[Condition]-[Speed] is set to ON, the speed of condition 1 and condition 2 can be set separately.

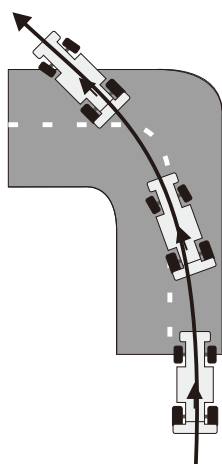

Understeer

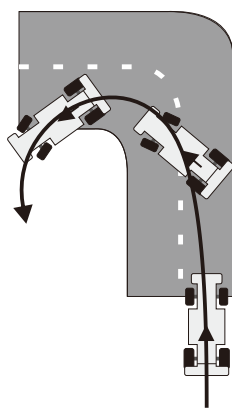

wheel slip

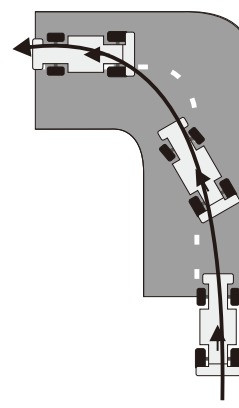

Smooth turn

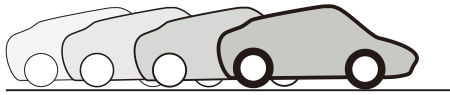

Set the throttle speed function, can smooth and fast start

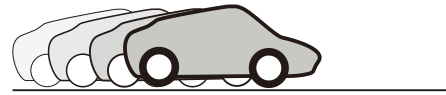

If the throttle speed function is not set, the wheel slips, and it is impossible to start smoothly and quickly

How to set the direction speed

It is applied to the output delay when operating the servo gear. The speed of the steering wheel (Turn) and (Return) can be set separately. When the steering speed is slower than the set speed, the steering output has no delay effect.

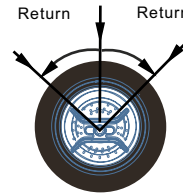
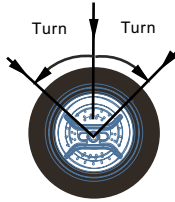

Function path: [Menu]-[Base setting]-[Speed]

Model 1 RX C1 8.4V

00:00.00

8.4V 16.4V Top: 0

RX EXT --Kmh

ST trim TH trim D/R

+100 +100 100

CH1 +100

CH2 +100

CH3 +100

Menu Lock User menu

Model 1 RX C1 8.4V

< Menu

Base setting

Throttle function

Timer

Model menu

Advanced menu

Linkage menu

System menu

Servo view

Model 1 RX C1 8.4V

< Speed

Channel Steering

Turn 100

Return 100

CH1 +100

- Channel selection
- Direction speed setting

Model 1 RX C1 8.4V

< Speed

Channel Steering

Turn Steering

Return Throttle

Channel 3

Channel 4

Channel 5

Channel 6

Channel 7

CH1 +100

Model 1 RX C1 8.4V

< Speed

Channel Steering

Turn 100

Return 100

CH1 +100

- Reset +

①Click **【Turn】** or **【Return】** ratio, the setting value is focused and displayed as the theme color (the default theme is red), and **【-】** **【Reset】** **【+】** is displayed at the bottom of the screen.

②Click or long press **【-】** **【+】** to adjust the ratio.

How to set the throttle speed

When applied to rapid acceleration, the output of the throttle servo or electronic governor has a delay effect. The speed of trigger operation forward (Turn) and release (Return) can be set independently. When the speed of operating the accelerator is slower than the set speed, or when operating the brake, the accelerator output has no delay effect.

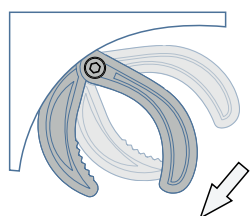

Trigger forward

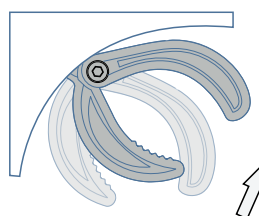

Trigger return

Throttle speed setting

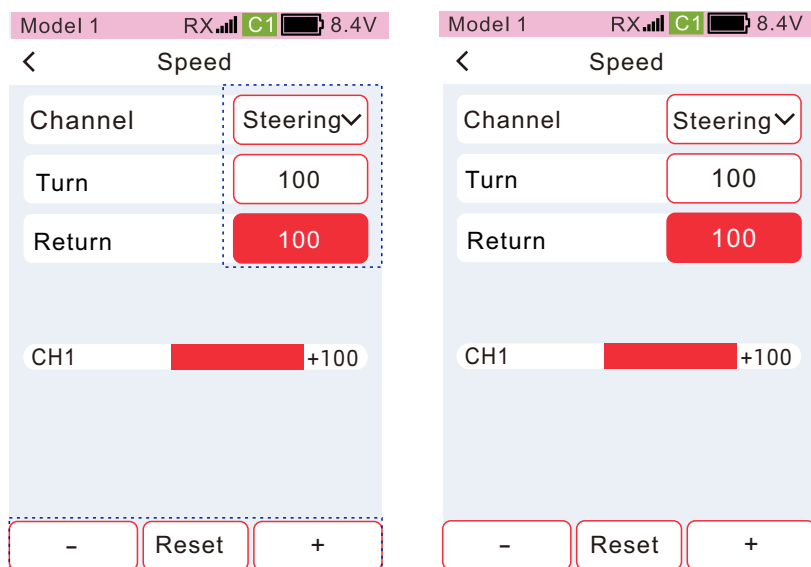

①Click **【Turn】** or **【Return】** ratio, the set value is focused and displayed as the theme color (the default theme is red), and the bottom of the screen displays **【-】** **【Reset】** **【+】** .

②Click or long press **【-】** **【+】** to adjust the ratio.

③ After the setting is completed, click the title bar to return to the previous menu.

Curve

This function is used to adjust the direction, throttle, channel 3 to channel 9 curve, so that the action on both sides of the neutral point of the servo becomes sensitive or smooth. In addition, when the curve type is EXPonential, it supports mapping to the curve function through DT1, DT2, DT3, VR, DL (setting path: [Menu] - [Advanced menu] - [Channel setting] - [CH set], you can use the physical Press the key to directly adjust the EXPonential rate. The curve supports three types: EXP, Point and VTR.

Function path: [Menu]-[Base setting]-[Curve]

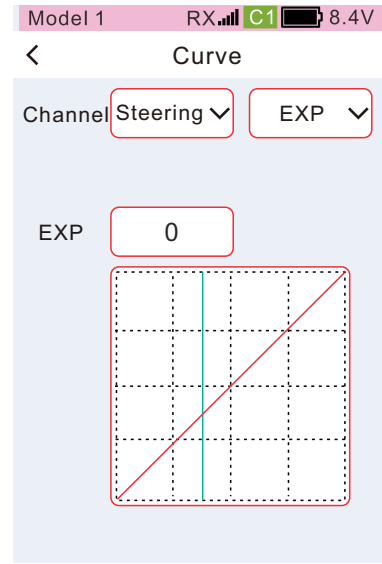
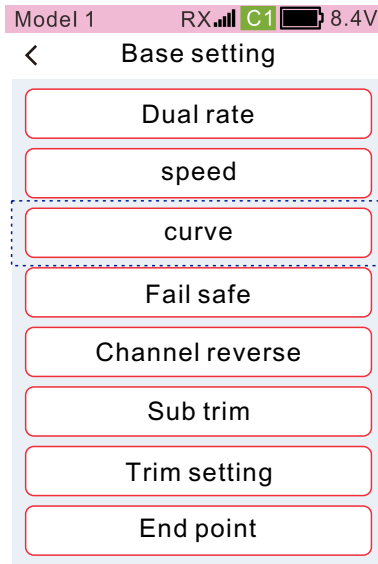
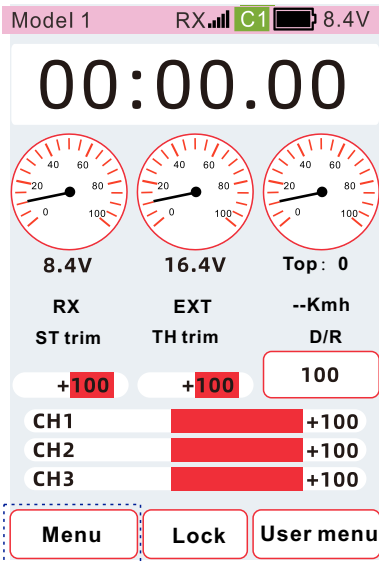

1. Select the channel to be set
2. Exponential curves (steering and other channels)
3. Select the curve type

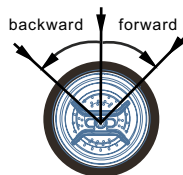
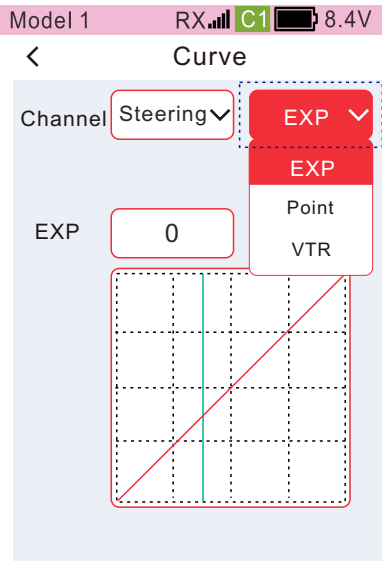
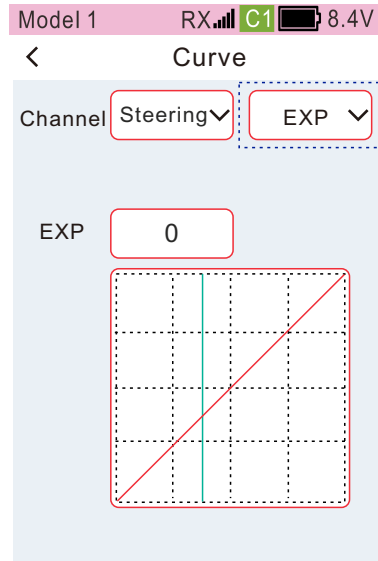
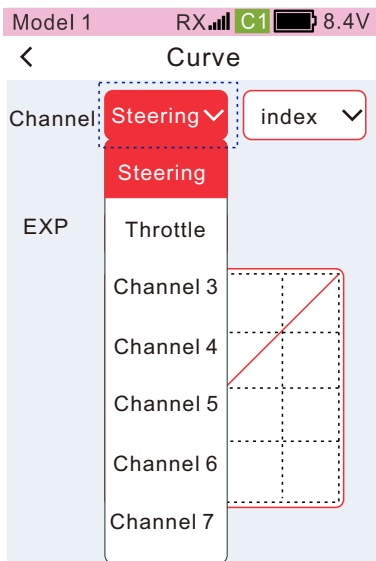

Wheel operation

4. The index is -1% to -100%

5. VTR (direction and other channels)

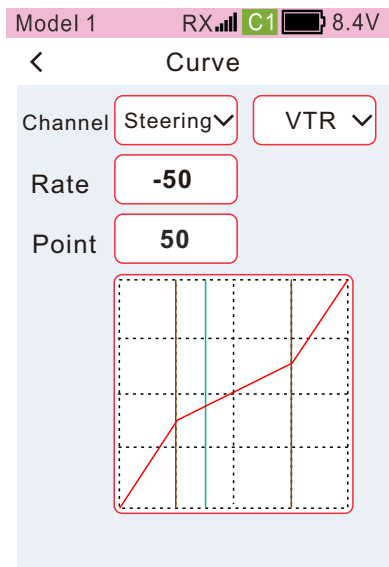
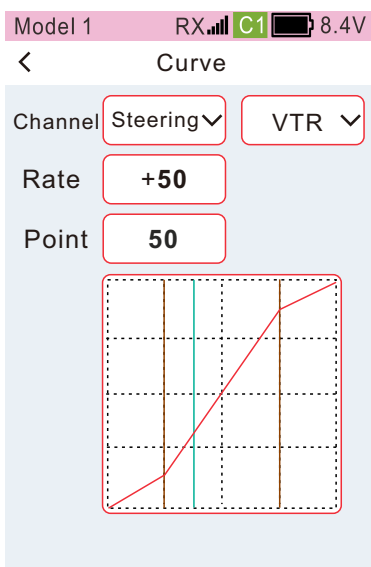
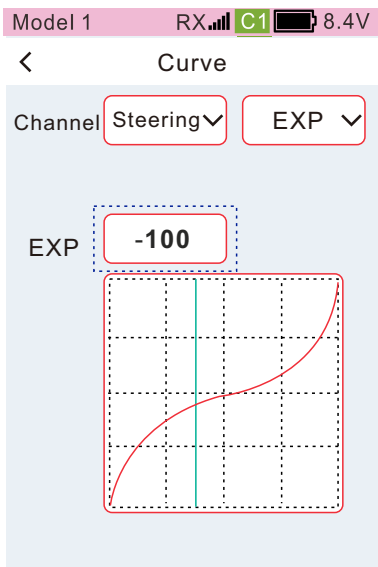

The ratio is +1 to +100

The ratio is -1 to -100

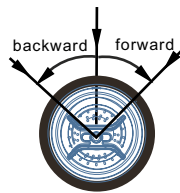

Wheel operation

6: Broken lines (direction and other channels)

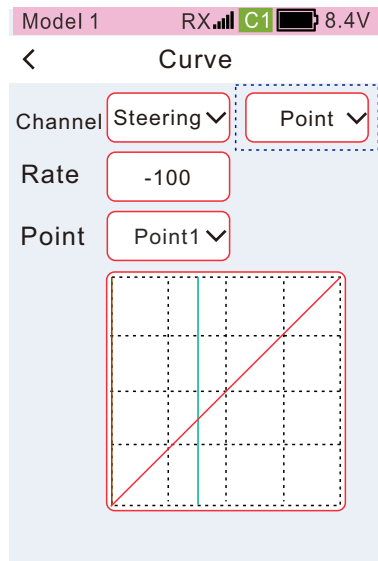

The ratio is -100 to +100, with seven endpoints to set

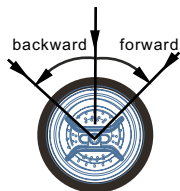

Wheel operation

7. Exponential curve/EXP (Throttle-Forward)

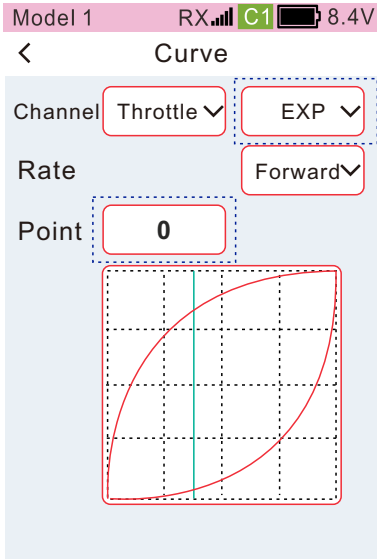

The exponent is +1 to +100

When the index is set to positive, the forward movement tends to be sensitive, and the index is set to negative
When the index is 0, the progress is linear.

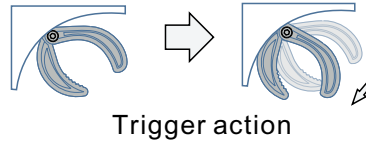

8. VTR (throttle-forward)

9. Polyline (throttle-forward)

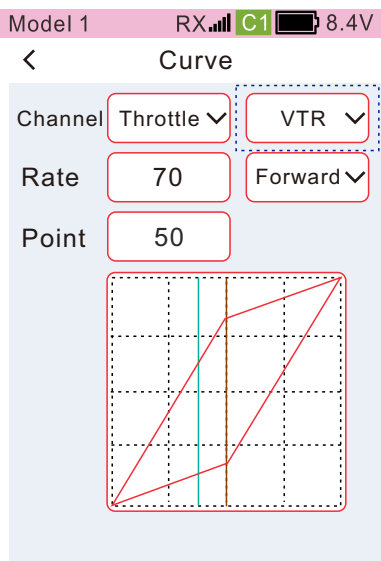

The ratio is +1 to +100

When the ratio is set to positive,

the forward movement tends to be sensitive,

When the ratio is set to negative,

the forward movement tends to flatten out,

When the ratio is zero, the progression is linear.

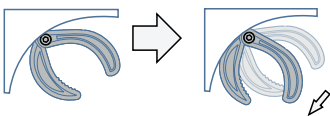

Trigger action

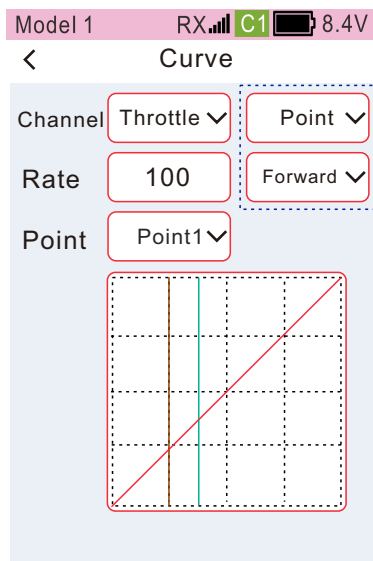

The ratio is -100 to +100, a total of 4 endpoints can be set

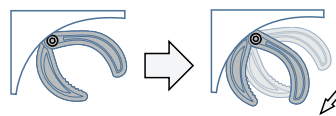

Trigger action

- 10. EXP (Throttle-Brake)
- 11. VTR (Throttle-Brake)
- 12. Polyline (accelerator-brake)

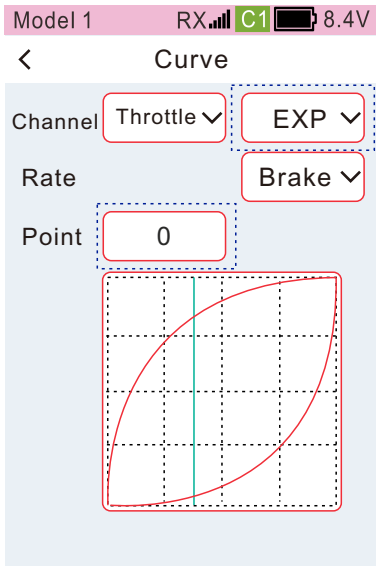

The exponent is +1 to +100
 The action of advancing when the index is set to a positive value Tends to be sensitive, and when the index is set to negative, The forward motion flattens out to zero, the advance is linear.

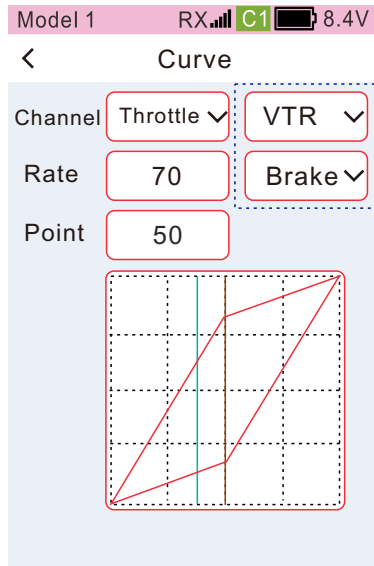

The ratio is +1 to +100
 The forward action when the ratio is set to positive Tends to be sensitive when the ratio is set to negative The forward movement tends to be flat, ratio is 0, the progression is linear.

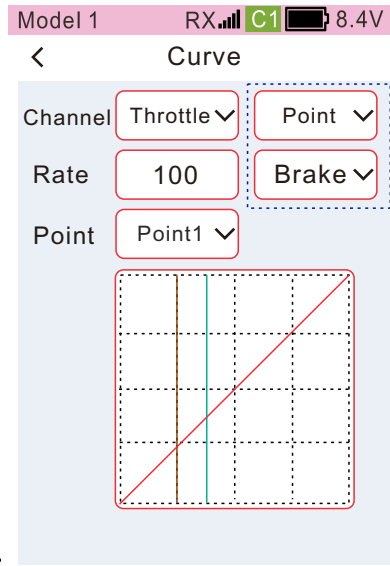

The ratio is -100 to +100, a total of 4 endpoints can be set

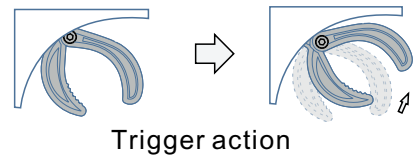

Adjustment method of directional channel exponential curve

Curve Type: Select EXP

Channel: select direction

•Click the "index" setting box, the focus will be displayed as the theme color (the default setting is red), and the bottom bar will display [-] [reset] [+], index When it is set to positive value, the steering action tends to be sensitive; when the index is set to negative value, the steering action tends to be gentle; when the index is 0, the steering is linear.

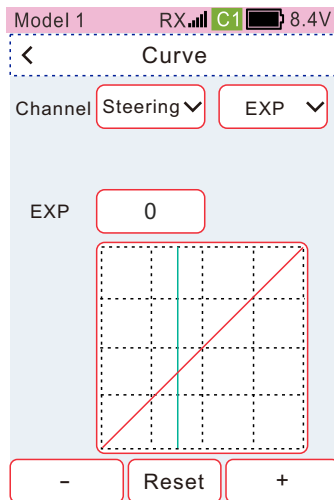
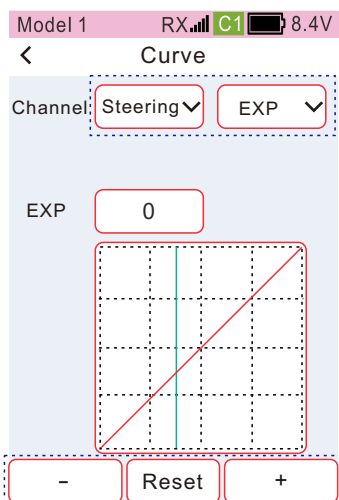

Click [-] and [+] to adjust the index ratio
 Click reset to reset to the default value
 Adjustment range: -100 to +100
 Default value: 0

How to adjust the direction channel VTR curve

- Click the [Rate] or [Point] setting box, focus on the theme color, and display [-] [Reset] [+] in the bottom bar. When the ratio is set to a positive value, the steering action tends to be more sensitive, and the ratio is set to a negative value. When the ratio is 0, the steering action tends to be gentle, and when the ratio is 0, the steering is linear. Adjust the setting value of [Point] to change the position value of point and curve.
- After the setting is completed, click the title bar to exit.

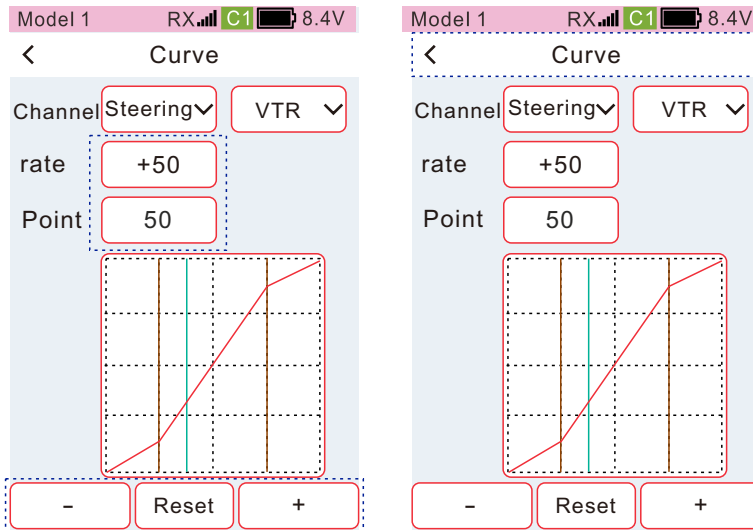

Click [-] and [+] to adjust the index ratio
 Click reset to reset to the default value
 Ratio adjustment range: -100 to +100
 Default value: 0
 Point adjustment range: 1 to 99
 Default value: 50

How to adjust the direction channel Point

- Click the "point" setting box, focus on the theme color, select the endpoint to be set in the drop-down options, and then click the "Ratio" setting box, in the bottom bar Display [-] [reset] [+], set the output ratio of this endpoint, a total of 7 points can be set. You can set the terminals according to your own usage habits. The output ratio from point 1 to endpoint 7.
- When the Settings are complete, click the title bar to exit.

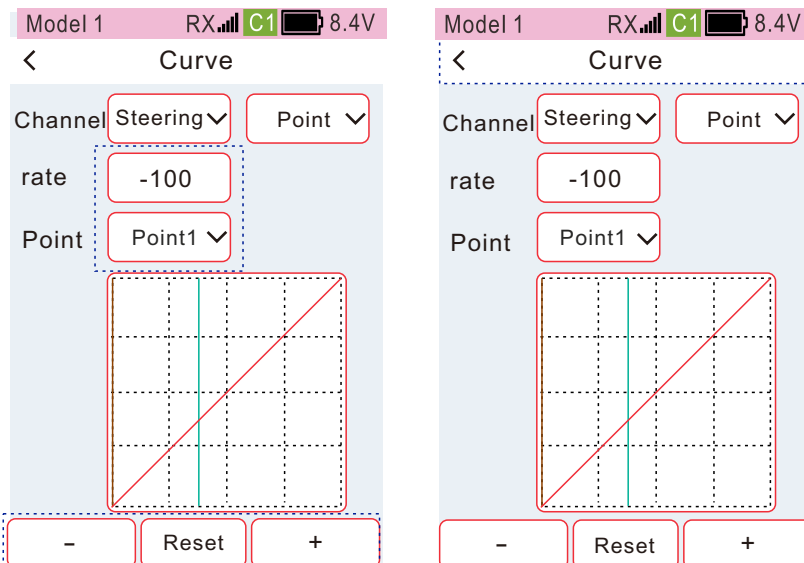

Click [-] and [+] to adjust the index ratio
 Click reset to reset to the default value
 Ratio adjustment range: -100 to +100
 Point adjustment range: endpoint 1 to endpoint 7

The Adjustment Method of the Throttle Channel Exponential Curve

Curve type: Select exponential

Curve Type: Select Exponential

Channel: Select Throttle

Position: select forward, or brake Click the [Index] setting box, focus on the theme color, and display [-] [Reset] [+] in the bottom bar. When the index is set to a positive value, the accelerator forward or braking action tends to be sensitive, and when the index is set to a negative value, the action of the accelerator forward or brake tends to be gentle, and when the index is 0, the accelerator forward or brake is a linear relationship.

- After the setting is completed, click the title bar to exit.

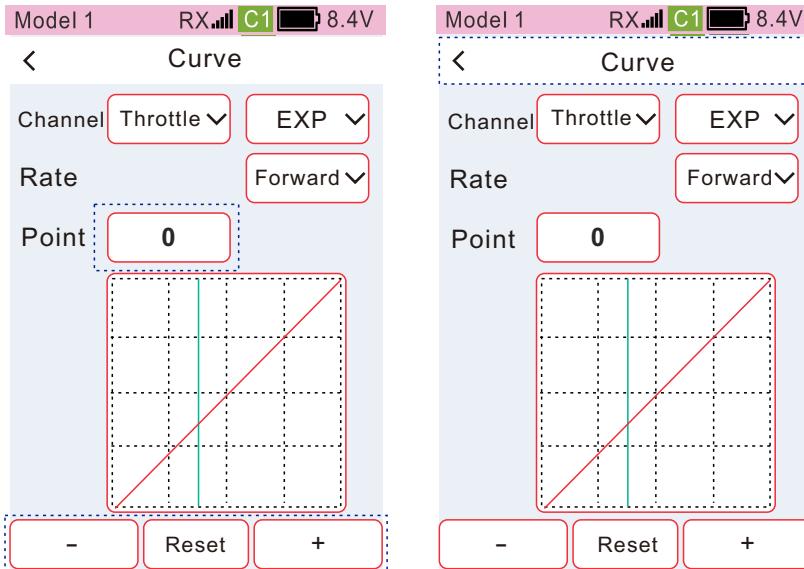

Click [-] and [+] to adjust the index ratio
Click reset to reset to the default value
Ratio adjustment range: -100 to +100
Point adjustment range: endpoint 1 to endpoint 7

Throttle channel - forward, adjustment method of VTR curve

• Click the [Rate] or [Point] setting box, focus on the theme color, and display [-] [Reset] [+] in the bottom bar. When the rate is set to a positive value, the forward action tends to be more sensitive, and the rate is set to a negative value. When the rate is 0, the accelerator forward or brake action tends to be gentle, and when the rate is 0, the accelerator forward or brake is a linear relationship. Adjust the setting value of [Point], you can change the position value of point and curve.

- After the setting is completed, click the title bar to exit.

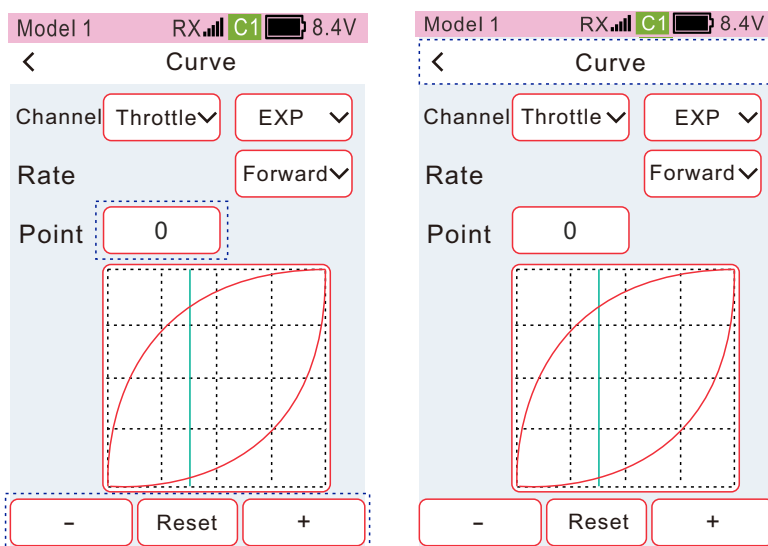

The ratio is +1 to +100
When the rate is set to a positive value, the accelerator forward or brake action tends to be more sensitive. When the rate is set to a negative value, the accelerator forward or brake action tends to be gentle. When the rate is 0, the accelerator forward or brake action is linear.

Throttle channel - forward, adjustment method of polyline

- Click the [Point] setting box, focus on the theme color, select the endpoint to be set in the drop-down options, and then click [Ratio] to display in the bottom bar **[-]** **[Reset]** **[+]**, set the output ratio of this endpoint, a total of 7 points can be set. You can set the output ratio of endpoint 1 to endpoint 7 according to your own usage habits.
- After the setting is completed, click the title bar to exit.

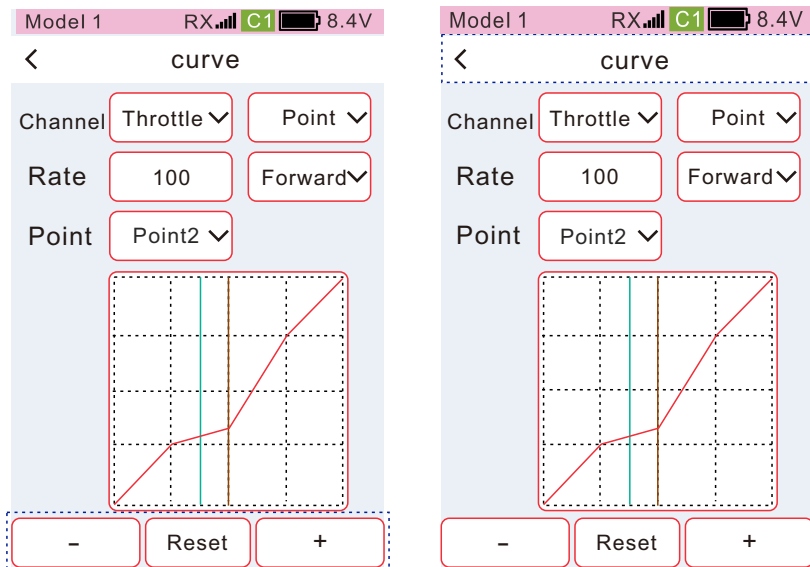

The ratio is -100 to +100
A total of four endpoints can be set

Fail-safe

This function is used to set the action position of the steering gear when the receiver cannot receive the transmitter signal for some reason. F/S (fail safe protection), hold and close modes can be used when the receiver resumes receiving the transmitter signal, which is automatically released.

Note: It can be set normally only when the receiver is connected. For safety, disconnect the engine or motor when starting the test after the setup is complete.

F/S (Fail-safe mode)

When the receiver cannot receive the transmitter signal, the servo output of this channel will act at the pre-set position and keep the position.

Failsafe data is sent from the transmitter to the receiver when clicking the title bar to return to the previous level.

Keep the mode

When the receiver is unable to receive the transmitter signal, remain in the position before the receiver is unable to receive the signal.

Shut down mode

When the receiver cannot receive the transmitter signal, the receiver signal stops the signal output, and the steering gear is in the state of free activity.

• Function path: [Menu] - [Base setting] - [Fail safe]

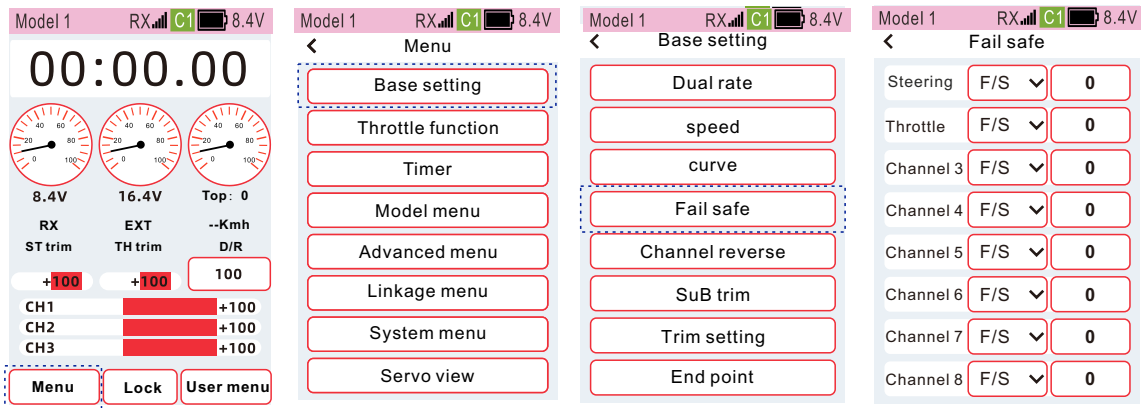

•When the mode is F/S, the value on the right is the output position value of the servo. Click [Value Box], the focus display is the theme color (the default theme is red), get the current channel position value, or set the F/S value in the bottom bar display [-] [Reset] [+]

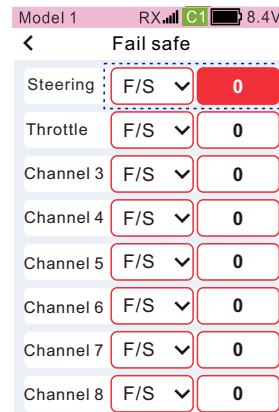

How to set the mode

•Click to set the mode of the corresponding channel of the fail safe protection. Select the desired mode in the drop-down list.

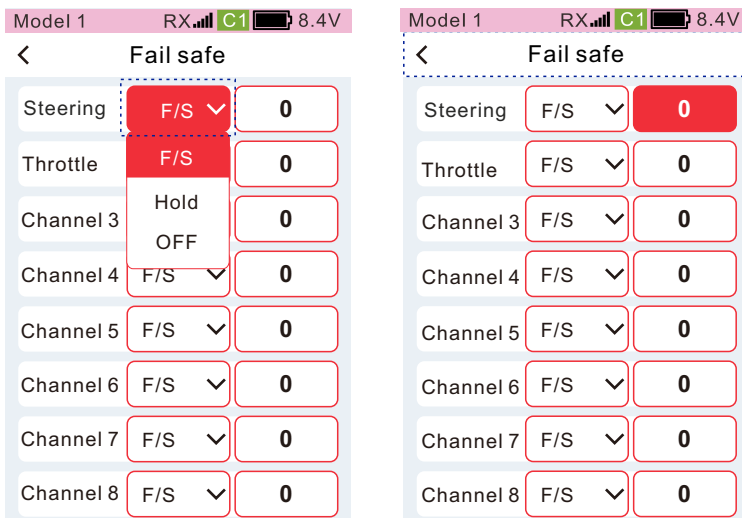

F/S: Fail safe mode

Hold: Hold Mode

OFF: OFF mode

•When the setting is completed, click the title bar to return to the previous level and send the runaway protection data.

Channel reverse

This function can reverse the action direction of the direction, throttle, channel 3 to channel 9 servos. After setting the reverse direction, when you move the position from the midpoint, the moved position will become the other side of the midpoint.

•Function path: [Menu] - [Base setting] - [Channel reverse]

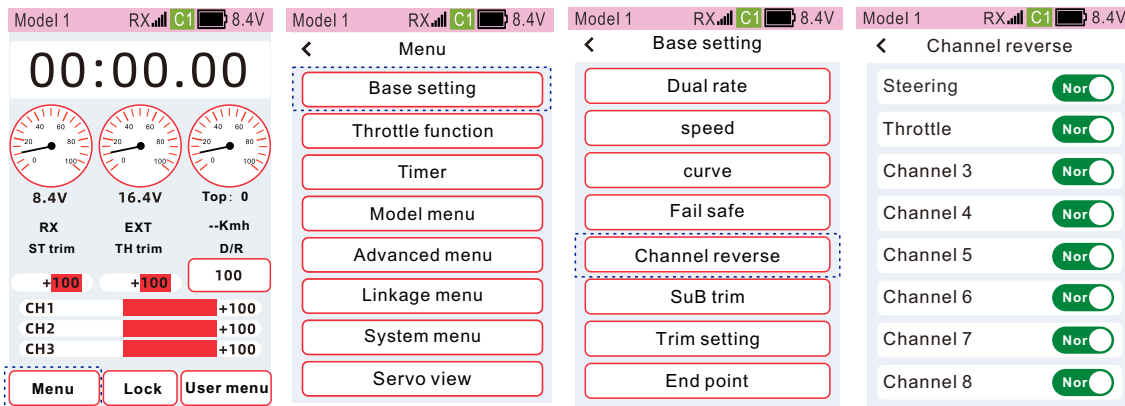

The method of setting positive and negative

Click on the corresponding channel Nor or Rev Set the direction of steering gear. As is shown as Nor Indicates that the steering gear output is positive. As is shown as Rev Indicates that the steering gear output is reversed. After setting, click the title bar to return to the upper-level menu.

Sub trim

This function is used to assemble the model. When using the servo rocker of each servo to connect the parts with the connecting rod, the mechanical structure still cannot be adjusted to the midpoint position. By adjusting the sub trim, the servo rocker arm is in the center position.

•Function path: [Menu]-[Base setting]-[Sub trim]

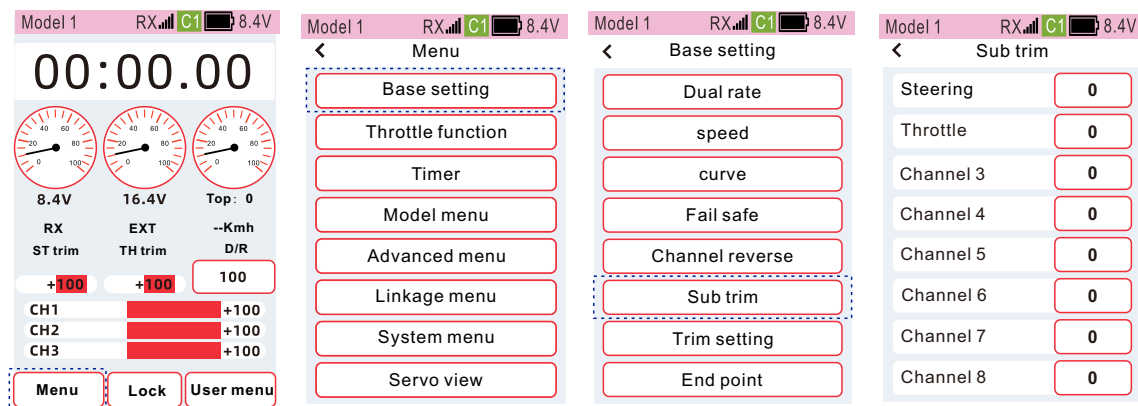

Sub trim adjustment method

Please refer to the manual of the model kit, install the mechanical mechanism, and make the servo rocker arm as close to the center position as possible.

Open the [Sub trim] setting interface, and set the setting values of each channel of condition direction, throttle, channel 3 to channel 9, respectively.

① Click [Setting Box], the focus is displayed as the theme color (the default theme is red), and the bottom of the screen displays [-] [Reset] [+].

② Click or long press [-][+] to adjust the ratio.

③ After the settings are completed, click the title bar to return to the previous menu.

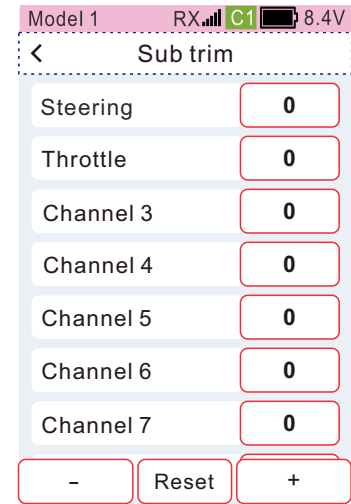
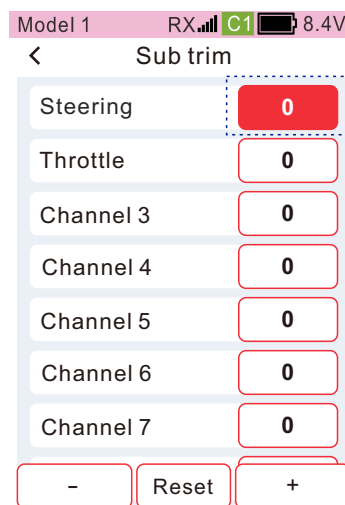

Trim setting

This function can set the digital trim mode of direction, throttle, channel 3 to channel 9, and trim neutral point. The physical trim buttons corresponding to each channel can be set in [Advanced menu]-[Channel setting]-[CH set].

Default setting:

DT1: Direction trim

DT2: Throttle trim

Model:

Midpoint mode: Only change the position of the neutral point of the servo, without changing the left and right strokes of the servo.

Parallel mode: The neutral point is shifted to the left and right, and the left and right strokes of the servos follow the overall shift of the neutral point.

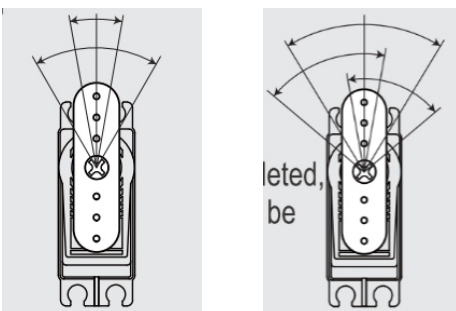

Function path: [Menu] - [Base setting] - [Sub trim]

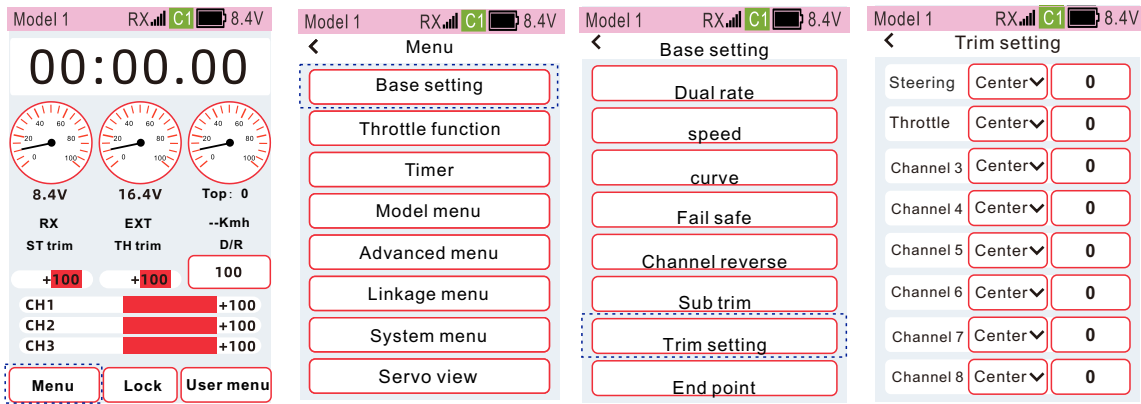

How to make trim setting

- ① Click the corresponding channel Trim setting mode setting item, in the drop-down option, select the [Center] or [Parallel] mode according to the usage requirements.
- ② Click the setting box of the corresponding channel trim amount, the focus display is the theme color (the default theme is red), and the bottom of the screen displays [-] [Reset] [+]. Click or long press **[-]** **[+]** to adjust the sub trim value.
- ③ After the setting is completed, click the title bar to return to the previous menu

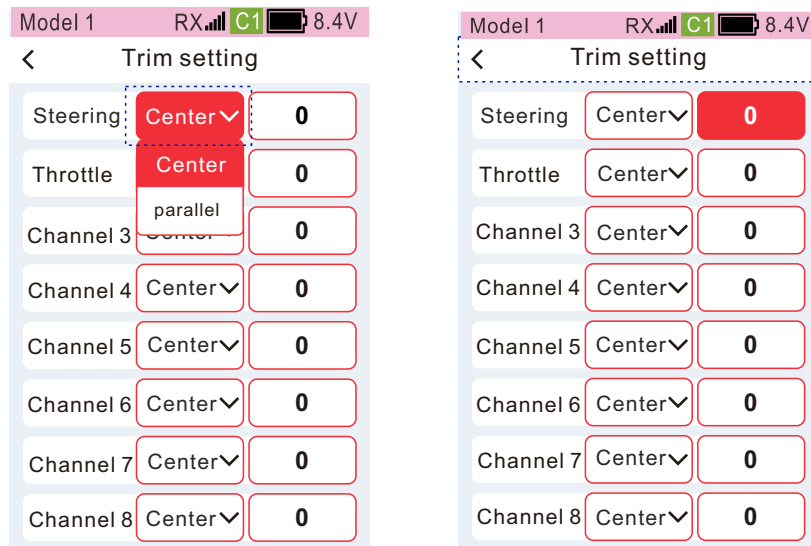

End point

This function is used to adjust the left and right angles of the direction, the forward and brake of the accelerator, the adjustment of the up and down strokes of channel 3 to channel 9, and the stroke of one side can be adjusted independently according to the characteristics of the model.

Tip: The end point setting determines the limit of the channel, but when the following functions are adjusted, it may cause the range of the total stroke to be exceeded.

- Sub trim (all channels)
- Program mixed sub-channels (all channels)
- Throttle off (throttle channel)

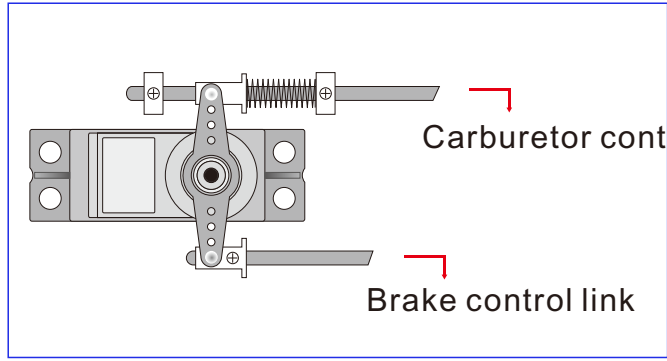
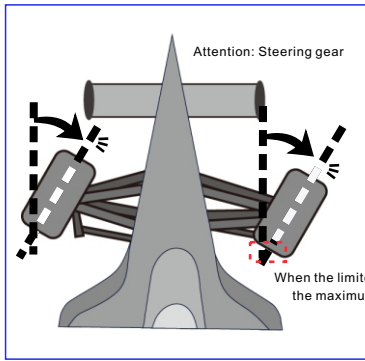

Adjust the steering servo, when the steering servo outputs the maximum stroke, the model steering mechanical structure will not be squeezed and deformed.

When the carburetor of the engine is fully opened, fully closed and the brake is fully braked, the mechanical structure of the model will not be squeezed and deformed.

Setting path: [Menu] - [Base setting] - [End point] - [End point]

• Select the channel to be set

Click the channel button and select the channel to be set from the drop-down list.

End point, setting method of left and right ratio

①Click the left or right setting box, the focus display is the theme color (the default theme is red), and the bottom of the screen displays [-][Reset][+].Click or long press **[-]** **[+]** to adjust the stroke amount.

②The setting is completed, click the title bar to return to the previous menu

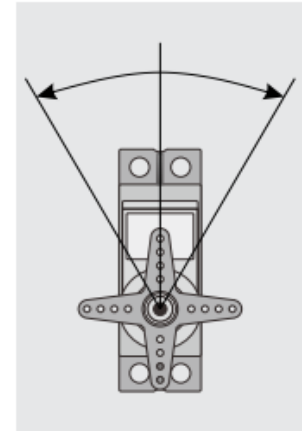
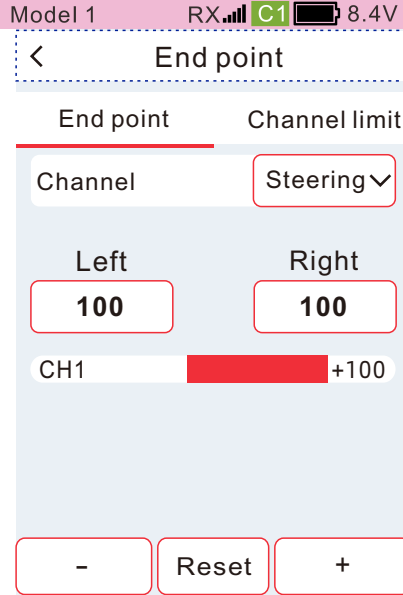
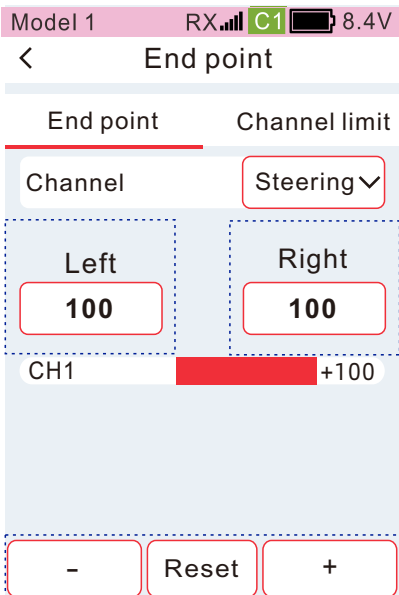

Servo channel left/right travel

Channel limit

This function is used to limit the maximum stroke of the final output of the servo. Even if other mixing functions are superimposed, the maximum stroke of the servo can still be limited to protect the physical connection from damage.

Function path: [Menu]-[Base setting]-[End point]-[Channel Limit]

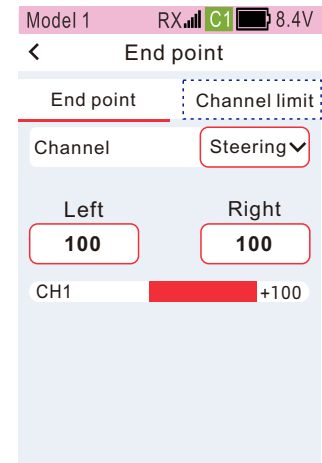
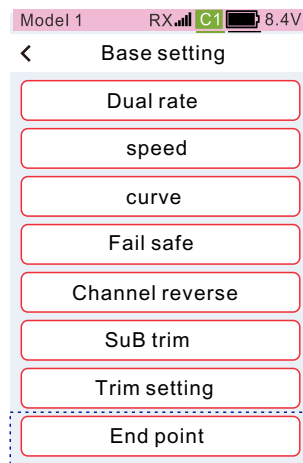
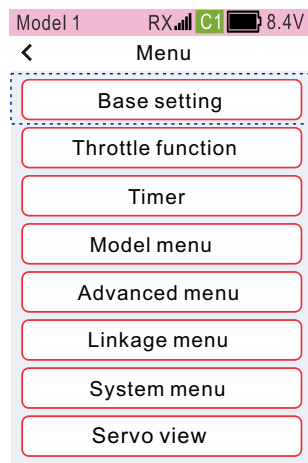
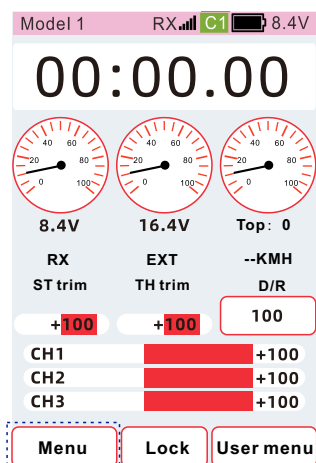

Select the channel to be set
 ●Click the channel button and select the channel to be set from the drop-down list.

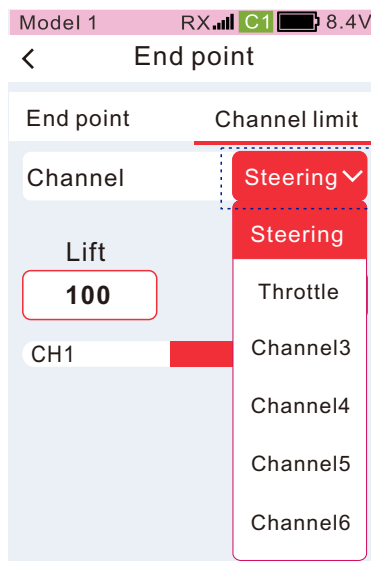

Travel limit, setting method of left and right ratio

①Click the left or right setting box, the focus display is the theme color (the default theme is red), and the bottom of the screen displays **[-] [Reset] [+]**. Click or long press **[-] [+]** to adjust the end point.
 ②The setting is completed, click the title bar to return to the previous menu

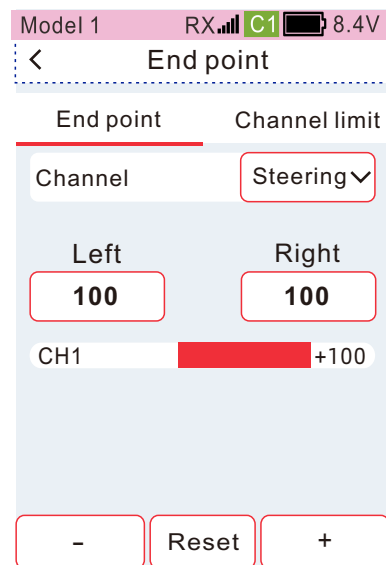
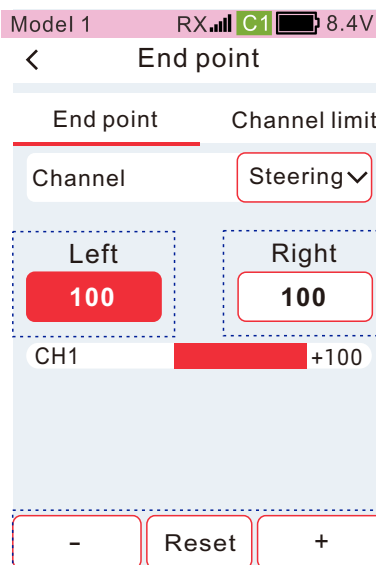

Throttle function

A.B.S

Full-time four-wheel drive model, when turning, may turn too sharply and the model rushes out of the runway. Activate the A.B.S function to let the throttle output intermittent point-brake action, so that the model can achieve a smooth turn.

Operate the brake, throttle servo or electronic brake to intermittently form a point brake action. You can set the brake return, delay, cycle, duty cycle, and brake trigger point parameters.

In [Advanced menu] - [Brake mixing], you can set whether the A.B.S function is enabled for channel 3 and channel 4 respectively.

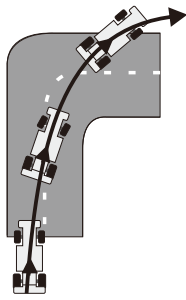

A.B.S not enabled

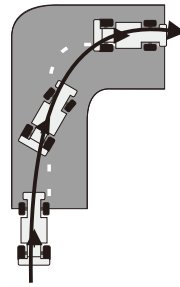



A.B.S enabled

Function path: [Menu]-[Throttle Function]-[A.B.S]

A.B.S setting

When the status is set to [ON], the function is enabled, and when it is set to [OFF], the throttle idle setting is not enabled.

: Indicates that the state is on

: Indicates that the status is off

Brake return setting

Brake return amount. When the brake action is clicked, the return ratio of the corresponding servo position. 1~100
The return amount is 1~100%.

Click the setting box of [Brake return], the focus display will be the theme color (the default theme is red), and the bottom of the screen will display [-] [Reset] [+].

Click or long press [-] [+] to adjust the return amount

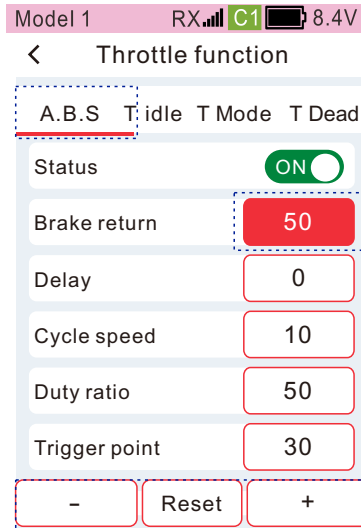

Delay amount setting

Start A.B.S delay amount. The delay time for starting this function when the A.B.S effective conditions are met.

Set to 0: no delay;

set to 1~100: delay about 0.01~2 seconds. Click the setting box of [Delay], the focus is displayed as the theme color (the default theme is red), and the bottom of the screen displays [-] [Reset] [+].

Click or long press [-] [+] to adjust the delay amount.

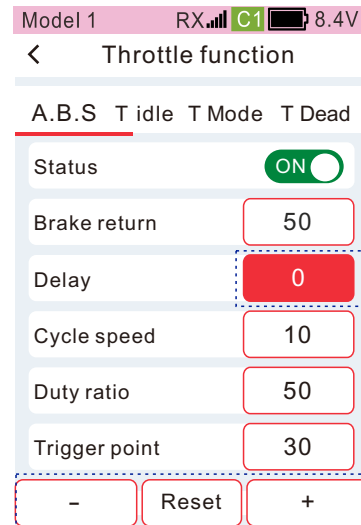

Cycle speed settings

Tap the cycle speed. The time required for one cycle to brake and release the brake.

The smaller the setting value, the less time it takes to click; on the contrary, the larger the setting value is, the more time it takes to click.

Click the setting box of [Cycle speed], the focus is displayed as the theme color (the default theme is red), and the bottom of the screen displays [-] [Reset] [+].

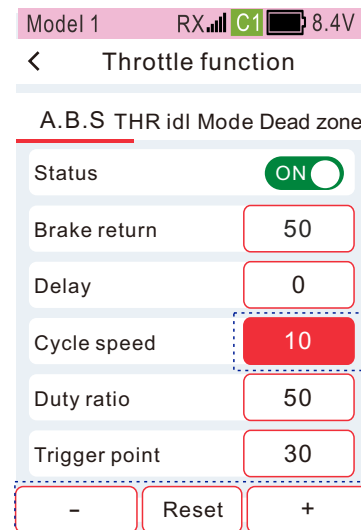

Click or long press **[-]** **[+]** to adjust the cycle amount.

Duty ratio setting

Point-to-point efficiency, the proportion of braking time to the entire point-to-point time.

Setting range: 20% to 100%

Default: 50%

Click the setting box of [v], the focus display will be the theme color (the default theme is red), and the bottom of the screen will display [-] [Reset] [+].

Click or long press **[-]** **[+]** to adjust the Duty ratio.

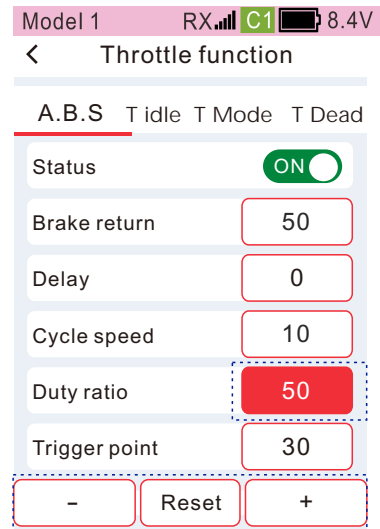

Brake trigger point settings

The trigger position where A.B.S comes into play.

10% to 100% : When the brake position reaches 10 to 100%, the A.B.S function is enabled.

1. Click the setting box of [brake trigger point], the focus is displayed as the theme color (the default theme is red), and [-] [Reset] [+] is displayed at the bottom of the screen.

Click or long press [-] [+] to adjust the position of brake trigger point.

2. After setting, click the title bar to return to the upper-level menu

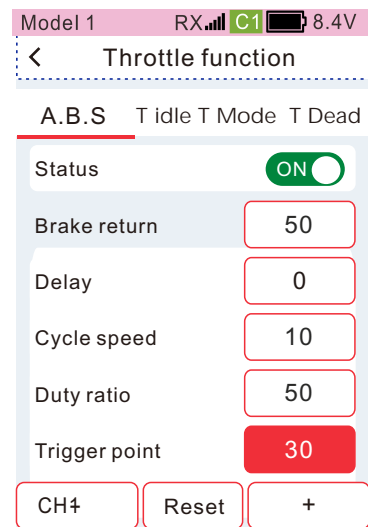
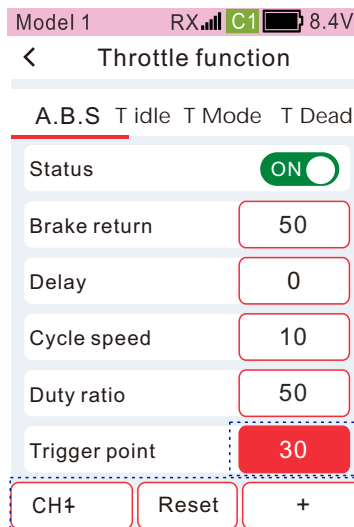

Throttle idle

When this function is used in the gas-powered model, it can improve the starting performance of the engine by increasing the idling speed of the gas-powered vehicle. When using this function, you need to click the [Advanced menu]-[Channel setting] - [CH set] assign the physical switch of the throttle idle speed-state. The neutral point of the accelerator will be compensated on the acceleration side or the braking side. When the idle speed function is activated, the neutral point compensates and does not affect the maximum stroke.

When setting the ratio,

The prefix is "up", which means compensation for the throttle side. The prefix is down, which means compensation on the brake side.

Voice broadcast:

On: Throttle idle

Off: Idle release

Function path: [Menu] - [Throttle Function] - [THR idle]

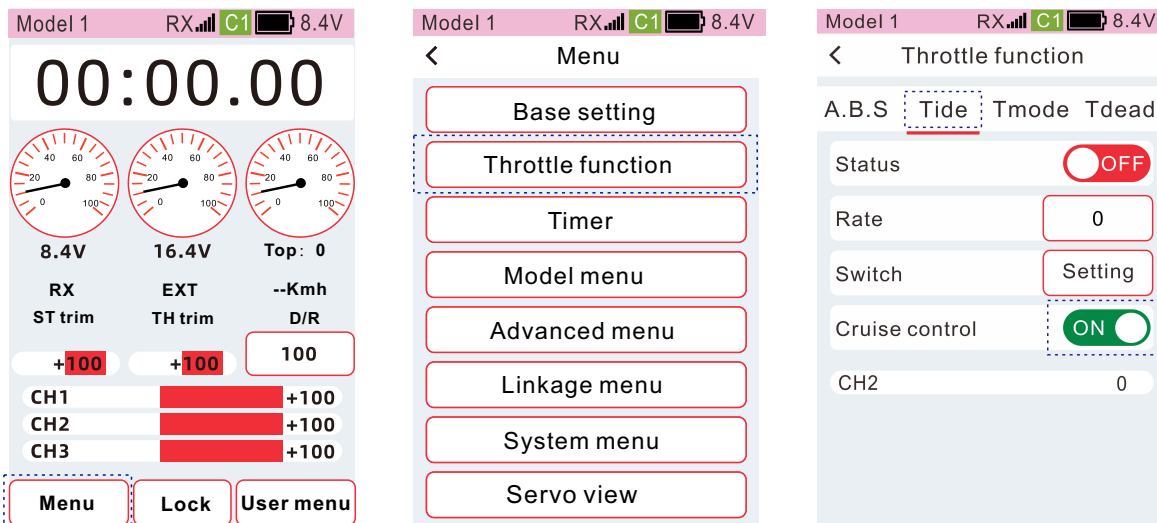

Throttle idle setting

When the status is set to [ON], the function is enabled, and when it is set to [OFF], the throttle idle setting is not enabled.

: Indicates that the state is on

: Indicates that the status is off

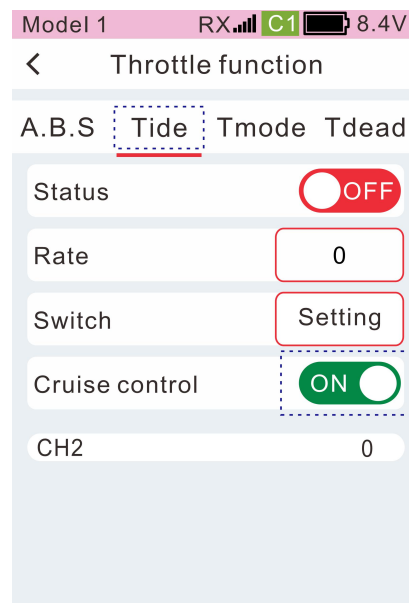

How to Set Throttle Idle Ratio

- ① Click the [Rate] setting box, the focus is displayed as the theme color (the default theme is red), and the bottom of the screen displays [-] [Reset] [+]. Press or long press [-][+] to adjust idle speed ratio.
- ② The setting is complete, click the title bar to return to the previous menu

Click on the switch and select [Setting].
On PS1, PS2, PS3, SW1, SW2, set the control function to [Throttle idle-state] on/off.

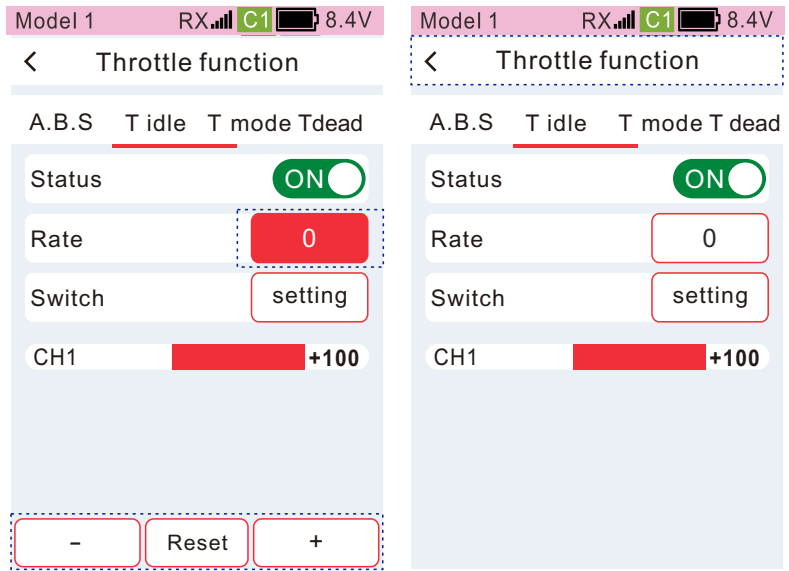

Cruise control setting method

When the status is set to [ON], the function is enabled,
When it is set to [OFF], the idle setting is not enabled.

- means the state is power on
- means the state is power off

Default: CH9 for cruise response channel,
PS2 enabled/off, CH9 and CH2 mixed

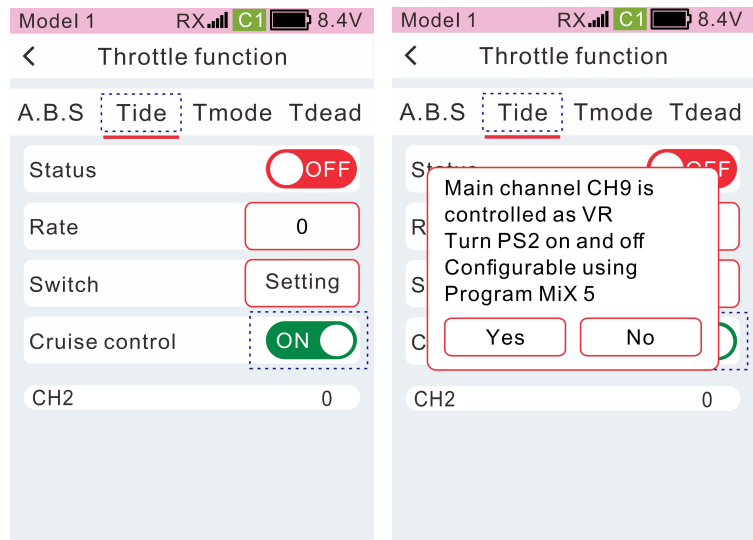

How to set the control switch and response channel

Path: 【 Menu 】 - 【 Advanced Menu 】 - 【 Channel Setting 】 - 【 CH set 】

Default: VR [Channel 9]

Default: PS2 【 Programming Mixing 5 】

Set cruise control, throttle speed switch,

For details, see [Page 61 - Channel Setting]

Path: 【 Main menu 】 - 【 Advanced Settings 】

- 【 Programming Mixing 】 - 【 Programming Mixing 5 】

Default: Programming Mixing 5 【 Programming Mixing 5 】

Set cruise control, response channel on/off,

For details, please see 【 Page 74 - Programming Mixing 】

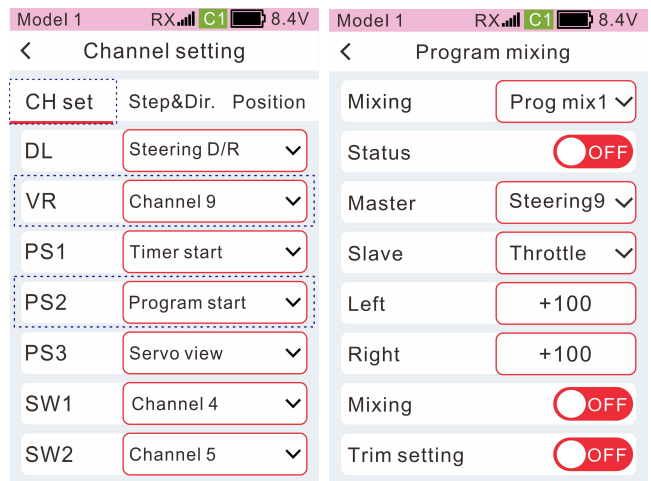

Throttle mode

This function can set the action ratio of the accelerator channel forward and brake, there are totally 3 other modes: [forward 50: brake 50], [forward 70: brake 30], [forward 100: brake 0] (used by ship model and other models)

Amount of brake

When directly adjusting the accelerator to trigger the brake, the minimum stroke of the brake output.

Function path: [Menu] - [Throttle function] - [THR Mod]

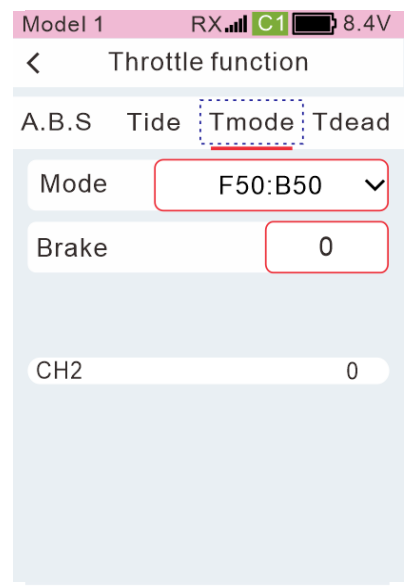
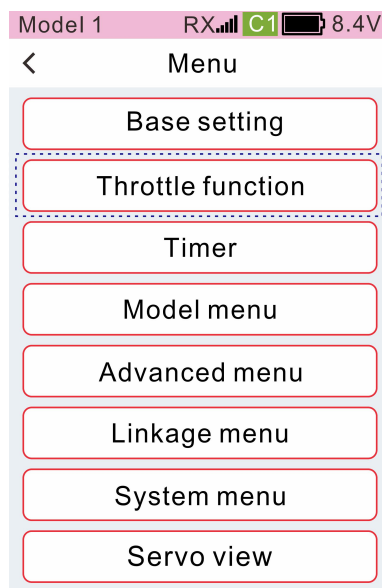
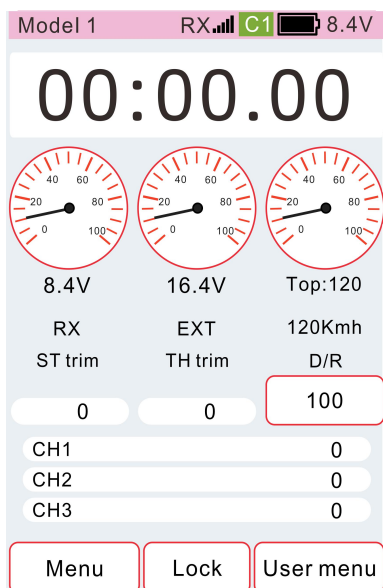

Throttle mode settings:

1. Click the THR mode item, and in the drop-down options, select [Forward 50: Brake 50], [Forward 70: Brake 30] or [Forward 100: Brake 0] mode.

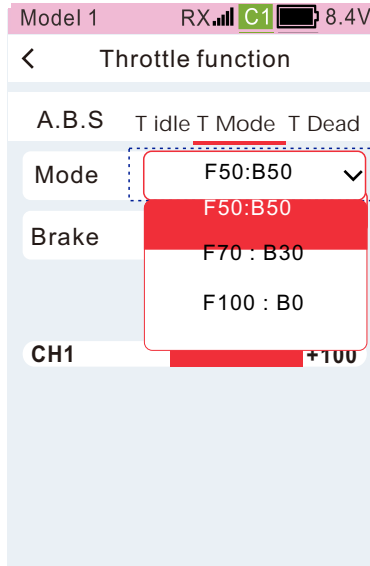

Brake amount setting:

① Click the setting box of [Brake Amount], the currently selected focus setting box will be displayed as the theme color, and the bottom of the screen will display [-] [Reset] [+]. Click or long press **[-]** **[+]** to adjust the braking amount.

② The setting is completed, click the title bar to return to the previous menu

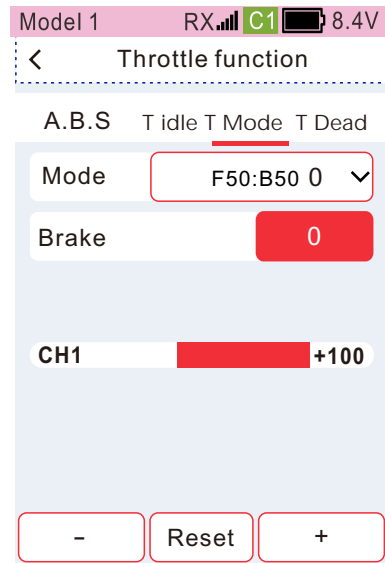
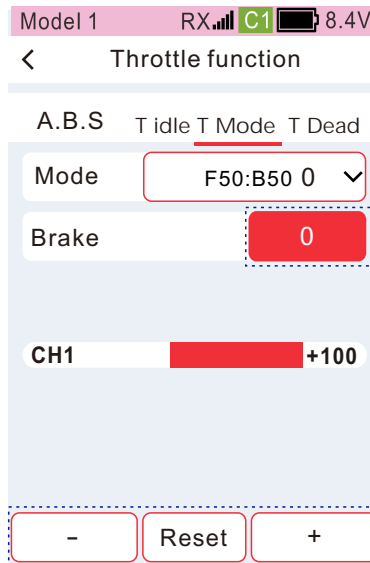

Dead Zone

This function can set a "dead zone" for the throttle control, in this area, the throttle always output the median value, moving the trigger throttle channel does not change, and the output value will change beyond the area. Throttle dead zone can be set according to needs, there are forward, midpoint, brake three modes.

Forward

After the dead zone is exceeded, the throttle directly outputs this initial value to accelerate forward.

Midpoint

Deadzone range

Brake

After the dead zone is exceeded, you can brake or directly output the initial value to accelerate backward.

Path: Menu-Throttle function-Dead zone

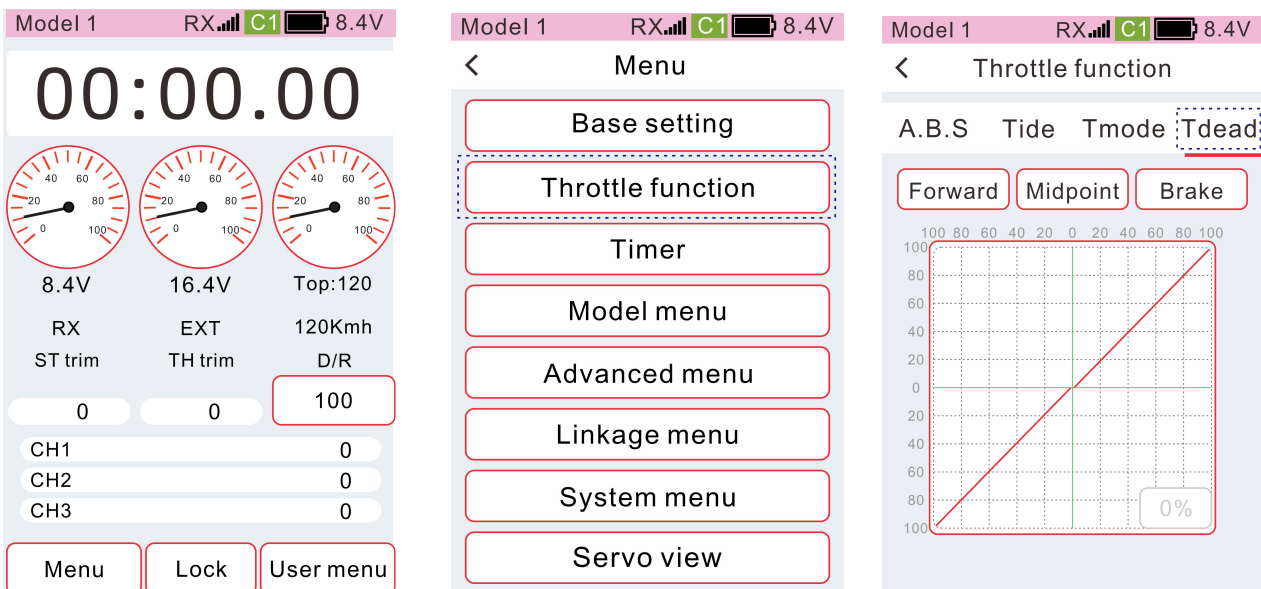

Throttle dead zone setting

Click the dead zone setting item and select the mode according to the use needs.

The current focused setting

box is displayed as the theme color

(the default theme is red). The bottom of the screen displays [-] [Reset] [+]. Click or hold [-] [+] to adjust the dead zone value.

② After setting, click the title bar to return to the upper-level menu.

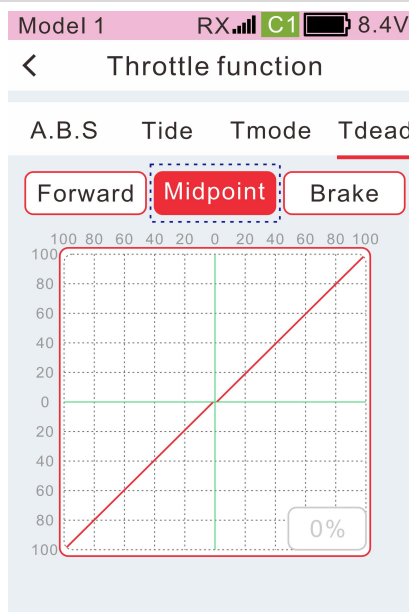

Timer

Timer

The timer function can be selected from three timing modes: up timing, countdown timing, and lap timing.

Function path: [Menu]-[Timer]-[Timer]

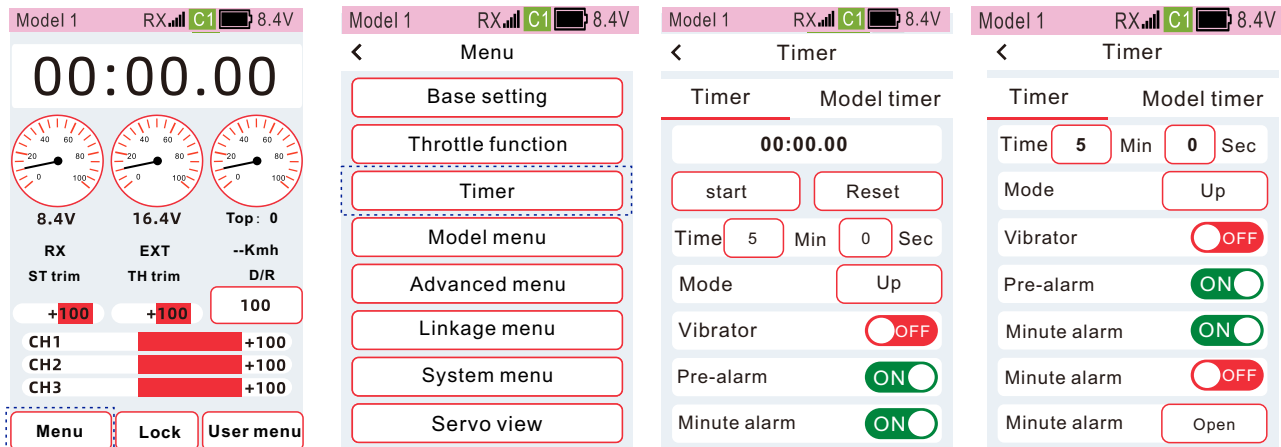

Start/Pause: Tap the timer to start/pause the timer.

Reset: Click to reset the timer.

Time: Set the timer warning time.

Mode: Select up time, count down time, lap time.

Vibration: There is a vibration reminder when the timer is finished.

Pre-alarm: Distance Timer Completed In the first 10 seconds, the speaker emits 10, 9, 8, 7, 6, 5, 4, 3, 2, 1, and the timer has timed out voice reminder switch.

Broadcast every minute: Timing every 1 minute, the speaker voice broadcasts the 1st minute, the 2nd minute, ... the Nth minute.

Trigger: You can control the timing start/pause by setting the trigger position.

Lap list: Open and jump to the timing list interface.

Timer setting way

Click the setting box of [min] or [sec], the focus will be displayed as the theme color (the default theme is red), and [-] [Reset] [+] will be displayed at the bottom of the screen.

Click or hold [-] [+] to adjust the amount of travel.

② After setting, click the title bar to return to the upper-level menu

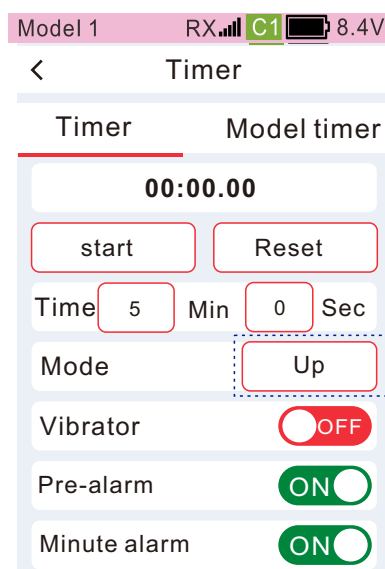

Count down

Press the PS1 key to switch between start and pause, and accumulate the total time between each start and stop. The throttle trigger can be used as a timing start, pause control. Even in the non-timer function interface, the timer can still be controlled by buttons Start, Pause, Reset.

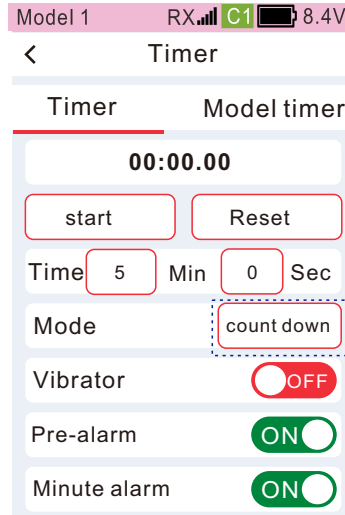

Lap timer

● After starting the lap time, the time of each lap will be recorded in the sequence of each button press. (Maximum save 100 laps) ● In [Advanced menu]-[Channel setting]-[CH set] setting the function of the button [Timer-Lap Time], you can use the button to count the number of laps. Each time you press it once, it will count as one lap, and the speaker will emit The 1st lap, the 2nd lap, ... the voice broadcast of the Nth lap. Timing List Timer Timer Model Timing 00:00.00 Start Reset Time Minutes Seconds Reminder 10 seconds before pattern vibration Reminder every minute Off On On Countdown

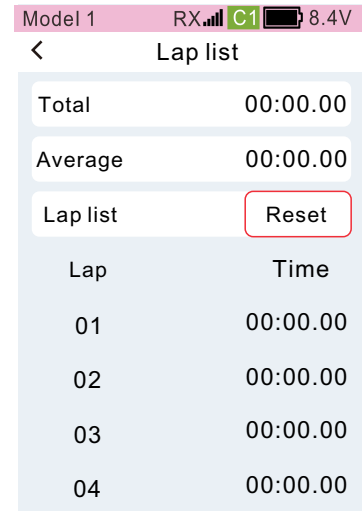
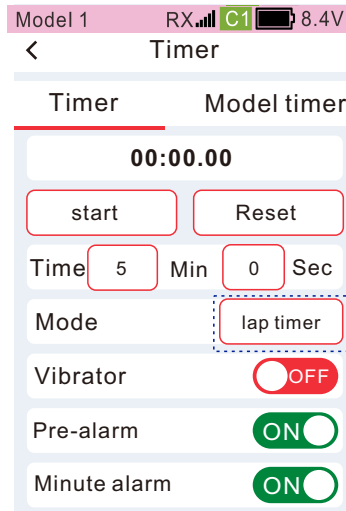

Total Time

Total time = 1 lap time + 2 lap time + 3 lap time + ... 100 lap time

Average time = 1st lap time + 2nd lap time + 3rd lap time + ... 100th lap time / number of laps

Reset: Clear the lap list time.

Timer timing time setting method

①Click the setting box of [Minutes] or [Seconds], the focus is displayed as the theme color (the default theme is set to red), and the bottom of the screen displays -

Reset + . Click or long press

- + Adjust the stroke amount.

The setting is completed, click the title bar to return to the previous menu

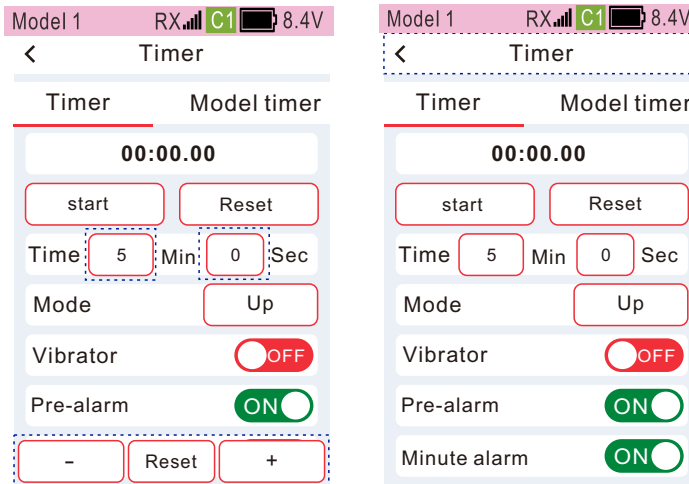

Model timer

This interface can display the accumulated usage time of the currently selected model, and the timing mode can be set to three modes: boot timer, wheel control, and trigger control.

Function path: [Menu]-[Timer]-[Model Timer]

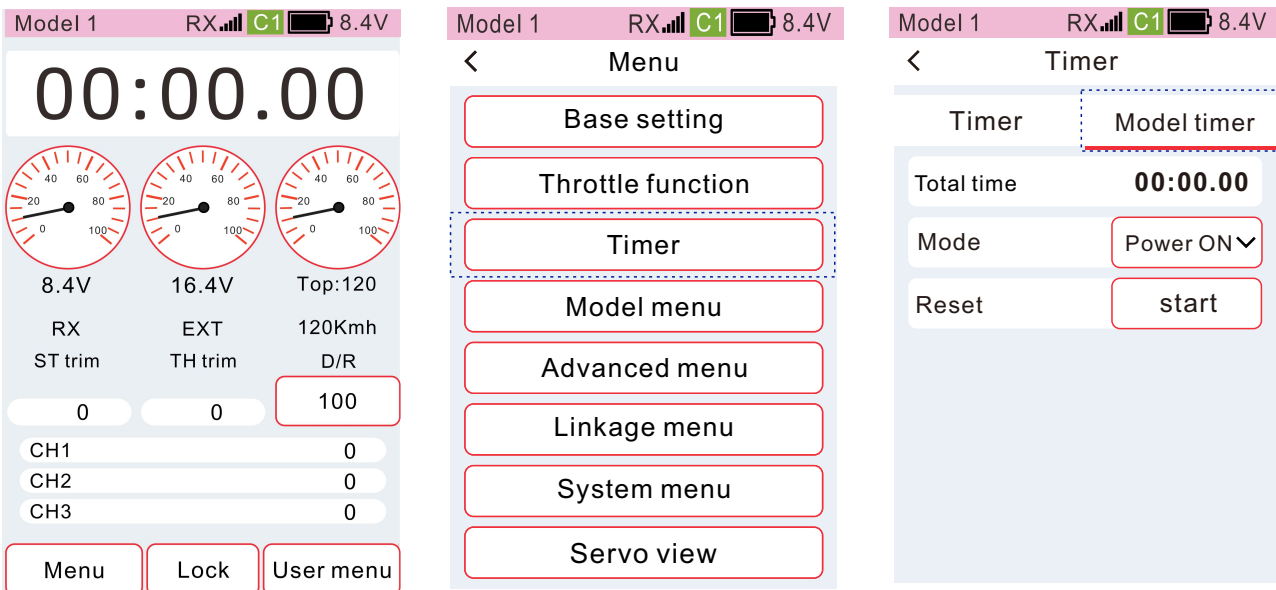

Total time:

The cumulative usage time of the currently selected model

The maximum timing time: 99 hours, 59 minutes and 59 seconds.

If it exceeds, the timing will be reset to zero.

Model:

Sets how the control timer starts and pauses.

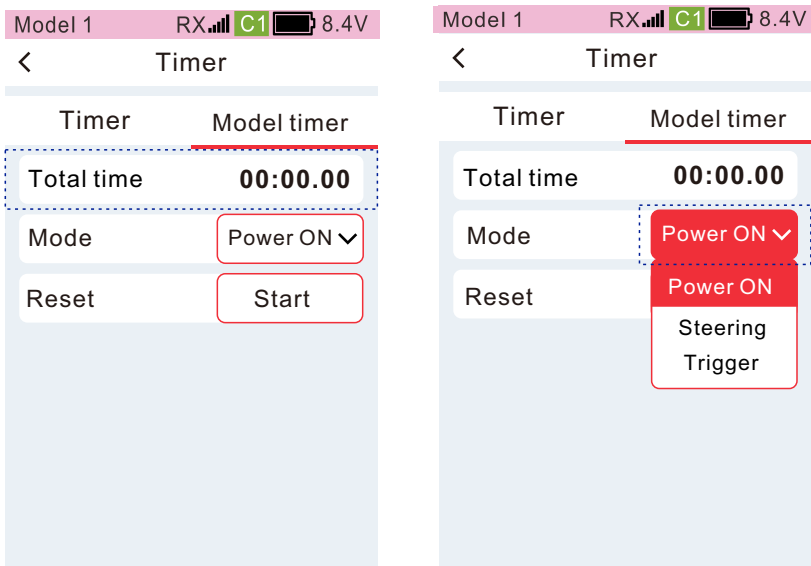

Power on:

Start timing automatically when power on.reel:

Steering:

Control the timing start and pause through the steering. Wheel control position setting path: [Advanced menu]-[Channel setting]-[Position]-[Steering]

Trigger:

Control the timer start and pause through the trigger.

Trigger control position setting path: [Advanced menu]-[Channel Setting]-[Position]-[Trigger]

Reset:

Clear the accumulated usage time of the currently selected model.

Steering trigger's position setting

Path: [Menu] - [Advance Setting]
- [Channel Setting] - [Position]

Setting method of trigger and runner
[Position]] Click [Position]

For details, please see 【 Page 66 -
Gear Setting 】

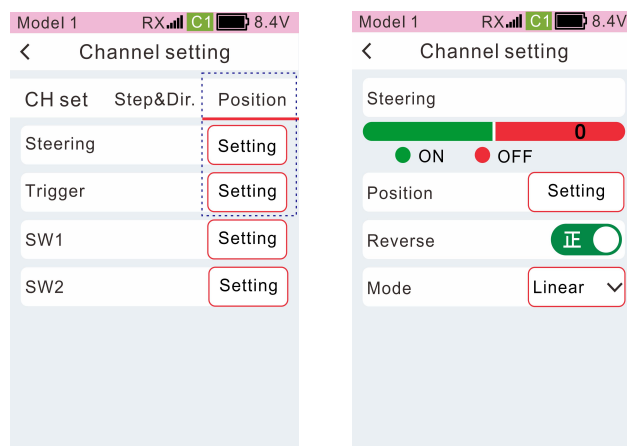

Model menu

Model select

The remote control has 40 sets of models to choose and store. The currently selected is the focused green box

1. Model 1, Model 17.... Model 40, same ID. One controls multiple receivers. Specific method: two receivers are paired with the code, powered on at the same time, and both receivers are controlled.
2. How to use: transmitter, communication settings, receiver settings, receiving power on alone, setting the channel output sequence, such as No. 1 receiving (1-6 channels), No. 2 receiving (7-9 channels)
3. Model 2 - Model 16, with different IDs. Specific phenomenon: When two vehicles are powered on at the same time, only one vehicle can be controlled.

Function path: [Menu]-[Model Menu]-[Select]

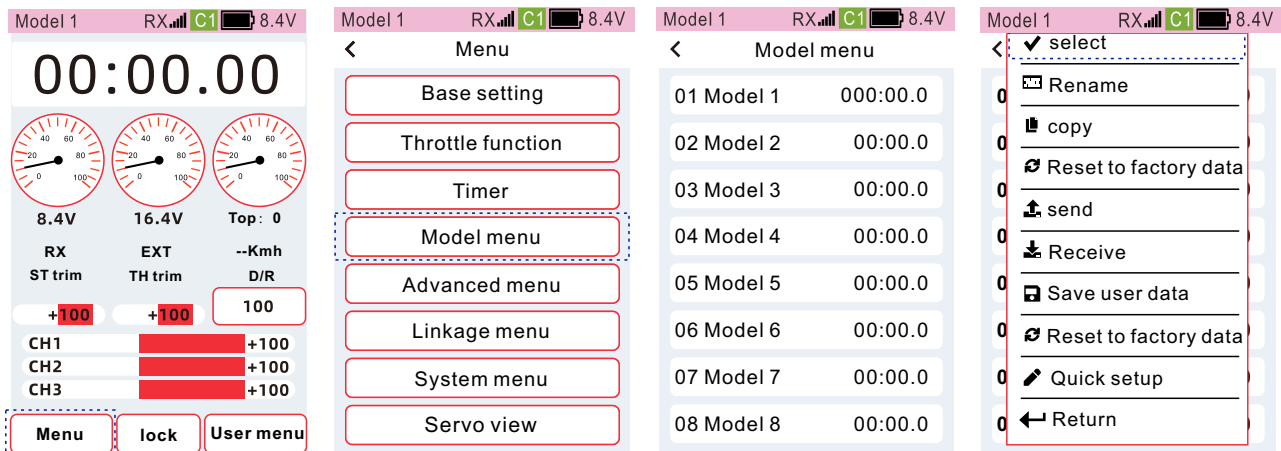

Rename

To differentiate each model, name your model using upper and lower case letters, numbers, and punctuation.

Function path: [Main menu] - [Model menu] - [Select] - [Rename]

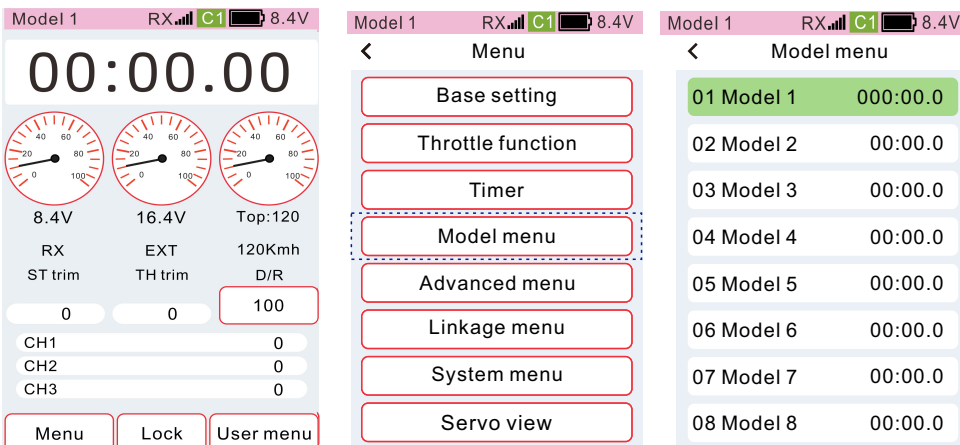

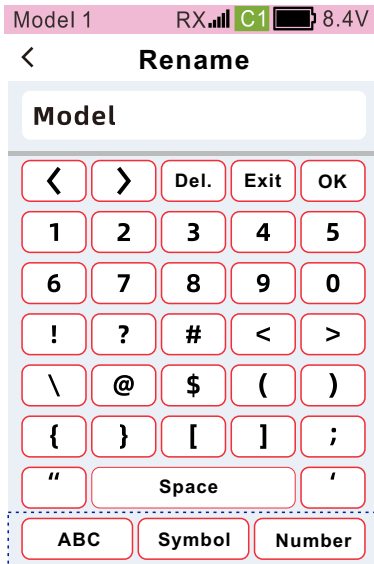
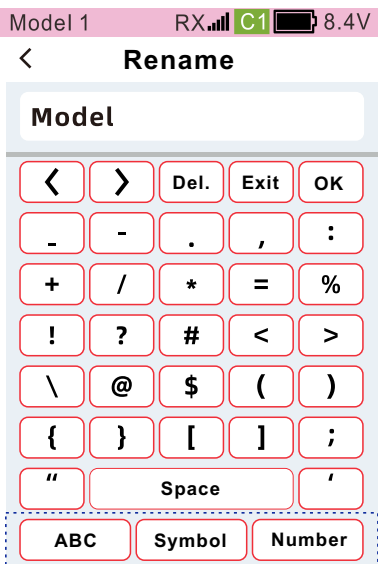
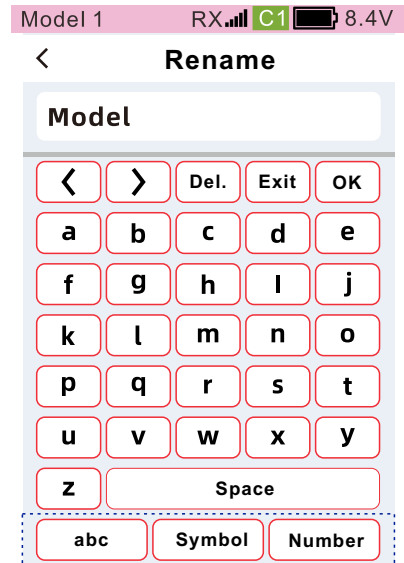
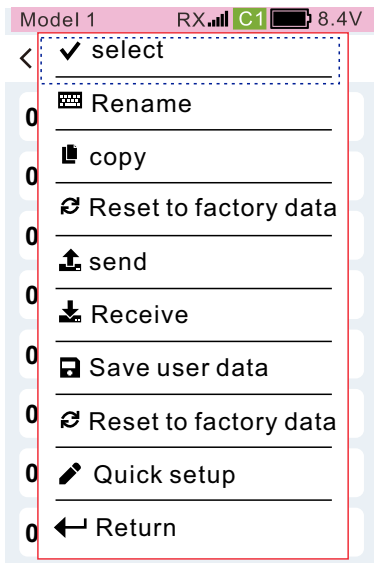

1. Move the cursor to the character to be modified. Click [<] or [>] to move the cursor left or right.
2. Select characters In the following keyboards of the model name, switch between uppercase and lowercase, symbols and numbers, select the required characters, and name them for confirmation.

Copy

The currently selected model data can be copied to another model data to change the settings of the current model data. Copies the setup data of the selected model to another set of models.

Function path: [Menu]-[Model menu]-[Copy]

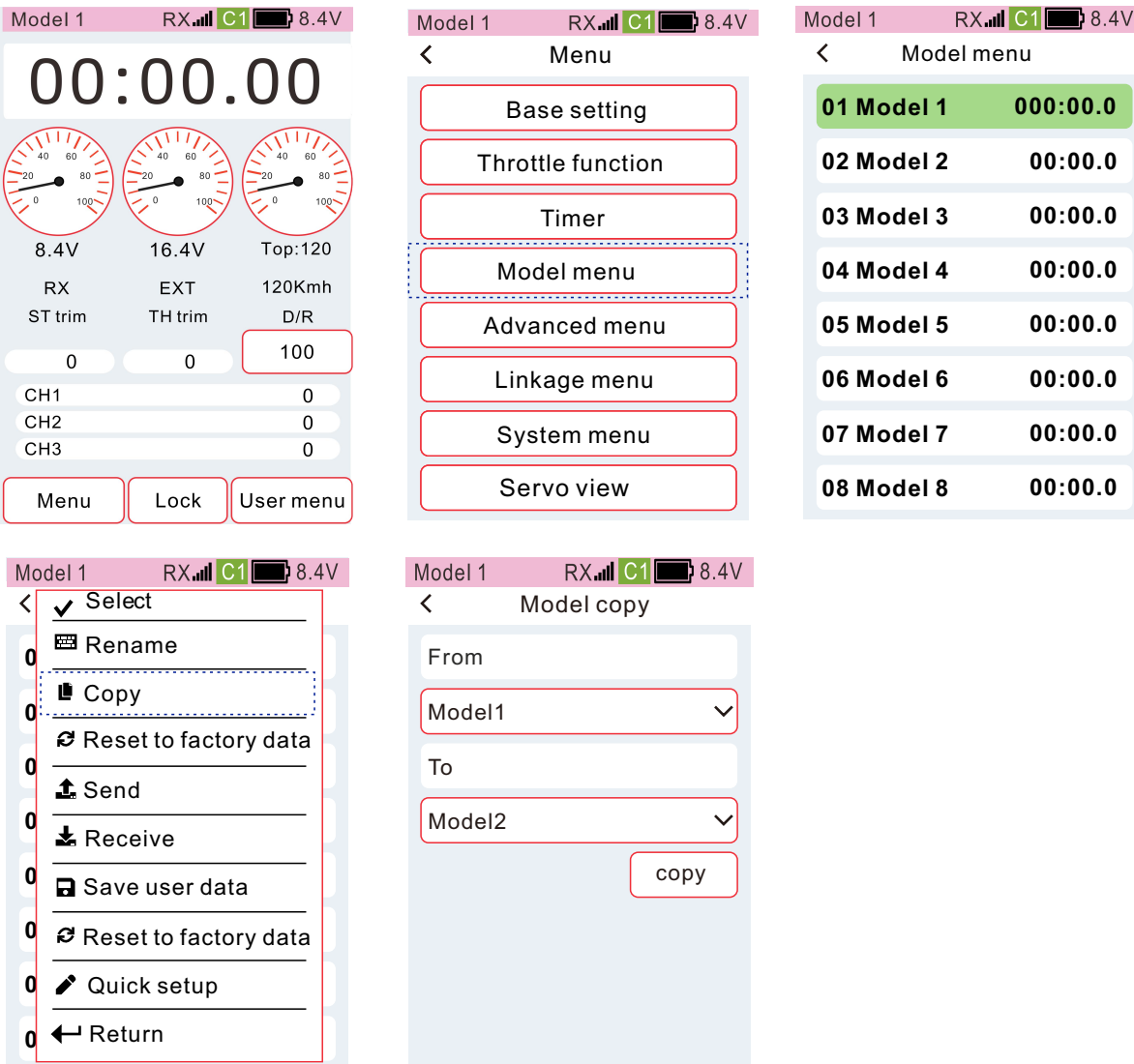

Selection of copy data source / selection of copy target model

Click the [From] setting item, and select the model name as the data source in the drop-down list.

Click the [To] setting item, and select the model name as the copy target in the drop-down list.

Click [Copy] to execute the copy function. When the pop-up window shows that the model data has been copied, the model data has been copied successfully. After copying is complete, click the title bar to return to the previous menu.

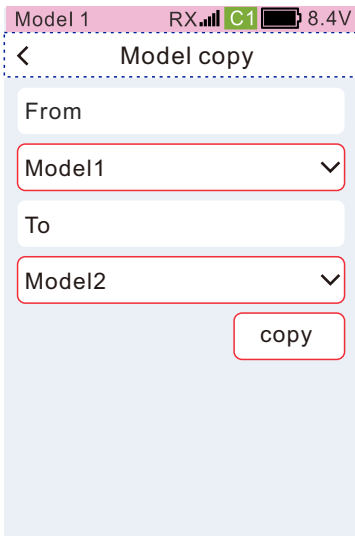

Copy success

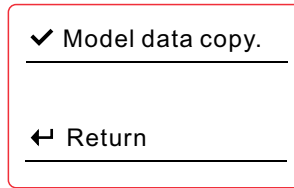

Reset to factory data

Reset the currently selected model parameters, and the reset values are factory settings. (does not affect other model data)

Function path: [Menu]-[Model menu]-[Reset to factory data]

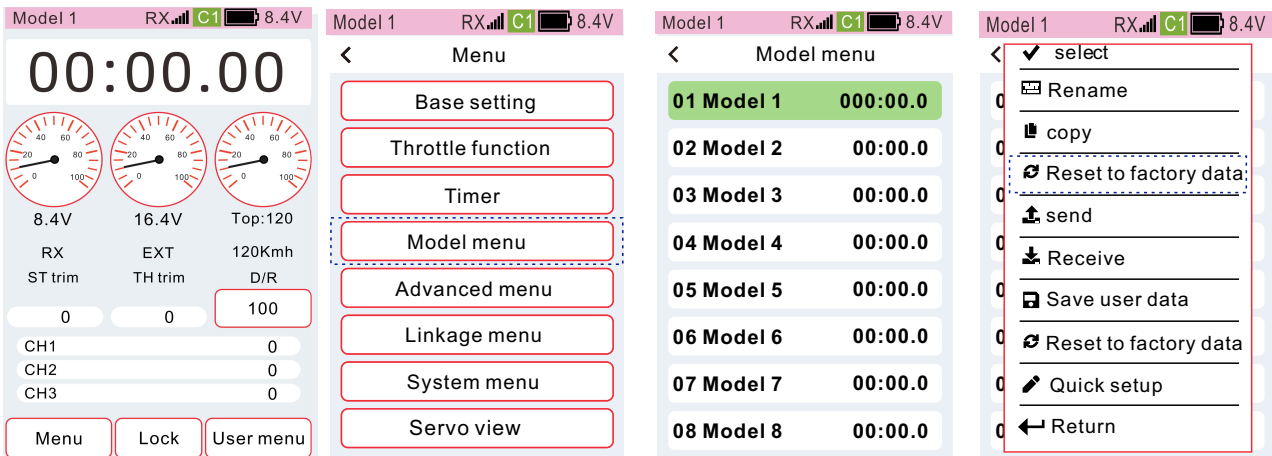

Steps to reset to factory data

Click [Reset to factory data], and click [Yes] in the pop-up window

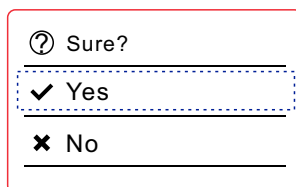

Reset the progress status prompt

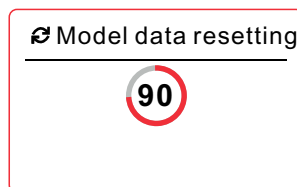

The currently selected model has been successfully reset to factory data, click the title bar to return to the previous interface

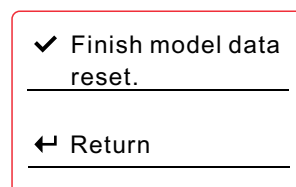

Send/receive

Share selected model data. The selected model data is sent wirelessly to another X9S remote.

Function path: [Menu]-[Model Menu]-[Click the selected model]-[Send]

The location of the selected model is wirelessly used to receive and store model data shared by another X9S remote.

Function path: [Menu]-[Model Menu]-[Click the selected model]-[Receive]

The image illustrates the process of sending and receiving model data through several steps:

- Menu Navigation:** The user starts in the 'Menu' screen, where 'Model menu' is highlighted.
- Model Selection:** In the 'Model menu' screen, '01 Model 1' is selected.
- Send/Receive Action:** A context menu is shown with 'send' and 'Receive' options highlighted.
- Model Data Display:** A large digital display shows '00:00.00'. Below it, three speedometers are shown with values: 8.4V (RX), 16.4V (EXT), and Top:120 (Kmh). Below the speedometers are trim values: ST trim (0), TH trim (0), and D/R (100).
- Confirmation:** A 'Send successful' dialog box is shown with a 'Return' button.
- Physical Buttons:** At the bottom, 'Menu', 'Lock', and 'User menu' buttons are shown.

Tip: To cancel sending/receiving, you can click the [Cancel Send/Receive] button to cancel sending model data.

Save user data

This function can save the currently selected model setting as the user default data. When the model setting is changed or the previous setting data needs to be retrieved, this function can be used to back up the data.

Click [Save user data] to save the latest settings.

Tip: [System menu]-[Factory reset] will not clear the data saved by this function.

Function path: [Menu]-[Model menu]-[Save user data]

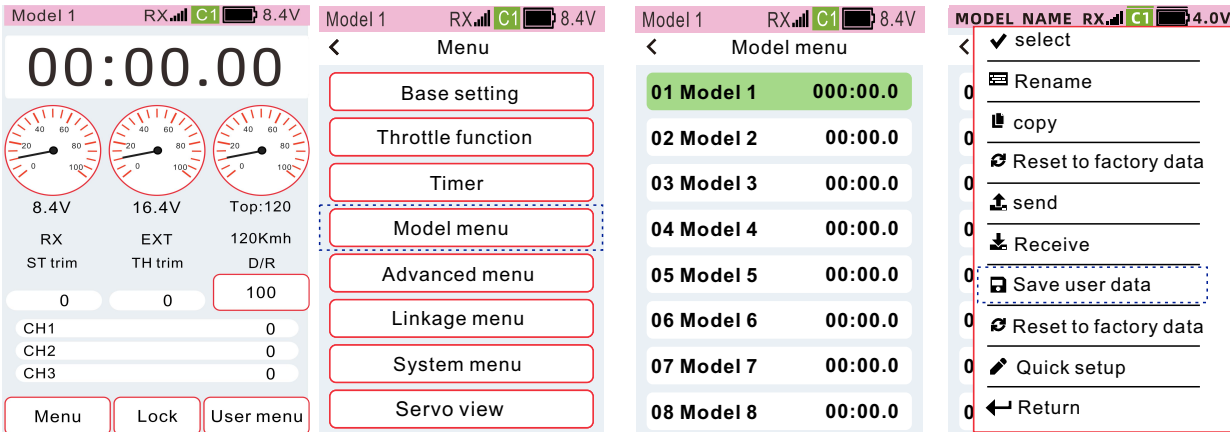

User data saving progress status prompt

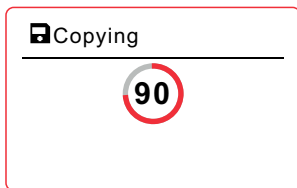

User data has been saved, click the title bar to return to the previous interface

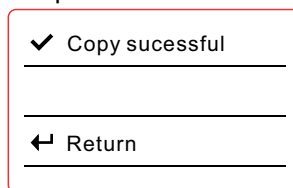

Reset to factory data

Resets the currently selected model parameters to the user default data. (does not affect other model data)

Reminder: When the user has not operated [Save user data], the reset data of [Save user data] and Reset to factory data are the same.

Function path: [Menu]-[Model menu]-[Reset to factory data]

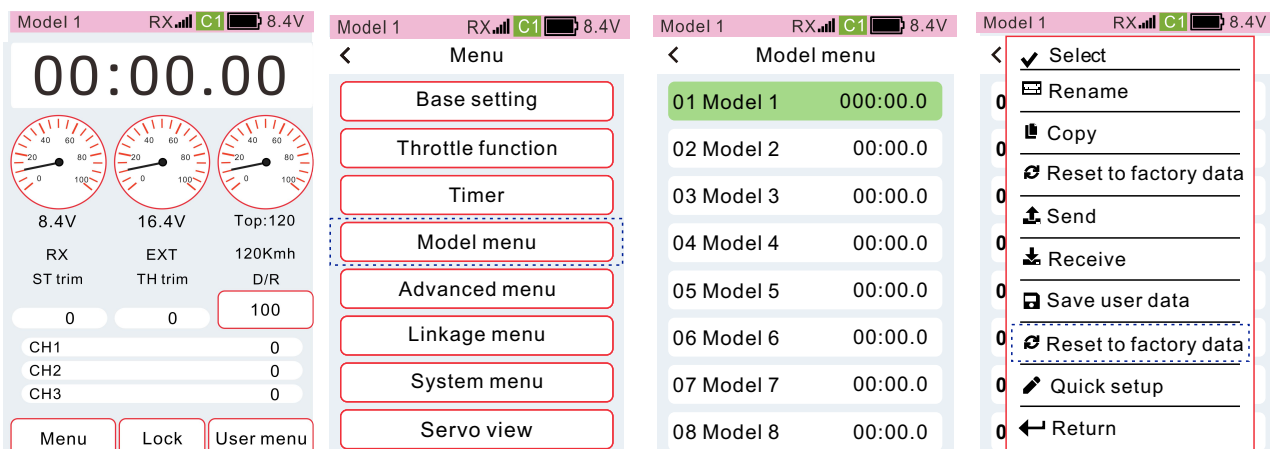

Steps to reset to user data

Click [Reset user data], and click [Yes] in the pop-up window

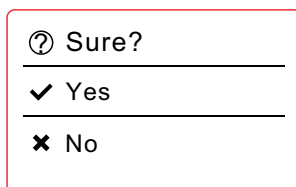

Reset progress status prompt

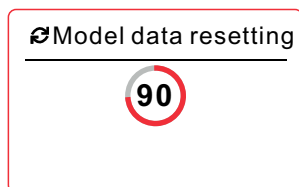

The currently selected model has been successfully reset to factoryDefault data, click the title bar to return to the previous interface

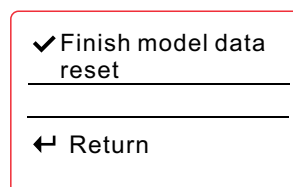

Quick setup

The X9S transmitter features a quick setup function that allows for various settings and easy operation when setting up a new model.

After starting the [Quick setup], click [Yes] to quickly set the functions in the following order, and click the title bar to return to the previous step.

[Select model type]→[Channel setting]→[Link]→[Servo type]→[Channel reverse]→[End point]→[Sub trim]

Function path: [Menu]-[Model menu]-[Quick setup]

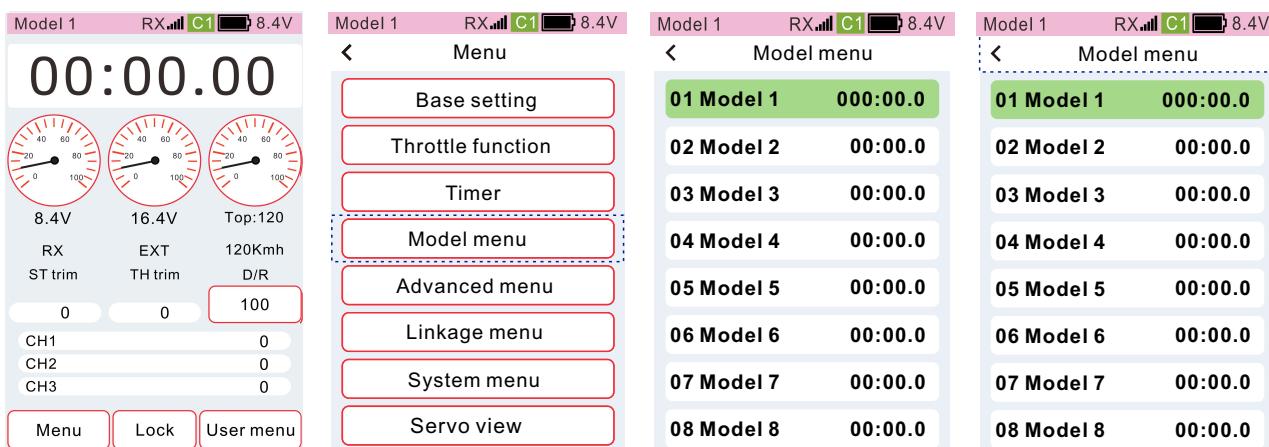

Function steps: [Quick Setup]→[Channel setting]→[Link]

Quick Setup: Choose from 8 model types, each type of model data has default channel function presets.

Select the model type: EP Car Standard, EP Car(LED Unit), GP Car Standard, Crawler 4WS/MOA, Boat(Single engine), Boat(Dual engine), Tank, Motorcycle.

Channel settings: You can customize the settings, the operation functions and triggering methods of the wheel, trigger, trim, buttons, knobs, and rocker switches.

Channel function: 1. DT1, DT2, DT3, VR, DL, can be set, ratio channel, step fine-tuning, function ratio, function channel ratio. 2. PS1, PS2, PS3, SW1, SW2, can be set, channel, function (on/off), function mode switch.

Step direction: 1. Wheel, trigger, VR, can be set, positive and negative output. 2. DT1, DT2, DT3, DL, can be set, trim the step amount, positive and negative output. 3. PS1, PS2, PS3, SW1, SW2, can be set (normal/triggered) mode. The switch supports (normal/trigger) mode when selecting (CH set) in [Channel setting], and only supports (trigger) mode when selecting (CH set) in [Channel setting].

Position setting: 1. The steering, trigger, and position setting only support the use of [Timer] and [Model Timer]. Set (set the trigger area), positive and negative (set the positive and negative of the trigger area), mode [Linear/Symmetric] trigger mode. 2. SW1, SW2, can set switch trigger mode, switch off, switch off, switch off, switch on, switch on, switch on, switch on.

Link: long press SET key to flash orange light when receiving power. Telemetry (off) after receiving the code does not send back, receive the power supply voltage, external power battery voltage.

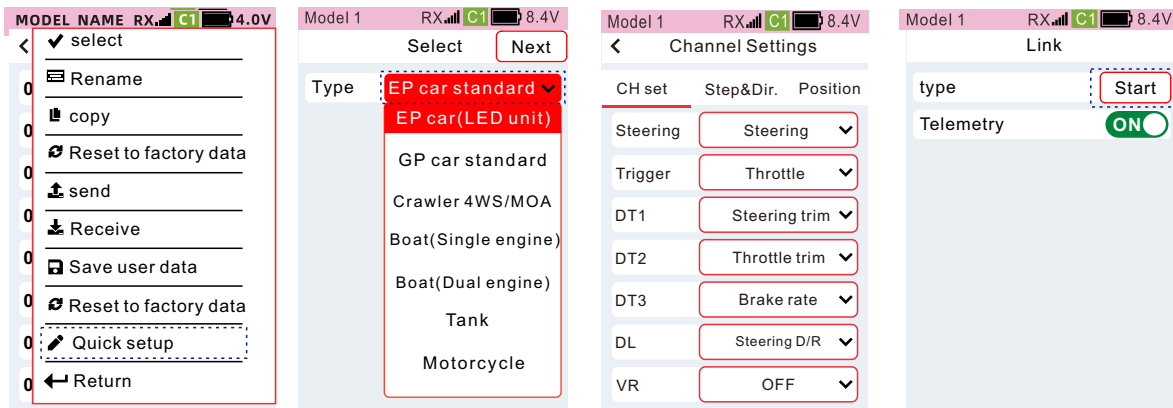

Function steps: **【Servo type】** → **【Channel reverse】** → **【End point】** → **【Sub trim】**

Servo type: [Normal servo] mode, supported (Normal servo/digital servo), [Digital servo] mode, not supported (Normal servo).

Reminder: In the digital servo mode, use the Normal servo "will burn the servo". Digital servo mode, use digital servo "response speed improvement".

Positive and negative settings: You can set the channel forward and reverse. Program mixing, tank mixing, adjustable positive and negative ratios to set output positive and negative.

Note: Setting the steering gear channel will change the midpoint of the steering gear arm, so the pull rod of the steering gear arm should be removed to prevent the steering gear from being pulled.

End point: [End point] can set the channel output size. High priority will affect the itinerary associated with the channel. [Channel limit] can limit the output size of the channel. High priority, limiting the channel mixing stroke, and the output ratio superposition exceeds the set value.

Sub trim: You can set the center point of the channel to keep the left and right strokes of the channel consistent.

Reminder: First adjust the midpoint of the steering gear, and then adjust the left and right levers.

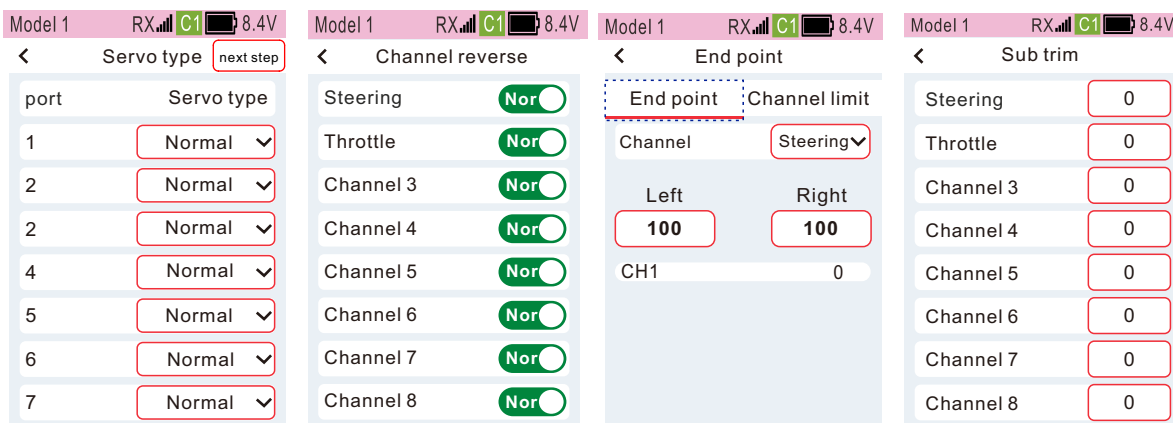

Before using the model equipment, the F/S data should be set as required.

There are three modes of fail-safe protection, F/S, hold, close.

(F/S) mode: When the receiver cannot receive the transmitter signal, the receiver outputs the preset parameter position and keeps the position.

Reminder: If it is an oil-powered model, for the sake of safety, it is recommended to set this runaway protection mode, and the throttle channel is set to brake action.

(Hold) mode: When the receiver cannot receive the transmitter signal, keep the position before the receiver cannot receive the signal. **(OFF) mode:** When the receiver cannot receive the transmitter signal, the receiver signal stops the signal output, and the servo is in a free movement state at this time.

Fail safe protection setting: After the transmitter is set to complete the runaway data, click the title bar to return to the previous menu, send data from the transmitter to the receiver, the purple light of the receiver flashes, and the green light is always on, the receiver saves the data.

Reminder: The fail-safe protection data is saved by the receiver, and it can be set successfully only when the transmitter and receiver are connected. For safety, the model equipment should be fixed during setting to avoid safety accidents.

Advanced menu

Channel Setting

This function can set the operation function and trigger mode of the wheel, trigger, trim, key, encoder, knob, and 3-speed switch.

Reminder: Please refer to page (62-63) for the name and position of the switch.

Wheel and trigger: You can set the forward and reverse of the stepping direction, timer, model timing, trigger mode, and trigger forward and reverse.

DT1, DT2, DT3, DL: Function, step, direction can be set.

VR: Functions and directions can be set.

PS1, PS2, PS3: function and trigger mode can be set

SW1, SW2: function, trigger mode, gear can be set

Function path: [Menu]-[Advanced menu]-[Channel setting]

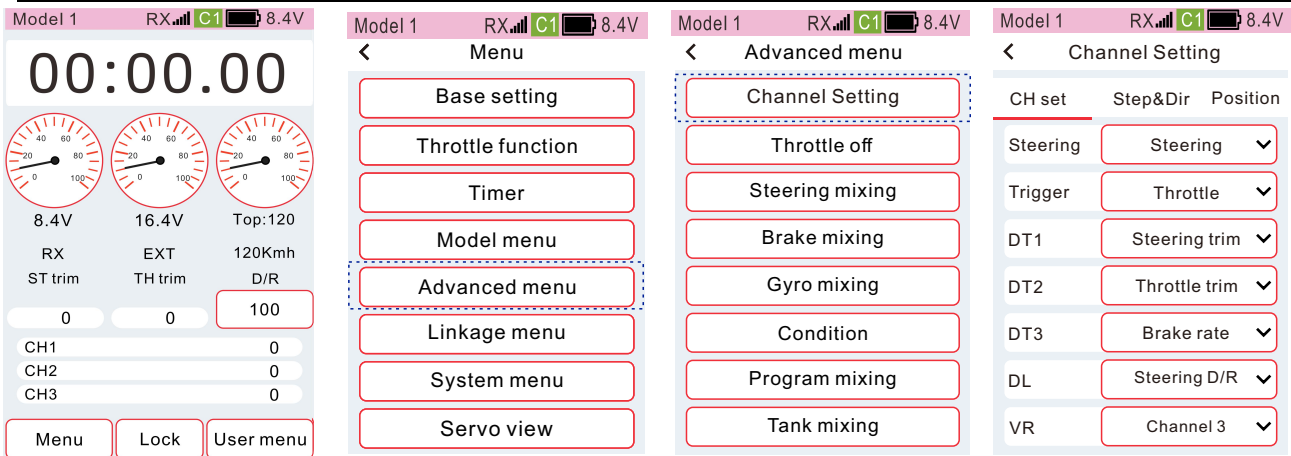

How to set the trim and knob [Function]

Click to select the trim or knob (DT1, DT2, DT3, DL, VR) In the drop-down function list, select the desired function.

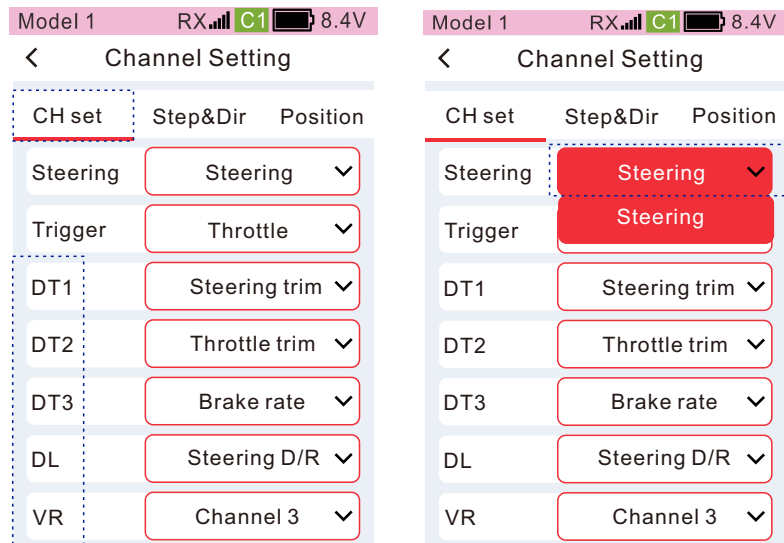

How to set trim, knob step, and direction

Click the [Step&Dir.] button

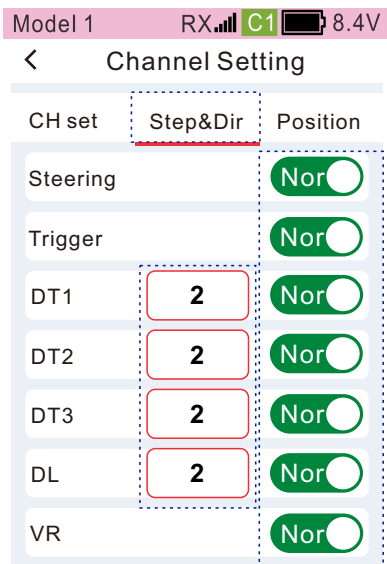

Setting method of trim and knob 【Step&Dir.】

Click the DT1, DT2, DT3, DL step value setting box, the focus display is the theme color (the default theme is red), [-][Reset][+] is displayed at the bottom of the screen. Click or long press **[-]** **[+]** to adjust the step value.

Description: Step, trim or knob operation, the output value each time.

How to set trim and knob 【Direction】

ClickDt1、Dt2、Dt3、DI、Vr Nor or Rev to set the trim adjustment, the positive or negative direction of the knob.

When displayed as Nor it means that the trim and knob output is positive.

When it is displayed as Rev it means that the trim and knob output are reversed.

Note: The selectable functions of the trim and knob are as follows:

How to set the trigger and wheel 【Position】

Click on [Setting]

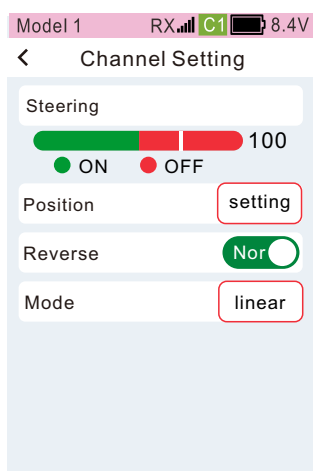
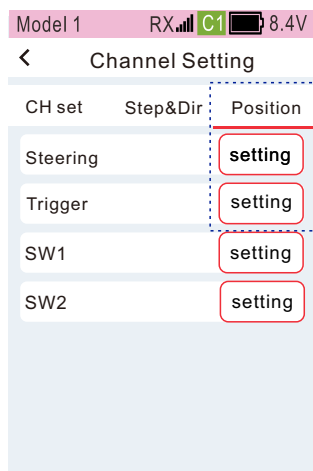

The white slider on the indicator bar: Indicates the current trigger or wheel position. Position: Set the position of the [On] and [Off] areas, and click the [Set] button to obtain the current trigger or wheel position. ON: When the reel or trigger position is in this area, the status is [ON]. OFF: When the reel or trigger position is in this area, the state is [OFF]. Positive and negative: orient the [ON] and [OFF] areas.

Mode Linear: The trigger position of the indicator bar is divided into two areas: [On] and [Off]. Symmetrical: The trigger position of the indicator bar is divided into 3 areas: [On] [Off] [On] or [Off] [On] [Off]. And the [On] or [Off] area is symmetrical.

Physical input	Function Selection	Function description
DT1	OFF	Unassigned function
DT 2	Steering D/R	【Dual rate】 Steering channel-rate
DT2	Brake rate	【Dual rate】 Throttle channel-rate
VR	Speed-Steering turn speed	【Speed-】 Steering channel-foward speed rate
DL	Speed-Steering return speed	【Speed-】 Steering channel-return speed rate
	Speed-THR turn speed	【Speed-】 Throttle channel-foward speed rate
	Speed-THR return speed	【Speed-】 Throttle channel-return speed rate
	Steering index-Steering	【Steering Curve】 Steering channel index-index、VTR-rate , no function while EXP
	Forward curve	【Foward curve】 Throttle channel index-index、 index-index , VTR-rate,no function while EXP
	Brake curve	【Brake curve】 Throttle channel index-brake、 index-index,VTR-rate , no function while EXP
	A.B.S (return brake)	A.B.S return brake rate
	A.B.S delay	A.B.S delay rate
	A.B.S cycle	A.B.S cycle rate
	Steering trim	Steering trim
	Throttle trim	Throttle trim
	Trim 3	CH3 trim
	Trim 4	Ch4 trim
	Trim 5	Ch5 trim
	Trim 6	Ch6 trim
	Trim 7	Ch7 trim
	Trim 8	Ch8 trim
	Trim 9	Ch9 trim
	Channel 3	Channel3 input,left input minimum(reverse),right input maximun(Normal)
	Channel 4	Channel4 input,left input minimum(reverse),right input maximun(Normal)
	Channel 5	Channel5 input,left input minimum(reverse),right input maximun(Normal)
	Channel 6	Channel6 input,left input minimum(reverse),right input maximun(Normal)
	Channel 7	Channel7 input,left input minimum(reverse),right input maximun(Normal)
	Channel 8	Channel8 input,left input minimum(reverse),right input maximun(Normal)
	Channel 9	Channel9 input,left input minimum(reverse),right input maximun(Normal)
	Sub trim 1	Sub trim channel1,left input reverse,right input normal
	Sub trim 2	Sub trim channel2,left input reverse,right input normal
	Sub trim 3	Sub trim channel3,left input reverse,right input normal
	Sub trim 4	Sub trim channel4,left input reverse,right input normal
	Sub trim 5	Sub trim channel5,left input reverse,right input normal
	Sub trim 6	Sub trim channel6,left input reverse,right input normal
	Sub trim 7	Sub trim channel7,left input reverse,right input normal
	Sub trim 8	Sub trim channel8,left input reverse,right input normal

	Sub trim 9	Sub trim channel8,left input reverse,right input normal
	Throttle idling - rate	Throttle idling - rate
	Throttle off	Engine flameout. - rate
	Brake mix-CH3	Brake mix-CH3 rate
	Brake mixi-CH4	Brake mix-CH4 rate
	4WS mixing-rate	4WS mixing-rate
	Ackermann-rate	Ackermann-rate
	Dual ESC rate-rate	Dual ESC- rate
	Gyro gain-rate	Gyro gain-rate

Button, 3-step switch [Function] setting method

Click the selection button or 3-position switch (PS1, PS2, PS3, SW1, Sw2)

Select a desired function from the drop-down list

From the drop-down function list, select the desired function

Click the [Step&Dir] button

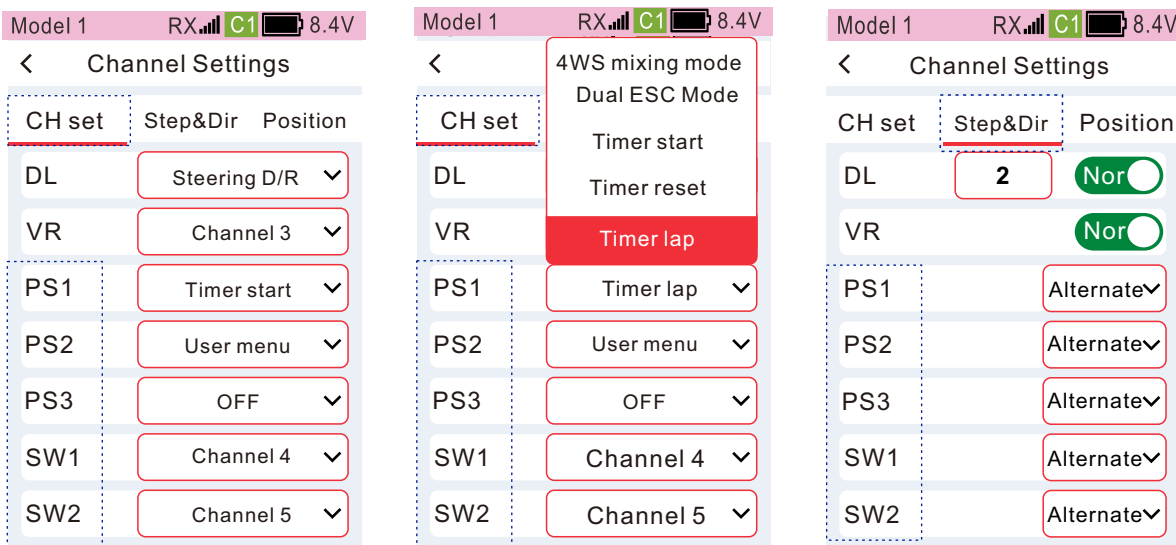

Click PS1, PS2, Ps3

Trigger: Each time it is pressed, the state is switched once.

Normal: Switch state when pressed, keep current state when released.

WS1, WS2

Trigger: When the switch position is [ON], the state will be switched once, and when the switch position is [OFF], the state will not be switched.

Normal: When the switch position is [ON], the state is switched, and when the switch position is [OFF], the current state is maintained.

The setting method of the 3-position switch

Position] Click [Setting]

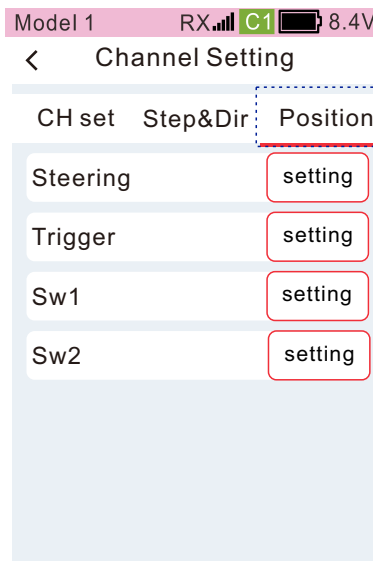

Click the WS1 or WS2 [Settings] button

Schematic: real-time indication of the current switch position.

Up: Set the state when the switch position is up

Middle: Set the state when the switch position is in the middle

Down: Set the state when the switch position is down

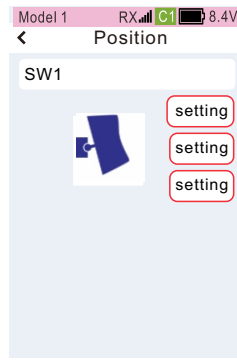

Tip: No matter which setting combination, keep at least one [On] and one [Off] state. For example, when the user sets the upper and middle positions as [On], the lower position is set from [Off] to [On], and the system will automatically set the status of the upper and middle positions to [Off].

Note: The selectable functions of buttons and 3-position switch are as follows:

Physical input	Function Selection	Function declaration	Default value
SW1	OFF	Unassigned function	Nor
SW2	Servo view	Press to jump to the servo view interface	Nor
	Telemetry voice	State ON/OFF	Nor
	A.B.S	State ON/OFF	Nor
	Throttle idle-state	State ON/OFF	Nor
	Program mix 1	State ON/OFF	Nor
	Program mix 2	State ON/OFF	Nor
	Program mix 3	State ON/OFF	Nor
	Program mix 4	State ON/OFF	Nor
	Program mix 5	State ON/OFF	Nor
	Throttle off	State ON/OFF	Nor
	Channel 3	Channel input, first click output minimum value	Nor
	Channel 4	Channel input, first click output minimum value	Nor
	Channel 5	Channel input, first click output minimum value	Nor
	Channel 6	Channel input, first click output minimum value	Nor
	Channel 7	Channel input, first click output minimum value	Nor
	Channel 8	Channel input, first click output minimum value	Nor
	Channel 9	Channel input, first click output minimum value	Nor
	Gyro	Mode, AVCS and general switching	Alternate
	4WS-mode	Mode switching	Alternate
	Dual ESC-mode	Dual ESC switching	Alternate
	Timer - Start	Long press to jump directly to the timer interface, short press to start, and then pause	Alternate
	Timer - reset	Short press the timer to reset	Alternate
	Timer-lap timer	Short press to time one lap	Alternate
	Condition	Short press to switch condition 1 and Condition 2	Nor
	User menu	Press to go to the user menu	Alternate
	Tank mixing-steering	Short press toggle tank mixed control -forward and reverse	Nor
	Tank mixing-throttle	Short press toggle tank mix control - throttle forward and reverse	Nor
	Trainer	Trainer on or off	Nor

Physical input	Function select	Function declaration	Default
PS1	OFF	Unassigned function	Nor
PS2	Servo view	Press to jump to the servo view interface	Nor
PS3	Telemetry voice	State ON/OFF	Nor
	A.B.S	State ON/OFF	Nor
	Throttle idle-state	State ON/OFF	Nor
	Program mix1	State ON/OFF	Nor
	Program mix2	State ON/OFF	Nor
	Program mix3	State ON/OFF	Nor
	Program mix4	State ON/OFF	Nor
	Program mix5	State ON/OFF	Nor
	Throttle off	State ON/OFF	Nor
	Channel 3	Channel input, first click output minimum value	Nor
	Channel 4	Channel input, first click output minimum value	Nor
	Channel 5	Channel input, first click output minimum value	Nor
	Channel 6	Channel input, first click output minimum value	Nor
	Channel 7	Channel input, first click output minimum value	Nor
	Channel 8	Channel input, first click output minimum value	Nor
	Channel 9	Channel input, first click output minimum value	Nor
	Gyro	Mode, AVCS and general switching	Alternate
	4WS-mode	Mode switching	Alternate
	Dual ESC-mode	Dual ESC switching	Alternate
	Timer - Start	Long press to jump directly to the timer interface, short press to start, and then pause	Alternate
	Timer - reset	Short press the timer to reset	Alternate
	Timer-lap timer	Short press to time one lap	Nor
	Condition	Short press to switch condition 1 and Condition 2	Alternate
	User menu	Press to go to the user menu	Nor
	Tank mixing-steering	Short press toggle tank mixed control -forward and reverse	Nor
	Tank mixing-throttle	Short press toggle tank mix control - throttle forward and reverse	Nor
	Trainer	Trainer on or off	Nor

Throttle off

When using this function, the [Throttle off] control switch must be set in [Advanced menu] - [Channel setting] - [CH1 set]. Use the switch to fix the throttle servo output at the set position. Engine flameout provides a safe and easy way to stop the engine running. Generally, it can be achieved by flipping the control switch at idle speed. The flameout position must be set.

Function path: [Menu] - [Advanced menu] - [Throttle off]

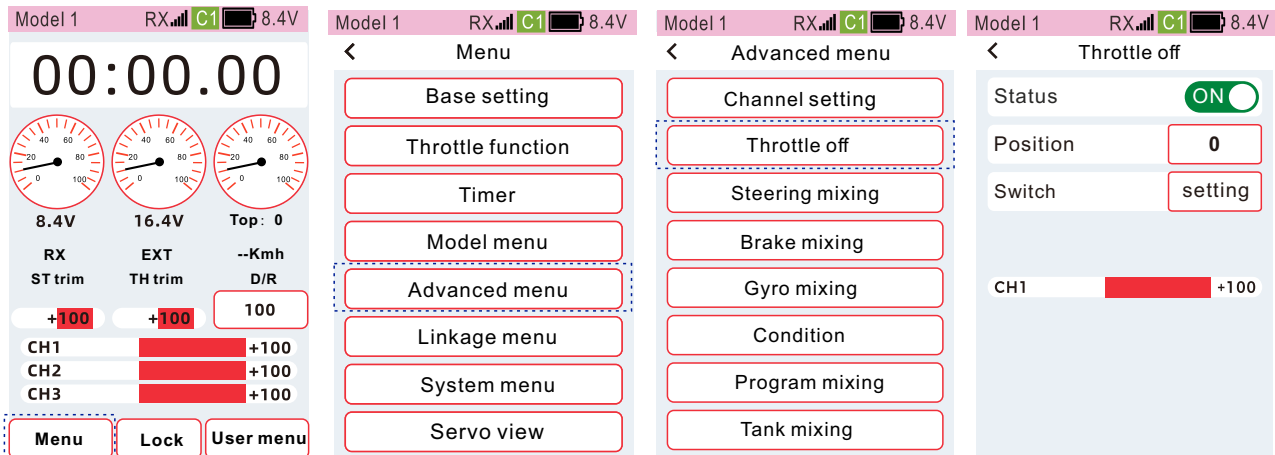



Tip: When [Throttle off] - [THR Mode] is set to [F100: B0]; [F50: B50] is set as the brake output, because there is no brake function. Regardless of the setting value of [Position], the output is the output of the throttle channel when the throttle channel is at the neutral point. It is necessary to adjust the position of engine flameout through the stroke amount in [Base setting] [End point] [End point] and the trim amount in [Trim setting].

How to set throttle off

When the status is set to [On], the function is enabled, and when it is set to [Off], the flameout engine is not enabled.

Switch selection: DT1, DT2, DT3, DL, VR, PS1, PS2, PS3, SW1, Sw2 can choose to control the switch

-  : Indicates that the state is on
-  : Indicates the state is off

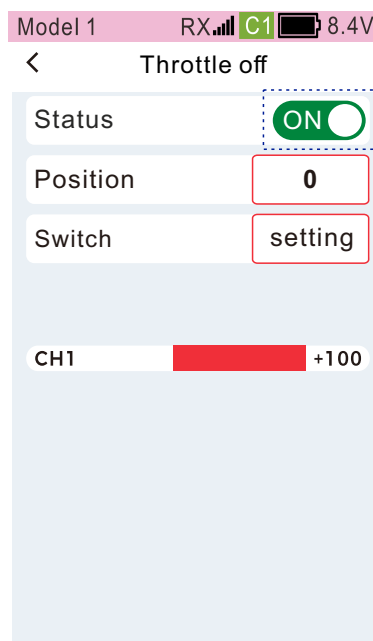

* If the model is an electric device, the engine flameout function can also be achieved by using [Throttle off].

Setting method of throttle off [Position] [Switch]

•Click [Position], the focus display is the theme color (the default theme is red), and the bottom of the screen displays [-] [Reset] [+].

•Click or long press **[-]** **[+]** to adjust the position value.

Switch selection, click to enter [Switch], you can assign PS1, PS2, PS3, SW1, SW2, as the control switch

•After the setting is completed, click the title bar to return to the previous menu .

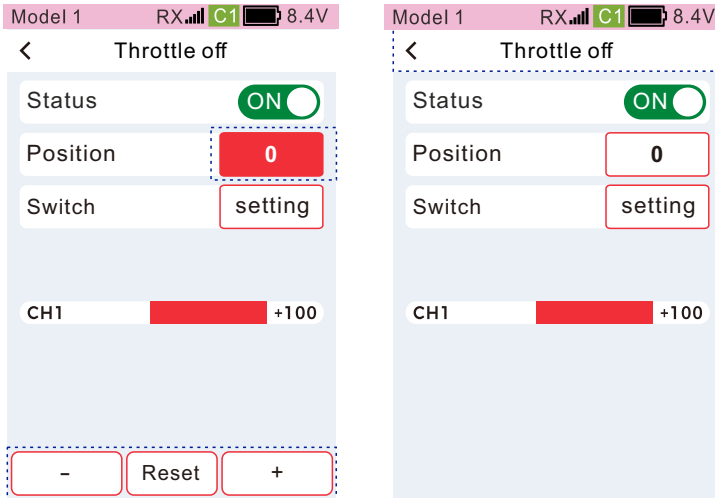

Steering Mixing

This function is a mixed control function that uses 2 channels to control the left and right steering respectively. The left and right ratios can be set independently to achieve smooth turning. Steering 1 is connected to channel 1 servo, and steering 2 is connected to channel 4 servo. After adjusting the left and right ratios, the steering angle can also be adjusted by adjusting the ratio of the steering angle. The ratio of steering angle can be set as the input of [Steering Mixing-Ackermann] through [Advanced menu]-[Channel setting]-[CH set].

Function path: [Menu]-[Advanced menu]-[Steering mixing].

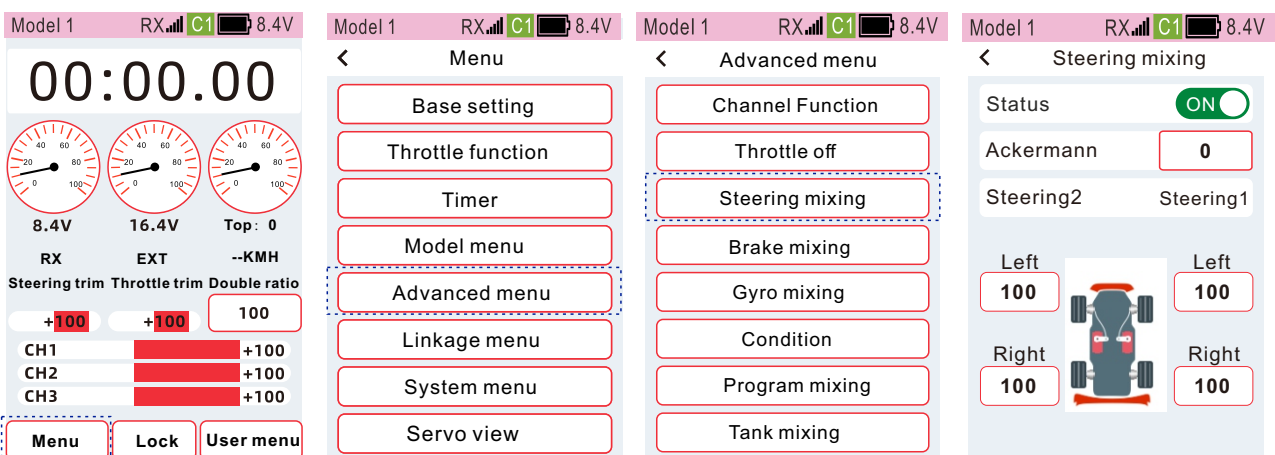

Note: After the steering mixing function is enabled, channel 4 is only used as the output of steering mixing direction 2, and the channel 4 function setting in [Channel Setting] will be invalid.

Tip: The functions of [Steering mixing] and [Dual ESC] can only be turned on by selecting 1 from 2. When the [Dual ESC] function is turned on, click the [Steering mixing] function status on/off, there will be The following pop-up window reminds:

Note:

【Dual ESC】 function turned on, please turn off before using this function

Back

Note:

【Brake mixing 4CH】 is enabled, please turn off before using this function

Back

Steering Mixing

When the status is set to [ON], the function is enabled, and when it is set to [OFF], the steering mixing control function is not enabled.

 : Indicates that the state is on

 : Indicates the state is off

Steering 1, Steering 2 Adjust the left and right ratios.

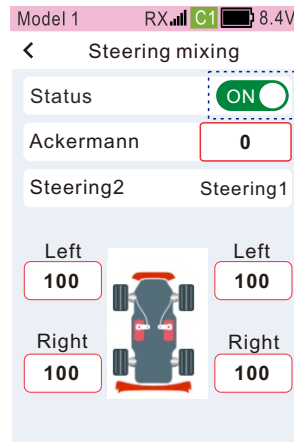

- Click left or right, the focus is displayed as the theme color (the default theme is red), and the bottom of the screen displays [-] [Reset] [+].
- Click or long press **[-]** **[+]** to adjust the ratio.
- After the setting is completed, click the title bar to return to the previous menu .

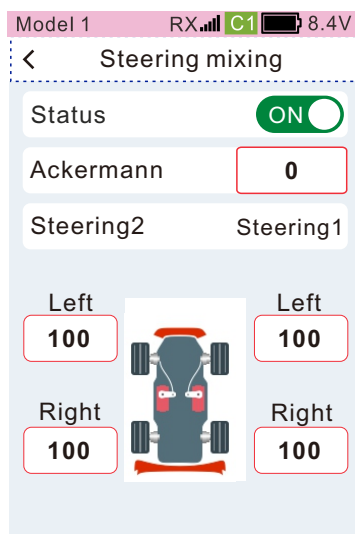
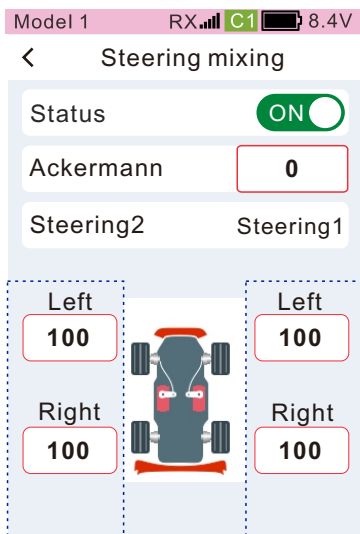

* The default stroke up and down is 100. Adjusting the parameter value will change the size of the steering stroke. The current window only affects the output of the [steering mixing control] function.

Brake mixing

This function can be used when the brakes of the front and rear wheels of the model must be controlled and adjusted separately.

This function provides 3 control methods.

- The throttle channel controls the rear wheel brake, and channel 3 or channel 4 controls the front wheel brake.
- The throttle channel controls the rear wheel brake, and the channel 3 and channel 4 control the front wheel brake.
- The throttle channel controls the acceleration independently, not the brake. Channel 3 and Channel 4 control the front and rear wheel brakes. When the accelerator channel is braking, the braking action is mixed to channel 3 and channel 4 in proportion.

Tip: When [Throttle function] [THR mode] is set to [Forward 100: Brake 0], since there is no output at the brake end, there will actually be no output after this function is set, so when using this function, it is necessary to set the [Accelerator Mode] Set to [Forward 50: Brake 50] or [Forward 70: Brake 30].

Note: After the brake mixing function is enabled, when channel 3 or channel 4 is enabled, the function settings of channel 3 and channel 4 in [Advanced Function]-[Channel Setting] will be invalid.

Function path: [Menu]-[Advanced menu]-[Brake mixing]

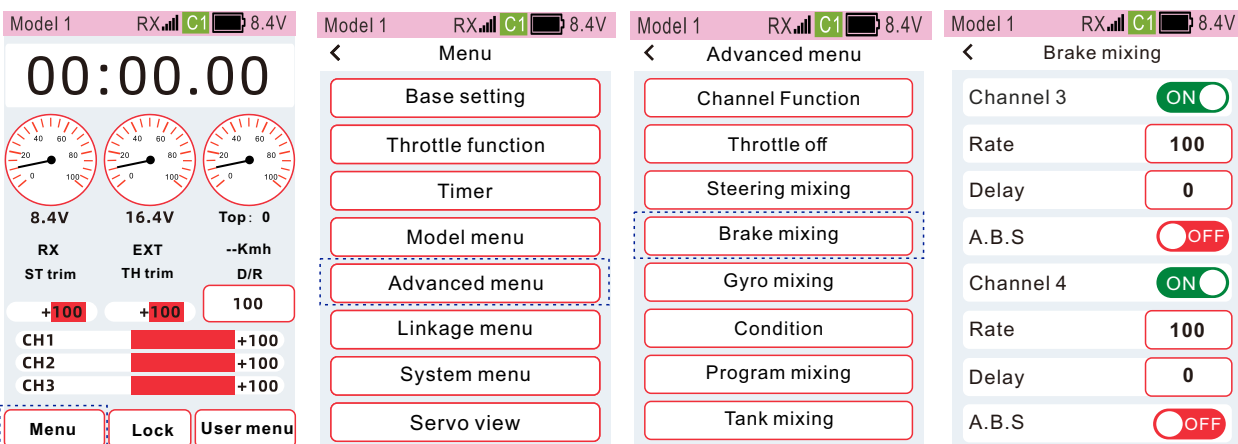

How to set the status of channel 3 and channel 4

Channel 3/Channel 4: When the status is [On], it will control the front wheel brake, and when the status is [Off], it will not be used to control the front wheel brake.

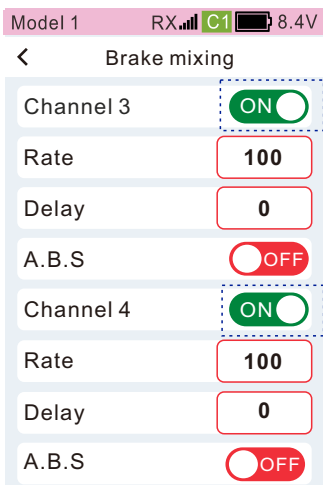

Note:

【Dual ESC】function turned on, please turn off before using this function

Back

Note:

【Brake mixing 4CH】is enabled, please turn off before using this function

Back

*Note: After the brake mixing function is enabled, the output channel of the brake is enabled in channel 4, and the function setting of channel 4 in [Channel Settings] will be invalid.

Tip: When the [Brake mixing control] function is turned on, enable channel 4, click [Steering mixing control] and [Dual ESC] function state is turned on/off, there will be a pop-up window on the top right to remind as shown above.

ON : Indicates that the state is on

OFF : Indicates the state is off

How to set the ratio of channel 3 and channel 4

Ratio: The brake action is mixed to channel 3/channel 4, and the action amount ratio is set to 0: the brake action is 0% mixed to channel 3 and channel 4, that is, channel 3 and channel 4 do not act. Ratio set to 100: 100% brake action mixed to channel 3 and channel 4.

- Click [Ratio], the focus is displayed as the theme color (the default theme is red), and the bottom of the screen displays [-] [Reset] [+].

- Click or long press[-][+]to adjust the position value.

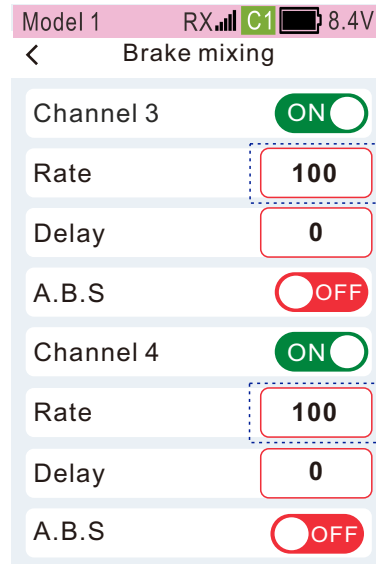

Channel 3, Channel 4 delay setting method

Delay: Adjust the speed of the brake execution of channel 3 and channel 4. When set to 0: Fastest, no delay. When set to 100: slowest speed and maximum delay.

- Click [Delay], the focus display will be the theme color (the default theme is red), and the bottom of the screen will display [-] [Reset][+]•Click or long press[-][+] to adjust the position value.

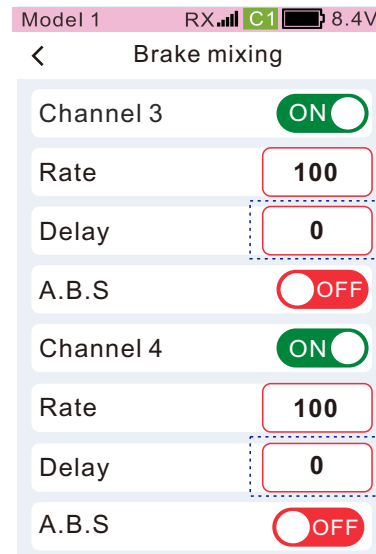

How to set A.B.S status

A.B.S: Action mixing with A.B.S brake Set to channel 3 and channel 4 to [On], and mix the action with A.B.S brake to channel 3 and channel 4. Set to [Off], do not mix A.B.S brake action, just mix common brake action to channel 3 and channel 4.

- The setting is completed, click the title bar to return to the previous menu

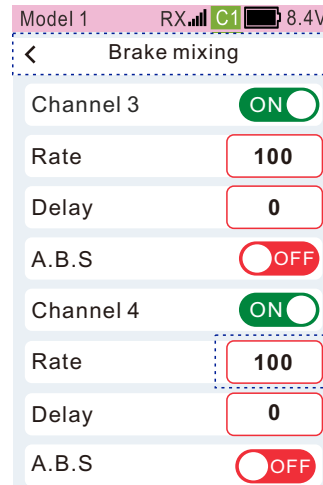
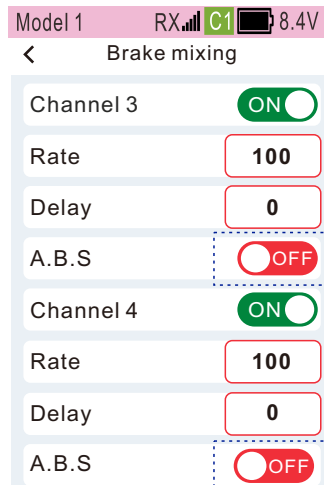

Gyro mixing

This function can set the sensitivity of the gyroscope, which can be divided into built-in gyroscope and external gyroscope, and can set the gyroscope sensitivity value, mode, sensitivity switch, and output channel.

It is used for the compensation and correction of the tail attitude of the model when the model is turning, and the compensation and correction of the direction and attitude of the model when driving in a straight line.

Function path: [Menu]-[Advanced menu]-[Gyro mixing]

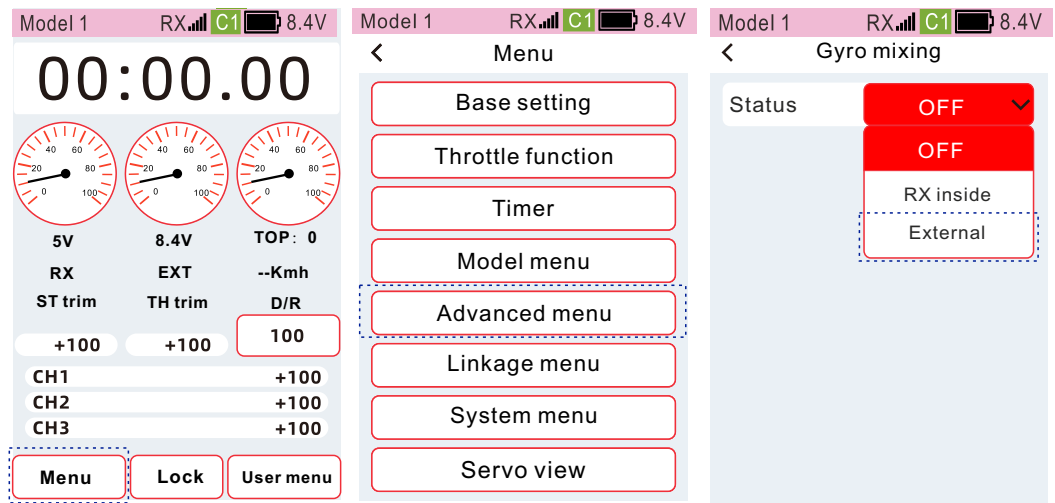

Gyroscope: If you have a gyroscope, you only need the knob to adjust the sensitivity function, and you can assign the gyroscope interface channel in the channel function, DL, VR.

- ① Click the item (Gain), the setting value will be displayed in red, and the bottom of the screen will display **[-] [Reset] [+]**.
- ② Click or long press **[-] [+]** to set the value and adjust the sensitivity of the gyroscope.

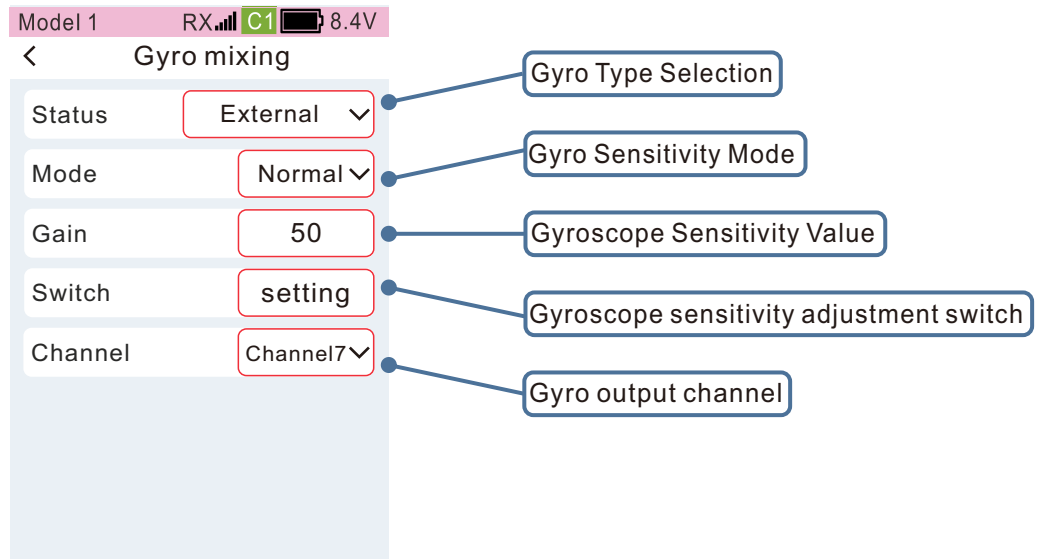

Condition

After the condition mode function is turned on, the [Dual rate] [Speed] [Curve] [trim Setting] function in one model data can set two sets of data.

For example, under the general condition (condition mode 1), the dual rate-direction is set to 90%; the second condition (condition mode 2), the dual rate-direction is set to 80%.

Tip: When set to ON, the function condition mode function is enabled. When set to OFF, the data of Condition 1 and Condition 2 are the same when switching modes.

- When using the conditional mode, you must set the switch (set in [Advanced menu]-[Channel setting]-[CH set]) to switch between the conditional mode 1 and the conditional mode 2.
- After switching the mode, the speaker voice broadcasts the current conditional mode status, conditional mode 1, conditional mode 2, and displays the current conditional mode in the status bar.

DT1: Condition Mode 1

DT2: Condition Mode 2

Function path: [Menu]-[Advanced menu]-[Condition]

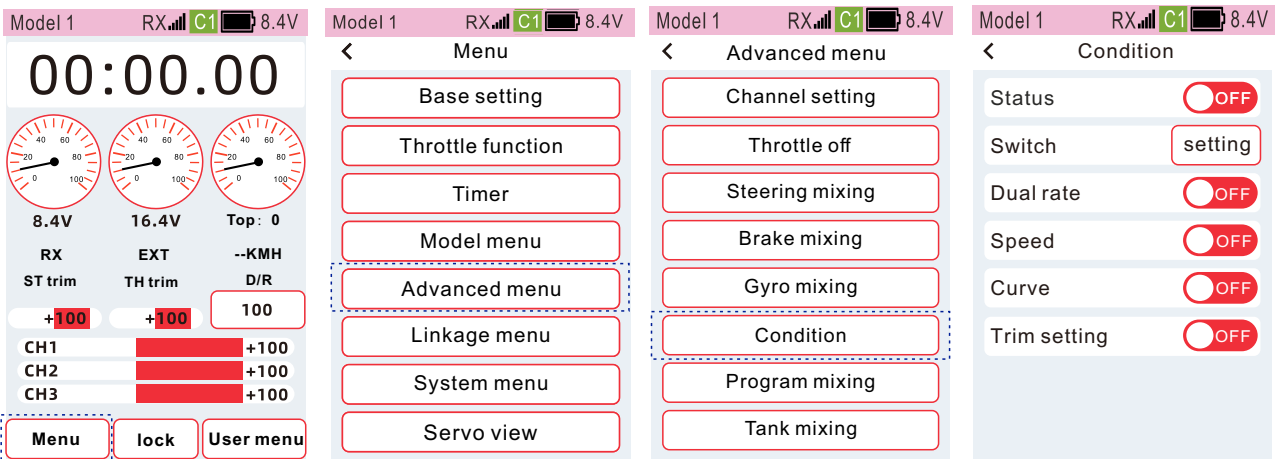

How to Set the Condition Mode Status

When the status is set to [On], the function is enabled, and when it is set to [Off], the function is not enabled.

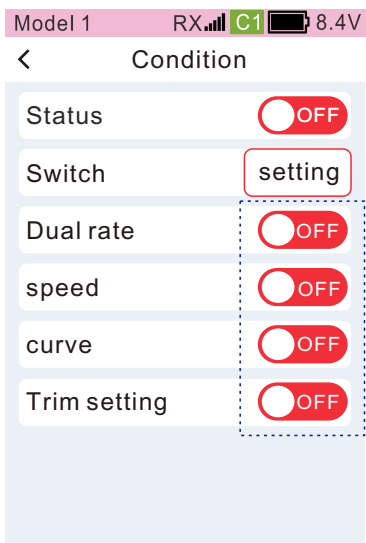

Dual rate: When the status is ON, the [Dual rate] function enables the conditional mode, and the conditional mode 1 and conditional mode 2 ratios can be set independently.

Speed: When the status is ON, the [Dual rate] function enables the conditional mode, and the conditional mode 1 and conditional mode 2 ratios can be set independently.

Curve: When the status is ON, the [Dual rate] function enables the conditional mode, and the conditional mode 1 and conditional mode 2 ratios can be set independently.

Trim: When the status is ON, the [Dual Rate] function enables the conditional mode, and the conditional mode 1 and conditional mode 2 ratios can be set independently.

Switch selection: optional control switches PS1, PS2, PS3, SW1, Sw2.

Base setting: Enter the corresponding function, switch through the condition mode switch, and set the condition 1 condition 2 data independently.

: Indicates the status is on

: Indicates the status is off

Program mixing

The actions of the throttle, direction, channel 3 and channel 4 can be arbitrarily mixed. 5 mixing combinations can be created, and free mixing such as channel selection or switch knob can be customized, and the direction of the mixing ratio can be set separately.

Function path: [Menu]-[Advanced menu]-[Program mixing]

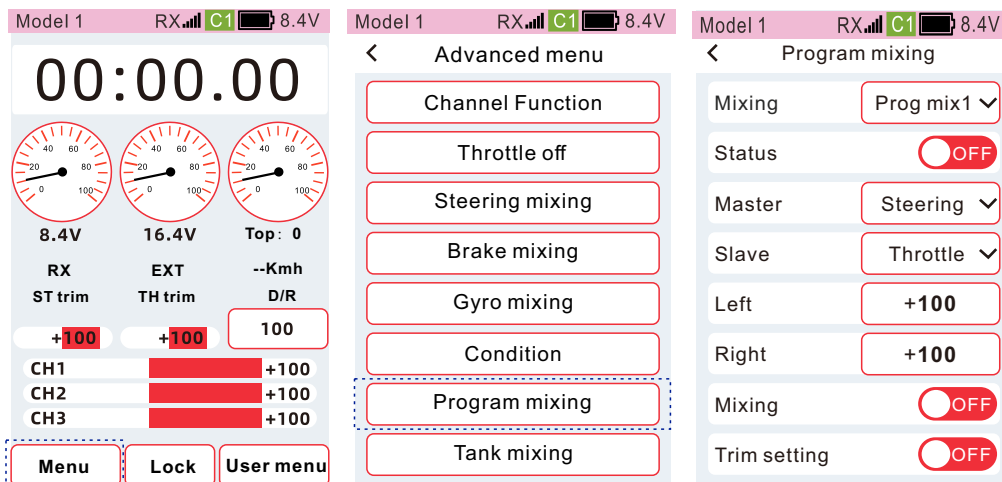

Mixing: Program Mix1 to Program Mix5

Master: Select the input channel of the mix.

Slave: Select the output channel of the mix. The action of the main channel is mixed to the sub channel.

Left Rate: The mixing ratio of the negative side. Mixing output range: -120% ~ +120%.

Right Rate: The mixing ratio of the positive side. Mixing output range: -120% ~ +120%.

Mixing: You can choose whether some settings of the input channel are mixed to the output channel.

Trim: You can select whether the trim amount of the input channel is mixed to the output channel. You can choose whether the trim amount of the main channel will mix the sub channel.

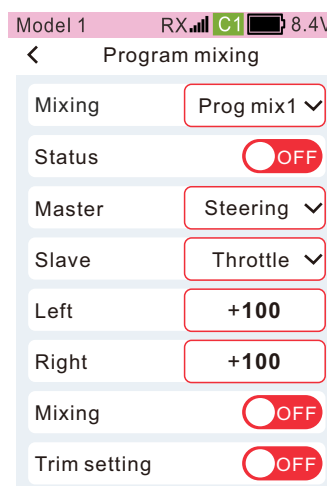

Selection method of program mixing group 1 to group 5

Click the mixing control setting item, and select the desired programming mixing control serial number in the drop-down list.

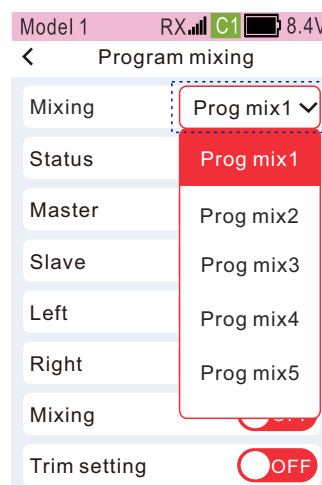

The setting method of programming mixing [Status], [Mixing], [Trim]

When the status is set to [On], the function is enabled, and when it is set to [Off], the function is not enabled.

: Indicates that the state is on

: Indicates the state is off

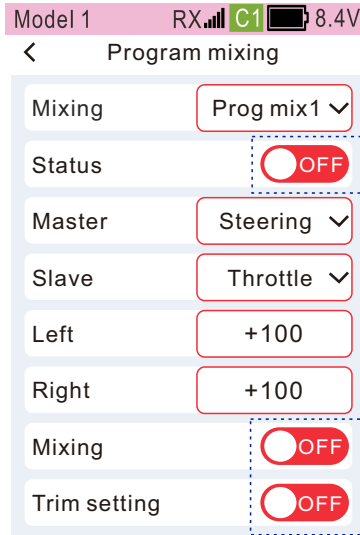

Channel setting method of master and slave

Click the setting item of Master and Slave, and select the desired channel in the drop-down list.

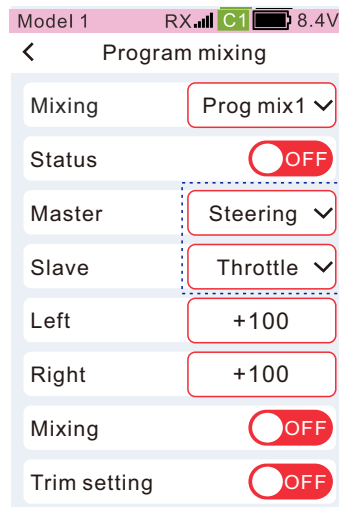

How to set the left and right ratio

- Click [Left], [Right] ratio, the focus is displayed as the theme color (the default theme is red), and the bottom of the screen displays [-] [Reset] [+].
- Click or long press [-] [+], Adjust the position value.
- After the setting is completed, click the title bar to return to the previous menu.

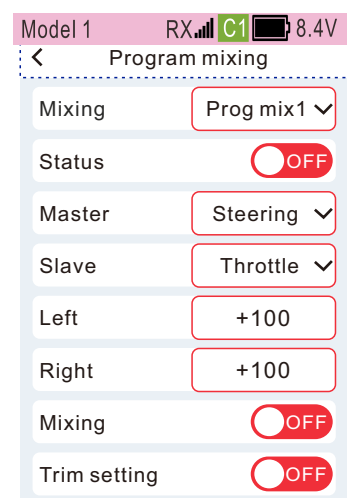
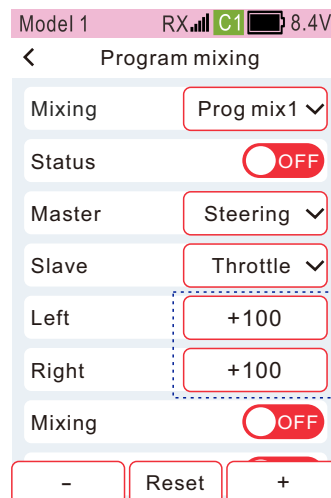

The following are the functions of each channel as the main channel(Master), When mixing is selected, the main channel will be mixed to the sub channel(Slave):

When the direction is the main channel:

Rudder angle setting (direction), speed (direction), dual ratio (direction), curve (direction), four-wheel steering will be mixed to any secondary channel.

When the throttle is the main channel:

Rudder angle setting (throttle), speed (throttle), throttle mode, throttle braking amount, throttle idle speed, A.B.S, curve (throttle), dual electronic governor, engine shutdown will be mixed to any secondary channel .

When channel 3 is the main channel:

Rudder angle setting (channel 3), four-wheel steering, and brake mixing will be mixed to any sub channel.

When channel 4 is the main channel:

Rudder angle setting (channel 4), brake mixing, and dual electronic governors will be mixed to any secondary channel.

When channel 5 to channel 9 are main channels:

The rudder angle setting (channel 5 to channel 9) will be mixed to any sub channel.

Tank Mixing

This function is used for mixed control of tracked vehicles such as tanks, and models of dual-engine driven robots. Through the mixing control of the direction channel and the throttle channel, when the trigger or the runner is operated, the steering can be realized in place, and the forward and reverse are synchronized.

Function path: [Menu]-[Advanced menu]-[Tank Mixing]

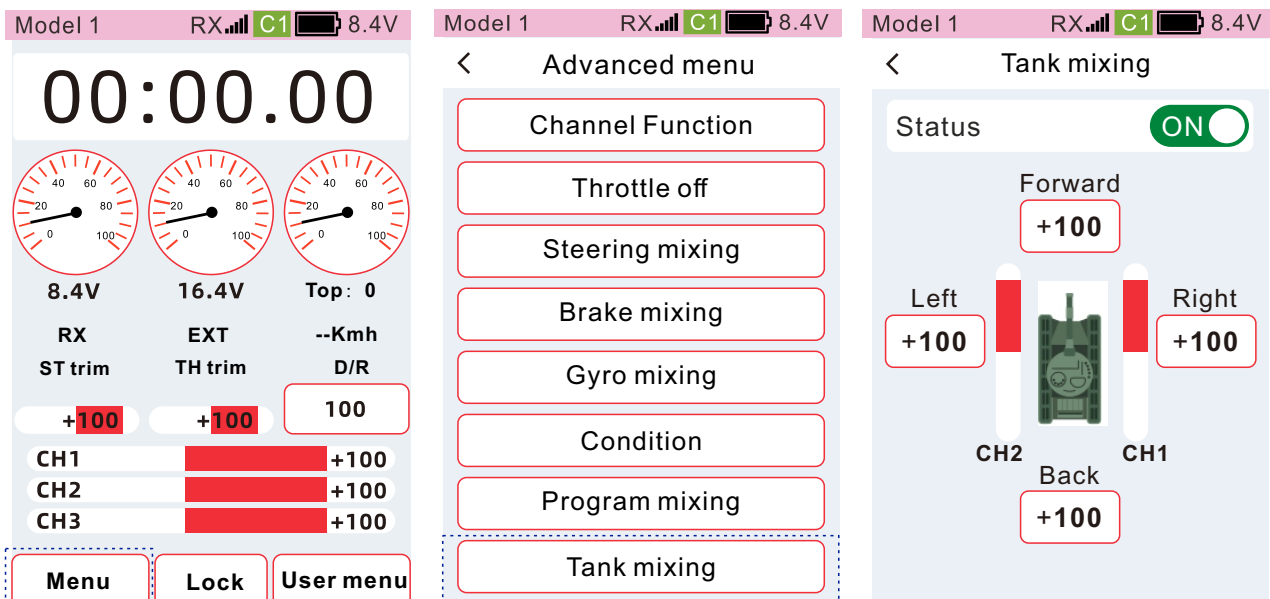

When operating the trigger:

The direction channel and the throttle channel are output at the same time to realize the forward and steering functions.

When operating the runner:

Differential output of the direction channel and the accelerator channel to realize the steering function.

When the trigger and wheel are operated simultaneously:

When the trigger is in the forward position, the runner is operated to the right, and the model car is turned to the front right at the ratio of [forward] and [right turn].

When the trigger is in the forward position, the wheel is operated to the left, and the model car is turned to the left front at the ratio of [forward] and [left].

When the trigger is at the brake position, the runner is operated to the right, and the model car turns to the right and rear at the ratio of [Back] and [Right].

When the trigger is at the brake position, the wheel is operated to the left, and the model car is turned to the left rear at the ratio of [Back] and [Left].

Tank mixing state setting method

When the status is set to [On], the function is enabled, and when it is set to [Off], the function is not enabled.

Note: The numerical value is adjusted, the speed of the crawler engine driving, positive and negative value adjustment, the crawler engine drive is forward and reverse.

: Indicates that the state is on

: Indicates the state is off

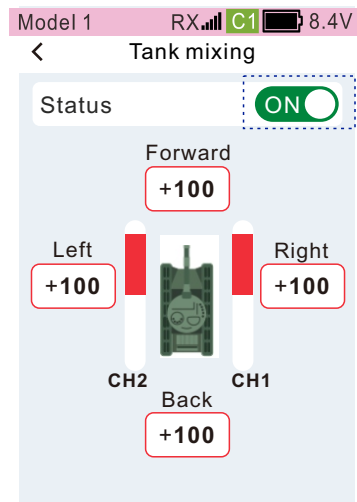

Tank mixing rate setting method

●Click [Left], [Right], [Forward] or [Back], the focus display will be the theme color (the default theme is red), and the bottom of the screen will display [-][Reset] [+].

●Click or long press[-][+]to adjust the ratio.

●After the setting is completed, click the title bar to return to the previous menu .

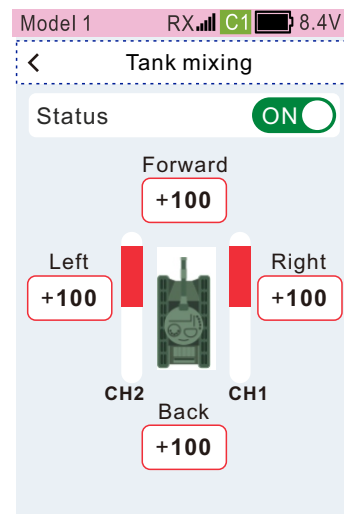
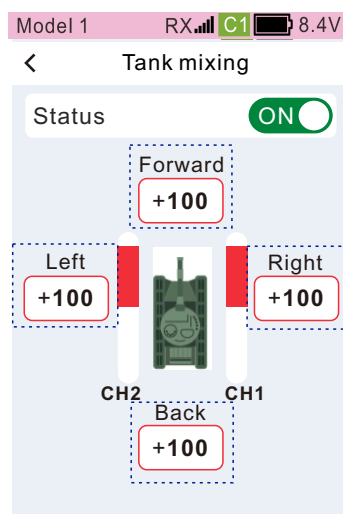

Dual ESC

Throttle channel action is mixed to allow channel 4 to control front-wheel drive.

Status: Set the on/off of the [Dual ESC] function.

Mixing

When the mixing control is turned on, the speed (throttle), throttle mode, curve (throttle), throttle idle, A.B.S, and brake volume settings will be mixed to channel 4.

Mixing is off, the above function settings will not be mixed to channel 4.

Trim

When the trim mode is turned on, the auxiliary trim and trim settings of the throttle channel will be mixed to channel 4.

Trim is off, the above function settings will not be mixed to channel 4.

Rate

Mix the action of the throttle channel to channel 4 according to the set ratio.

Rate 0: Throttle channel action is not mixed to channel 4.

Rate 1~100: Throttle channel action 1~100% mixed to channel 4.

The dual ESC has three mixing modes:

Front Wheel Drive: The front wheels are driven, the rear wheels do not move.

Four-wheel drive: Front and rear wheels are driven at the same time.

Rear-wheel drive: The front wheels do not move, the rear wheels are driven.

Function path: [Advanced menu] - [Dual ESC]

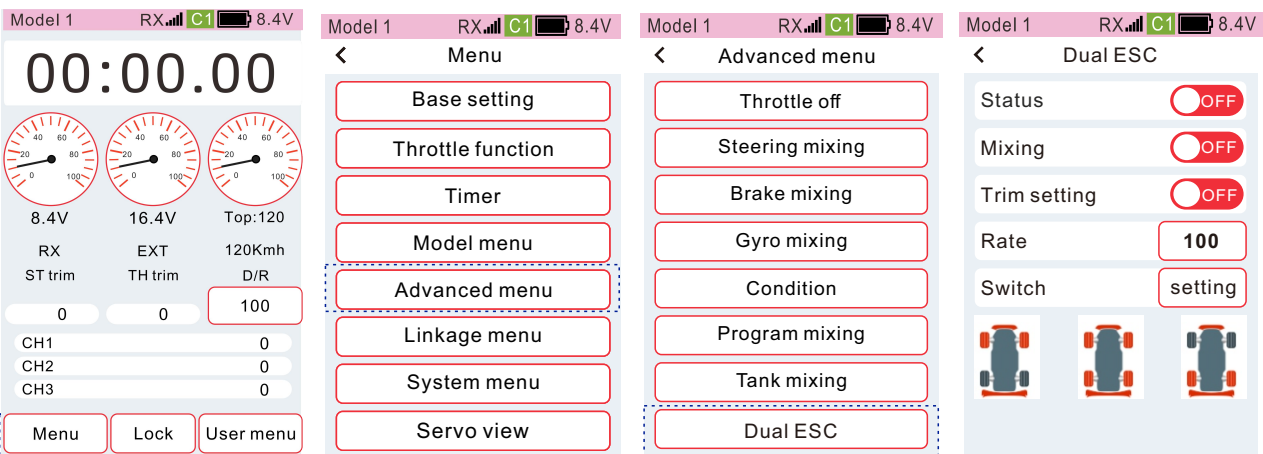

Note: After the dual ESC function is turned on, channel 4 is only used as the output of ESC 2, and the channel 4 function setting in Channel Settings will be invalid.

Tip: The function of [Steering mixing] and [Dual ESC] can only be turned on 1 of 2. When the function [Dual ESC] is turned on, click the function state of [Steering mixing] is turned on/off, or the function state of [Brake mixing] is turned on/off, and the pop-up window will be reminded as shown in the following picture:

Note:

【Dual ESC】function turned on, please turn off before using this function

Back

Note:

【Brake mixing 4CH】is enabled, please turn off before using this function

Back

【Status】 【Mixing】 【Trim】 setting method of dual electronic governor(Dual ESC)

When the status is set to [ON], the function is enabled, and when it is set to [OFF], the function is not enabled.

Status: Set the ON/OFF of the [Dual ESC] function.

 ON: Indicates that the state is on

 OFF: Indicates the state is off

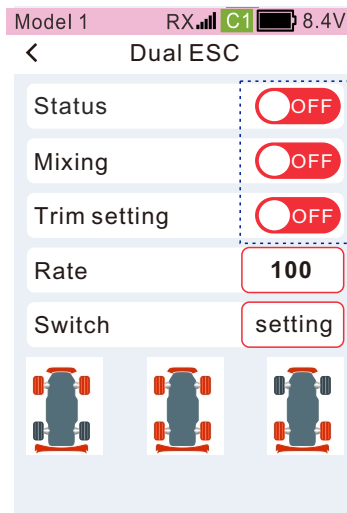

Rate setting method of Dual ESC

- Click the [Rate] setting box, the focus display will be the theme color (the default theme is red), and the bottom of the screen will display [-] [Reset] [+].

- Click or long press [-] [+] to adjust the ratio.

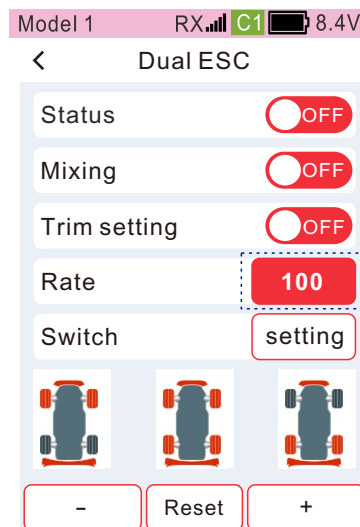

4WS mixing

The action of the directional channel is mixed to make channel 3 control the rear wheel steering.

Status: Set the on/off of the [Dual Electronic Governor] function.

Mode: Select the mode of [Four Wheel Steering], and share three modes: [Mode 2], [Mode 3], and [Mode 4]. The front wheels steer, the front wheels steer, the rear wheels do not move.

Reverse control, the front wheel turns and the rear wheel turns in the opposite direction of the front wheel. In the same direction control, the front wheel turns and the rear wheel turns in the same direction as the front wheel.

The rear wheels steer, the front wheels do not move, and the rear wheels steer.

Rate:

Mix the action of the direction channel to channel 3 at the set ratio.

Ratio 0: Direction channel action is not mixed to channel 3.

The ratio is 1~100: the direction channel action 1~100% is mixed to channel 3.

Mixing:

When mixing is on, the speed (direction), dual ratio (direction), and curve (direction) settings will be mixed to channel 3.

Mixing off, speed (steering), dual rate (steering), curve (steering) settings will not be mixed to channel 3.

Switch selection: optional control switches PS1, PS2, PS3, SW1, Sw2.

Function path: [Advanced menu] - [4WS mixing]

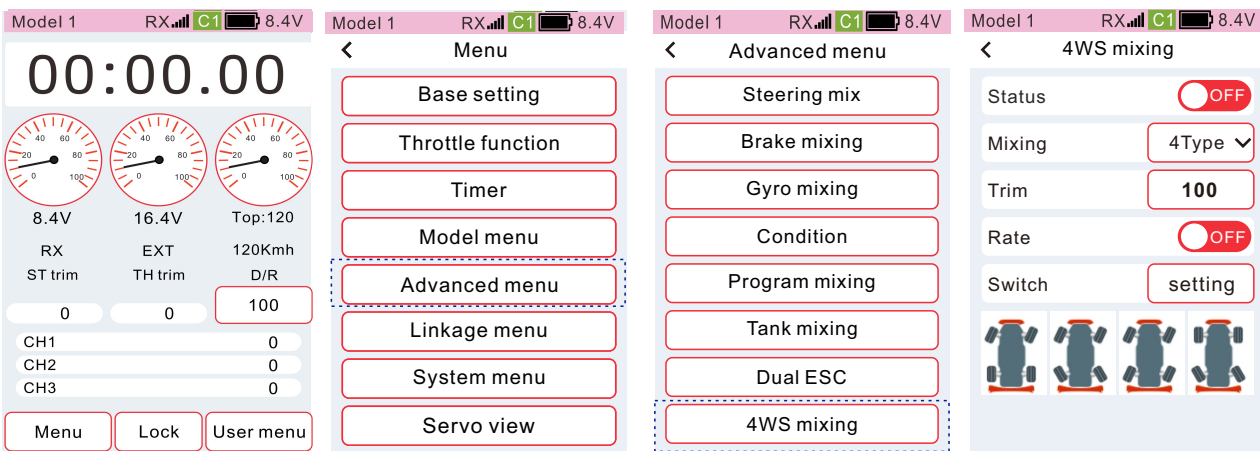

Four-wheel steering [Status] [Mixing] [Mode] setting method

When the status is set to [ON], the function is enabled, and when it is set to [OFF], the function is not enabled.

Click the mode setting box and select the desired mode from the drop-down list.

 ON: Indicates that the state is on

 OFF: Indicates that the state is off

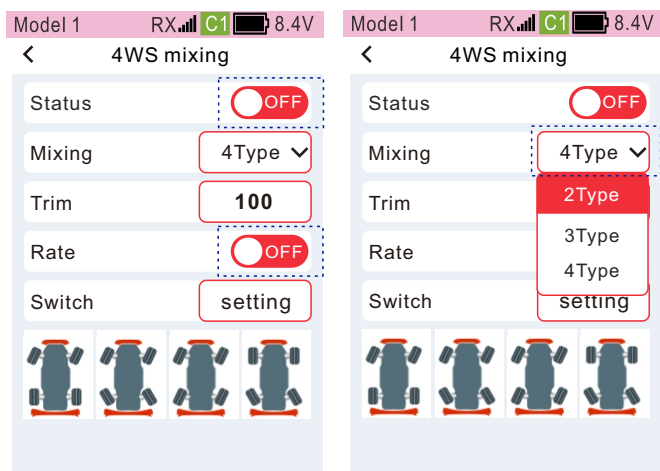

4WS mixing [Rate] setting method:

- Click [Rate], the setting value will be focused and displayed as the theme color (the default theme is red), and the bottom of the screen will display [-] [Reset] [+].
- Click or long press [-] [+] to adjust the rate.

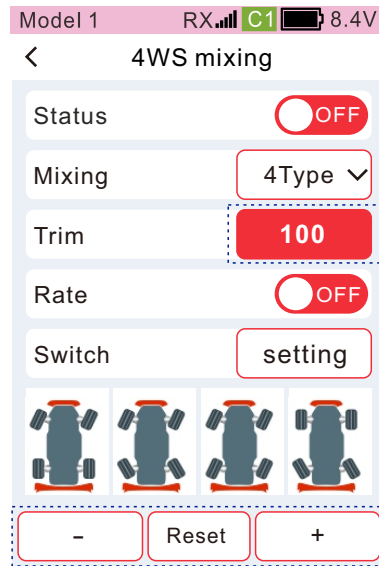

Linkage menu

Servo view

This function can understand the servo output of each channel and confirm the servo action.

Function path: [Menu] - [Linkage menu] - [Servo view]

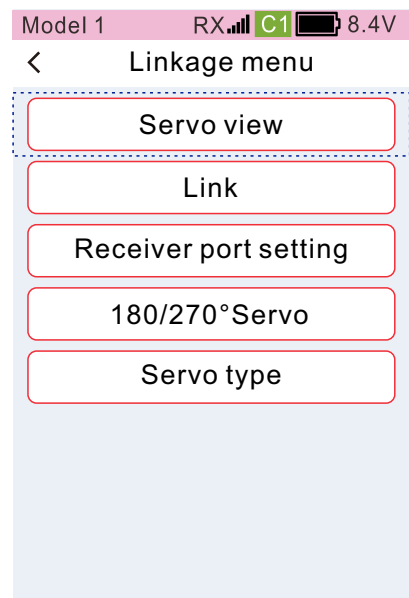
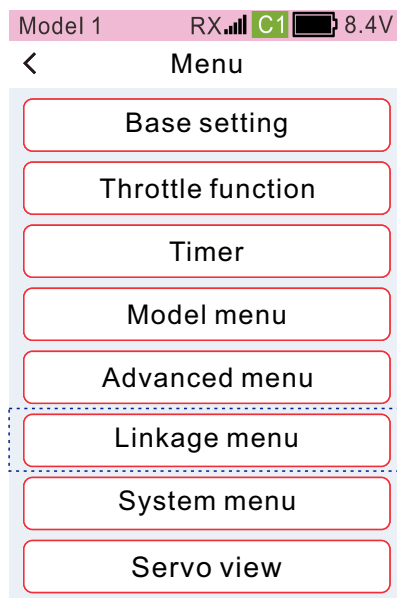
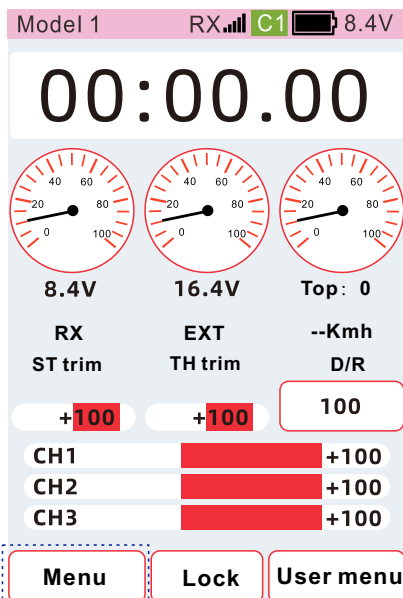

1. When operating the channel such as the steering wheel or the throttle trigger, the action range of the servo can be confirmed according to the output position of the indicator bar.
2. Confirm the completion, and click the status bar to return to the previous level.

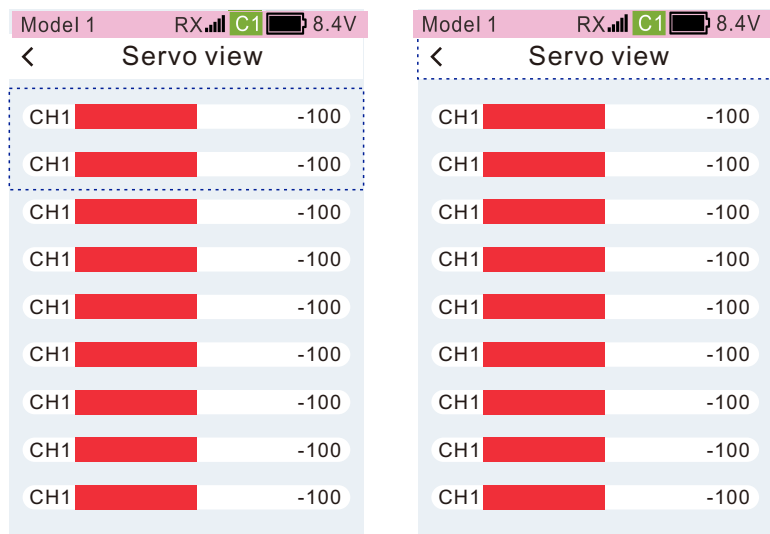

Link

The link/bind/code matching function is used to match the transmitter and receiver.

Telemetry: data return function. It is mainly used for function judgment and data analysis. Closing it will affect the use of security functions. It is enabled by default, and it is recommended to enable it.

Function path: [Menu]-[Linkage menu]-[Link]

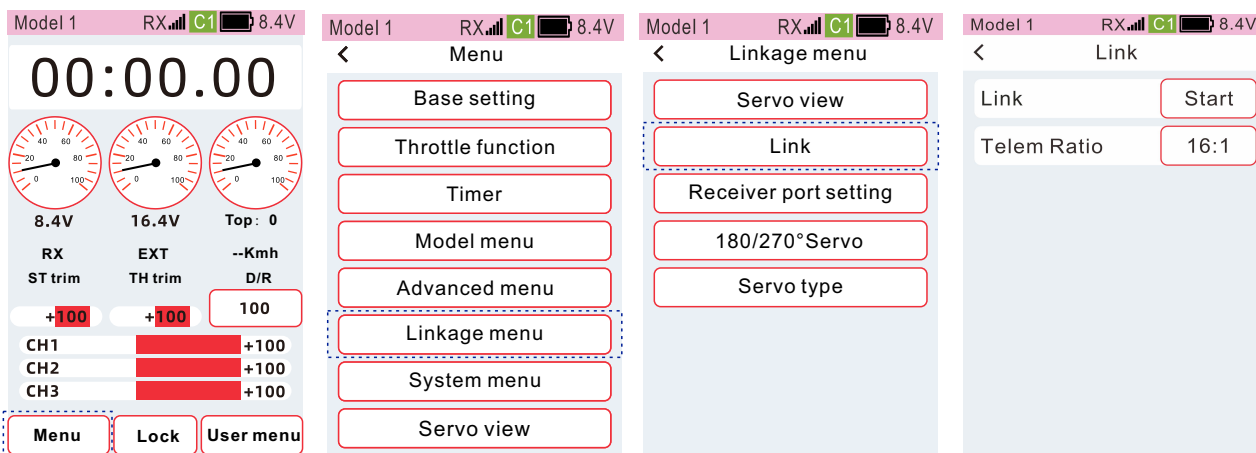

How to link

Transmitter: Click the start button to enter the code matching state

Receiver: Power on, press and hold the [SET] key for 3 seconds, the LED orange light flashes.

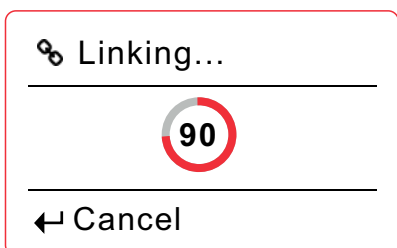

Authentication method:

Successful link: the receiver LED light turns solid (PWW mode: purple, W.BUS mode: green, PPM mode: blue)

Connect to the servo: operate the corresponding channel of the transmitter, if the servo has a synchronous action, the link is successful.

Notice:

- The distance between transmitter and receiver is less than 1 meter.
- The transmitter cannot be paired in the simulator and student modes. The mode modification path: [Menu]-[System setting]-[Trainer and Simulator]
- There is no other WFLY 2.4G system with the same protocol in the vicinity, and the code matching operation is being carried out
- During the linking process, if you want to exit, click [Cancel].

Warning: When operating the link, please be careful not to connect the power equipment, and pay attention to the danger of sudden burst due to the sudden output of the engine. To ensure safety, please do not perform linking when the servo and engine are running.

When linking is finished, click the status bar to return to the upper menu.

Receiver port setting

This function is used to customize the port output function channel of the receiver. For the corresponding channel function, please go to [Channel setting] of [CH set] to set.

Tip: All ports can be customized channels, but PPM and W.BUS can only be set to port 8, and W.BUS2 can only be assigned to port 9 (RG209S receiver).

Note: **【Receiver port setting】** needs to be set when only one receiver is connected.

Function path: [Menu]-[Linkage menu]-[Receiver port setting].

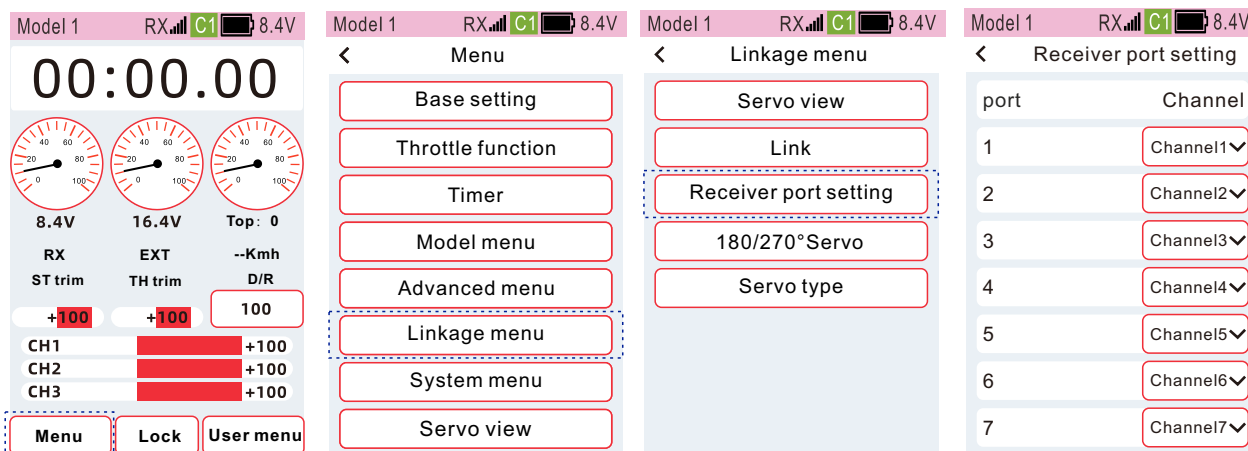

How to set the receiver port channel

- Click the channel setting item, select the desired channel from the drop-down list.
- After the setting is completed, click the title bar to return to the previous menu.

Note:

When the code is completed and the receiver is powered on, the transmitter enters [Receiver port setting] again for setting. If the receiver isn't connected, enter the menu, and there will be a pop-up reminder on the right:

Note

Receiver is not connected and cannot be set up.

Back

Check

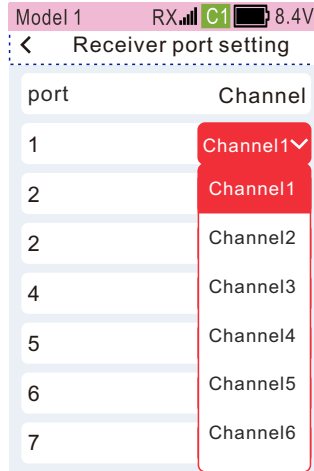
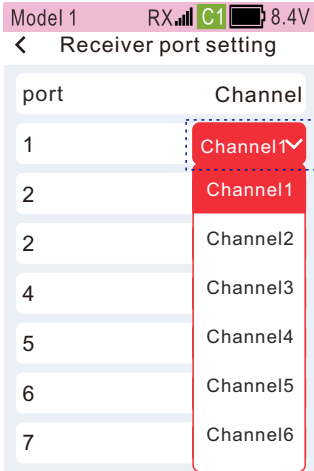

180/270° Servo

End point for large angle servos, disabled by default

Tip: It is generally used in servo settings with large movement strokes such as tanks or robots.

Function path: [Menu] - [Linkage setting] - [180/270° Servo]

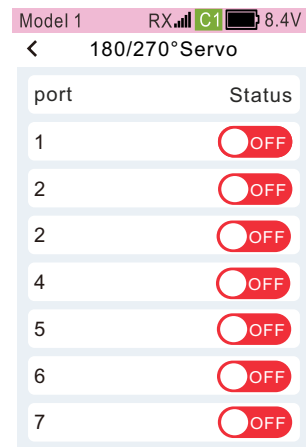
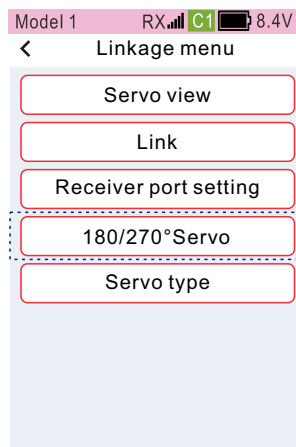
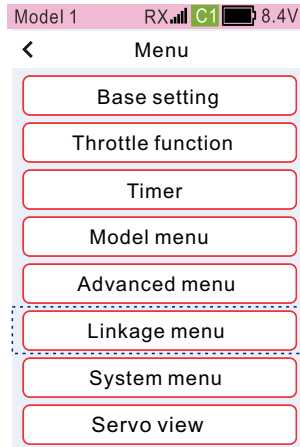
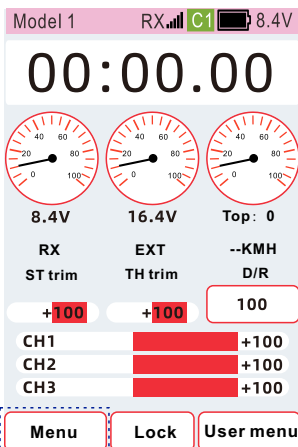

How to set 180/270° servo status

When the status is set to [On], the function is enabled, and when it is set to [Off], the function is not enabled.

ON : Indicates that the state is on

OFF : Indicates that the status is off

Note:

When the receiver's code alignment is completed and the receiver is powered on, the transmitter enters the [180/270° steering gear] again to set up.

If the receiver is not received, enter the menu, there will be a pop-up reminder on the right:

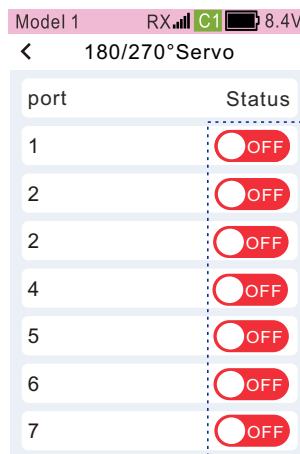

Note

Receiver is not connected and cannot be set up.

Back

Check

Servo type

When using a digital servo, adjust the output mode of the receiver to match the operating frequency of the servo to better play the performance of the servo.

Send the setting data to the receiver when the exit is exited.

Reminder: When using a normal servo, be sure to set it to the [Normal] mode, and it may cause damage to the servo.

Function path: [Menu]-[Linkage menu]-[Servo type]

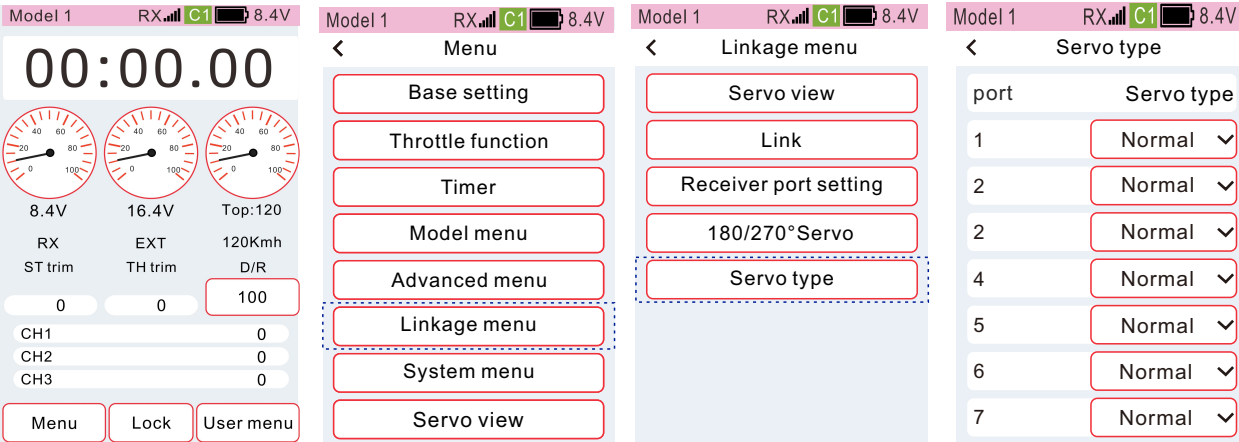

How to set the servo type

- Click the servo type setting item, and select the desired servo type from the drop-down list.
- After the setting is completed, click the title bar to return to the previous menu.

Note: The conventional servo uses analog mode. If the conventional servo uses digital mode, it may cause the steering gear to burn.

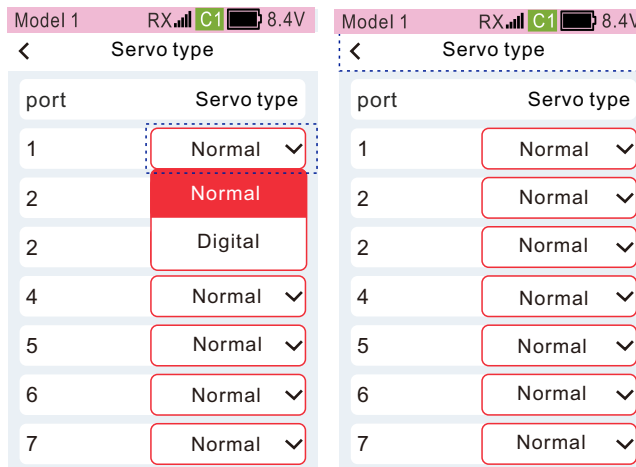

System menu

User menu Setting

You can add your commonly used functions to the user menu, a total of 14 options, a total of 24 functions can be set. The user menu changes synchronously with the model data. There is not much difference between the model data, and when the user menu uses the same settings, you can perform shortcut operations through [Model menu] [Copy].

Function path: [Menu]-[System menu]-[User menu setting]

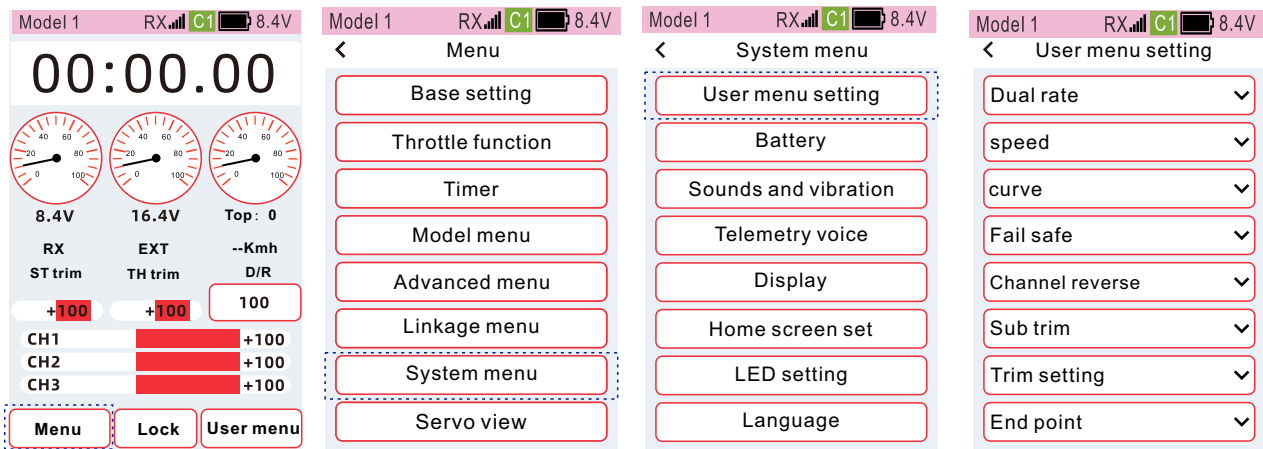

Calling up the user menu interface:

- Call up the user menu interface through physical buttons.

In [Advanced menu] [Channel setting] [CH set], select a switch in PS1, PS2, PS3, SW1, SW2 to set the function of [User Menu], you can quickly call up the [User Menu] interface by pressing the button.

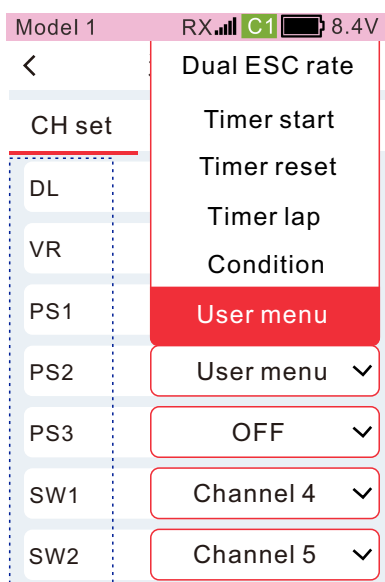
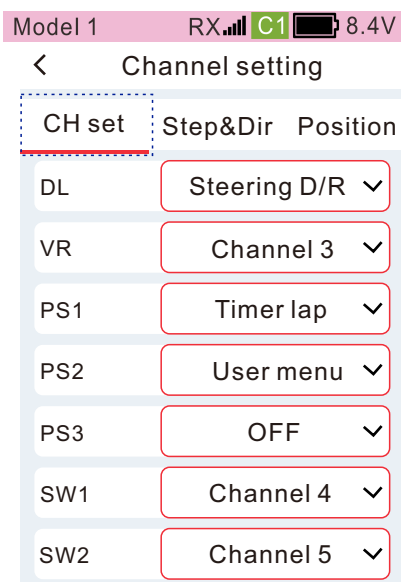
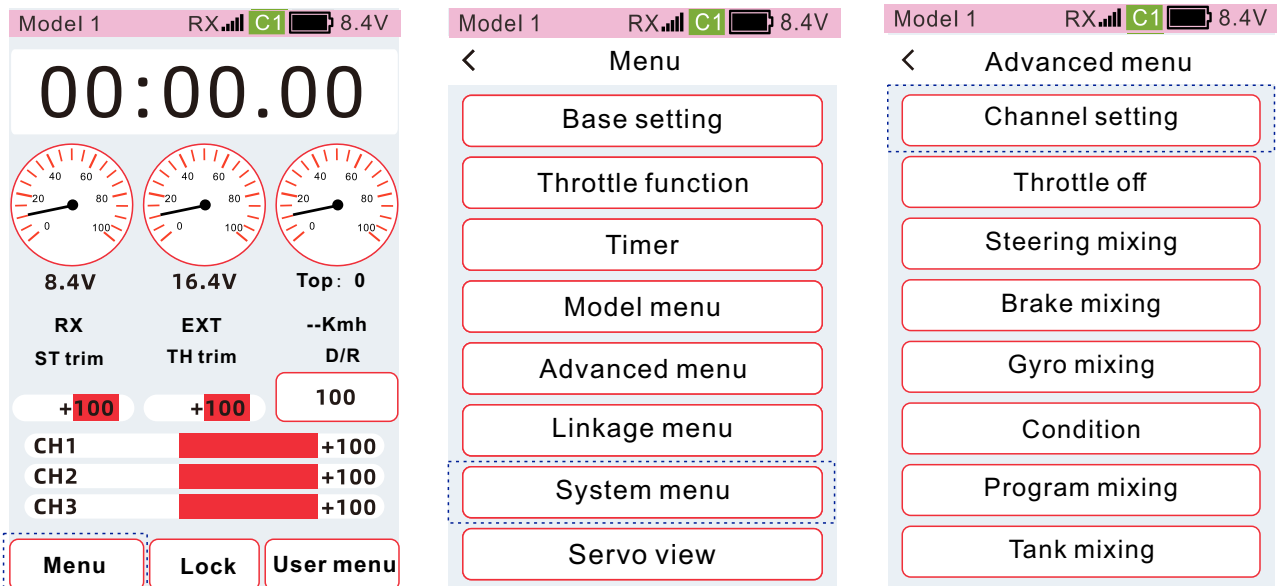

•Call out through [Menu] [User menu]:

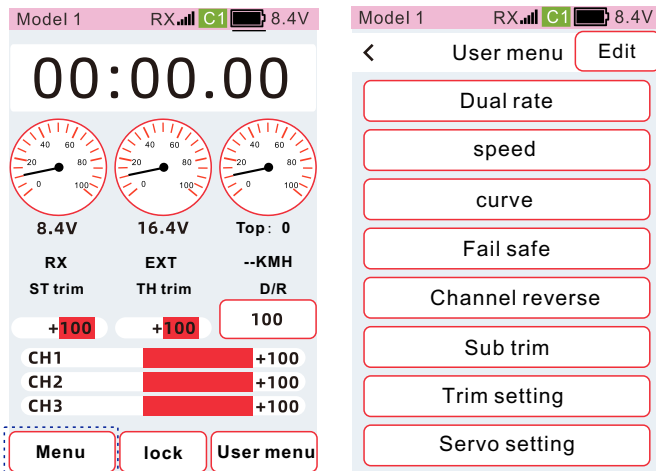

Editing of the user menu interface:

Click the [Edit] button in the upper right corner of the interface to enter the editing state, Select the desired function from the drop-down list.
 After the setting is complete, click the status bar to exit the editing mode

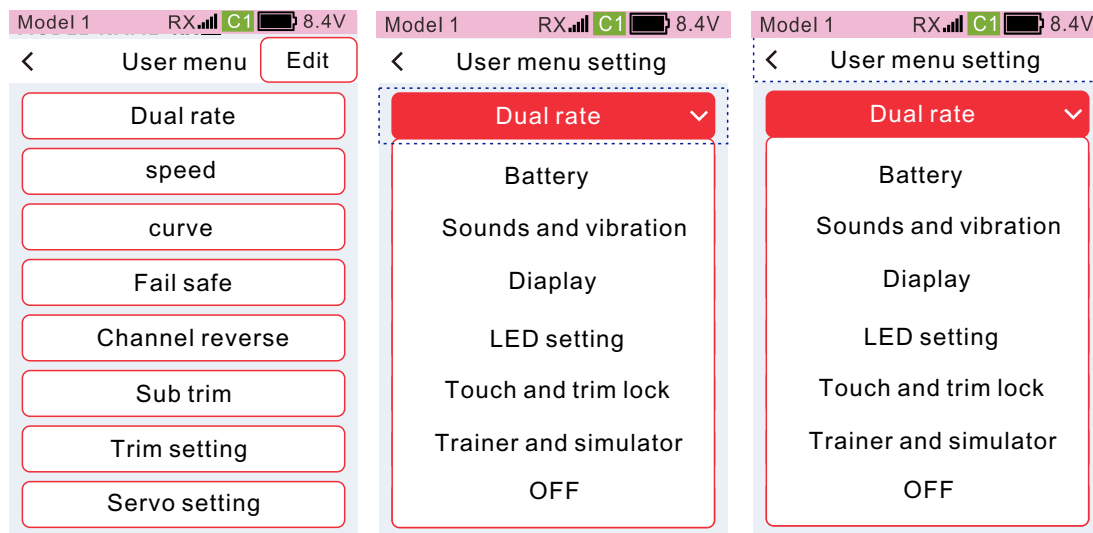

Battery

By setting the alarm trigger value, an alarm prompt will be given when the voltage is low. Avoid accidents caused by the control system running for a long time in a low voltage state.

Function path: [Menu]-[System menu]-[Battery]

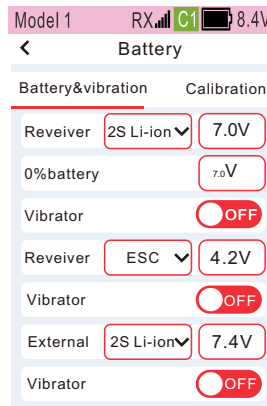
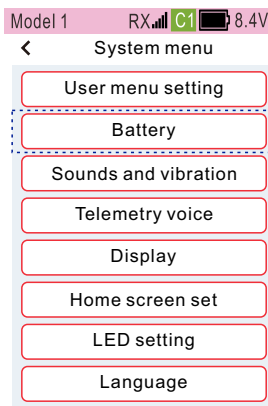
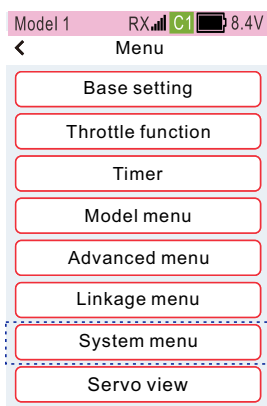
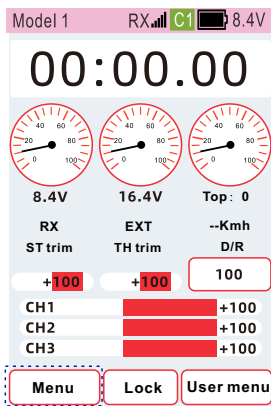

Battery voltage range setting

Transmitter:

Battery Type

2S lithium battery: the setting range is 7.4V~8.4V,

18650 lipo batteries: 2S 3.7V batteries, the setting range is 6.8V~8.4V.

Voltage: Adjust the alarm voltage, will affect the status bar voltage icon power display.

Vibration: When the alarm value is triggered, there is a vibration reminder.

Power supply battery type, self-detection at power-on (1S lithium battery/4AA)

1: 8.5V transmitter 6.9V, can no be power on.

2: When the transmitter voltage, receiver battery voltage, power battery voltage is lower than the set voltage, the speaker will broadcast the corresponding voice reminder, such as [transmitter low 7.0V], and set whether to turn on the vibration reminder as required.

3: Low voltage protection mode (under normal working condition)

*TX≤6.4V low voltage warning pop-up window (low battery) (continuous drops of sound) with confirmation button (click the confirmation button to close the pop-up window, Turn off the warning sound, after clicking to close the popup window, there will be no pop-ups and drops for about 1 minute)

*TX≤6.2V low voltage shutdown popup window (will automatically shut down) (continuous drops of sound) with forced shutdown popup window (click forced shutdown popup window, that is, shut down)

*TX ≤5.9V Low voltage shutdown (automatic shutdown), the power supply voltage is too low to maintain the startup state.

Receiver

Power supply Type:

Electric regulation: Use electric regulation power supply, alarm voltage is 4.2V

1S lithium: single lithium power supply, alarm voltage is 3.7V

2S lithium: two lithium power supply, alarm voltage is 7.4V

Custom: Customize the power supply voltage, ranging from 3.5V to 8.0V

Vibration: When the alarm value is triggered, there is a vibration reminder.

Power battery

Power supply Type:

1S lithium: single lithium power supply, alarm voltage is 3.7V

2S lithium: two lithium power supply, alarm voltage is 7.4V

3S lithium: 3 lithium power supply, alarm voltage is 11.1V

Custom: Customize the power supply voltage, ranging from 0.0V to 96.0V

Vibration: When the alarm value is triggered, there is a vibration reminder.

Battery&Vibration

How to set the transmitter battery type

Click the battery type setting item and select the battery type you want to set from the drop-down list

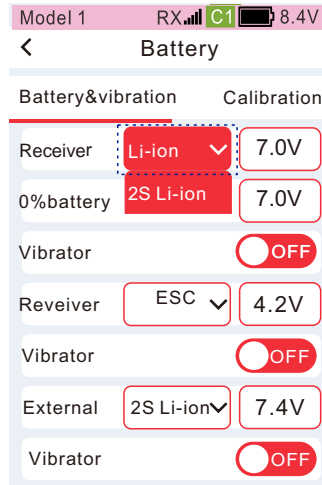

How to set transmitter alarm voltage

Click the "Battery" setting item, and set the value focus to display as the theme color (the default theme is red).The bottom of the screen shows 【-】 【Reset】 【+】

Click or hold [-] [+] to adjust the value.

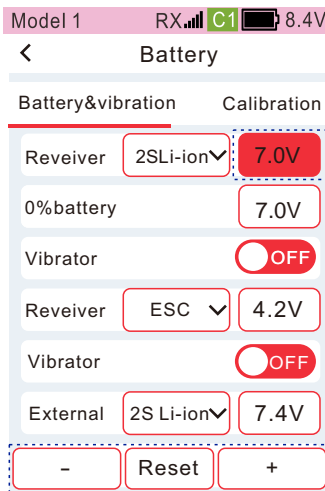

Transmitter 0% battery setting method

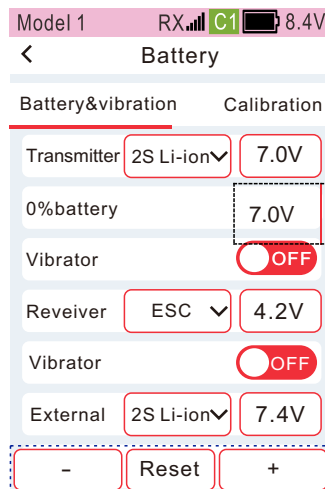

①Click the [0% battery] setting item, the setting value is focused and displayed as the theme color (the default theme is red), and the bottom of the screen displays [-] [Reset] [+].

②Click or long press 【-】 【+】 to adjust the ratio.



Setting method of transmitter alarm voltage vibration

When the status is set to [ON], the function is enabled, and when it is set to [OFF], the function is not enabled. Vibration type: set in [Menu]-[System menu]-[Battery and vibration]-[Vibrator].

: Indicates that the state is on
: Indicates that the status is off

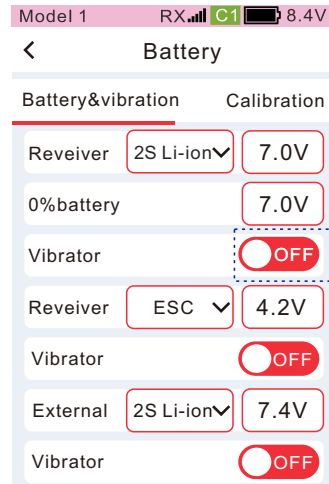

How to set the receiver battery type

Click the battery type setting item, and select the desired battery type from the drop-down list.

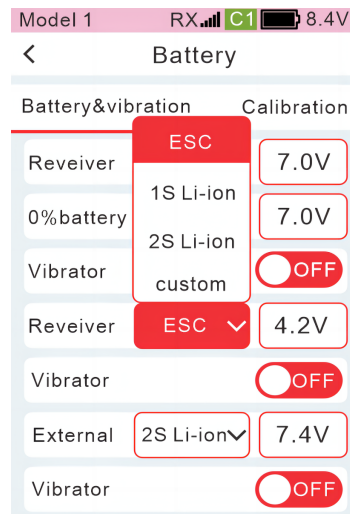

How to Set Receiver Alarm Voltage

① Click the setting item of [Battery], the setting value is focused and displayed as the theme color (the default theme is red), and the bottom of the screen displays [-] [Reset] [+].

② Click or long press **[-]** **[+]** to adjust the ratio.

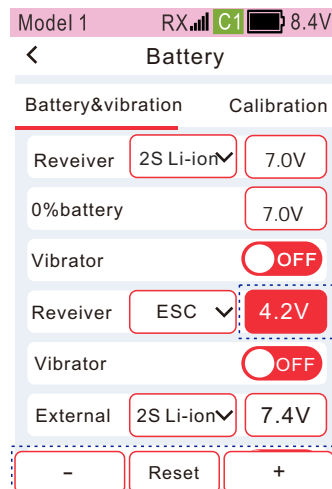

How to Set Receiver Alarm Voltage Vibration

When the status is set to [On], the function is enabled, and when it is set to [Off], the function is not enabled. Vibration type: set in [Main Menu]-[System menu]-[Battery and vibration]-[Vibrator].

: Indicates that the state is on

: Indicates the state is off

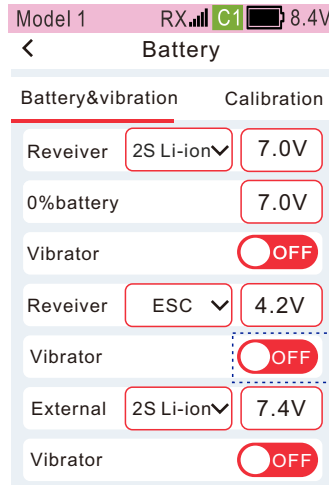

How to set the battery type of External battery

Click the battery type setting item, and select the desired battery type from the drop-down list.

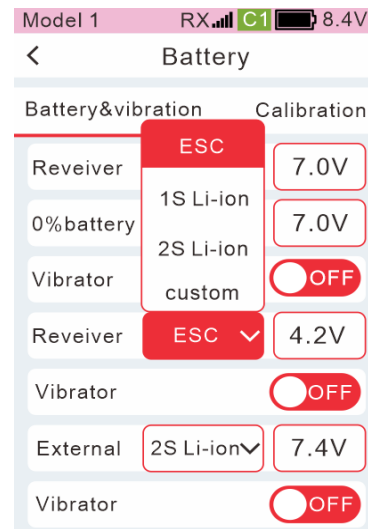

Setting method of power battery alarm voltage

① Click the [Battery] setting box, the setting value is focused and displayed as the theme color (the default setting theme is red), and the bottom of the screen displays [-] [Reset] [+].

② Click or long press **[-]** **[+]** to adjust the rate.

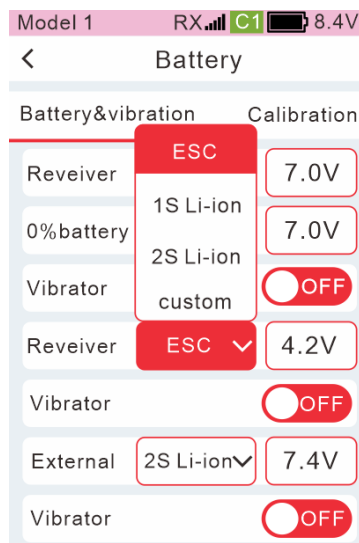

Setting method of power battery alarm voltage vibration

When the status is set to [ON], the function is enabled, and when it is set to [OFF], the function is not enabled. Vibration type: set in [Menu]-[System menu]-[Sound and Vibration]-[Vibration].

: Indicates that the state is on

: Indicates the state is off

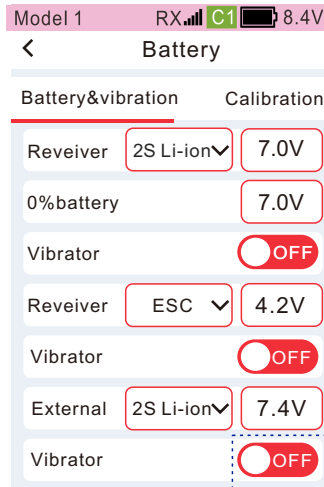

Voltage calibration

Since there may be errors in electronic components, there may be errors between the measured voltage and the actual battery voltage. Users can correct the errors through the battery calibration function.

Transmitter, Range: ± 1.0 Volts.

Receiver, Range: ± 1.0 Volts.

Power battery, range: ± 3.0 volts.

Function path: [Menu]-[System menu]-[Battery]

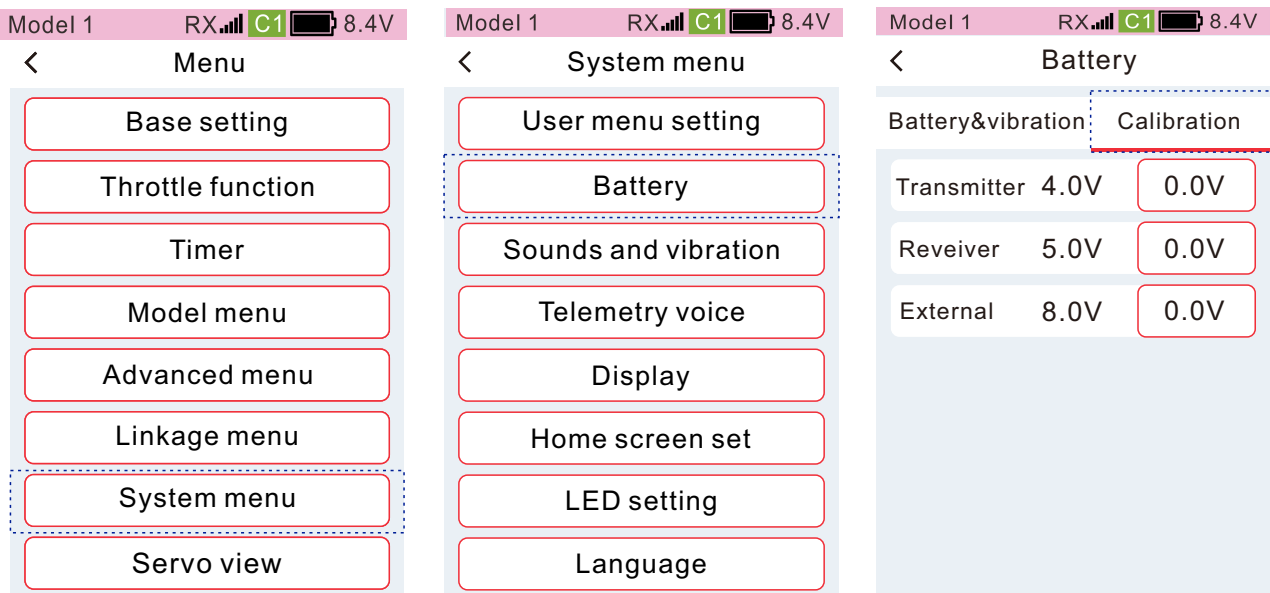

Setting method of voltage calibration value of transmitter, receiver and power battery

①Click the setting item of [Calibration], the setting value is focused and displayed as the theme color (the default theme is red), and the bottom of the screen displays [-] [Reset] [+].

②Click or long press **[-]** **[+]** to adjust the ratio.

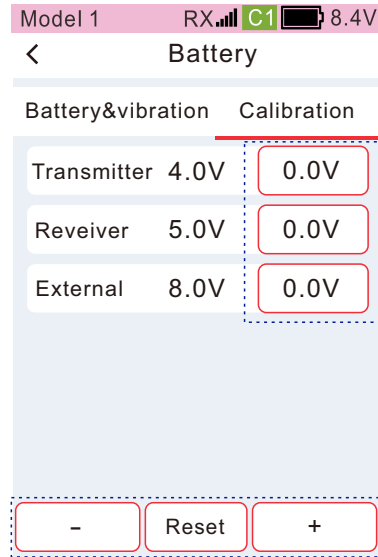

Sound and vibration

Beeps and vibrations help you notice various anomalies or planned sound alerts during flight. The sound and vibration are associated with the model, and the sound and vibration can be set according to the needs of each model.

Sound:

Warning: low transmitter voltage, low receiver voltage, low power battery voltage.

Telemetry voice: receiver voltage, power battery voltage, model speed. Trim: DT1, DT2, DT3, VR, DL minimum trim, maximum trim, trim midpoint. Timer: start timing, pause timing, timing reset, laps. The first few minutes. Countdown reminder.

Key volume: touch screen keys, screen lock/unlock sound.

Others: function on and off (such as ABS on and off), mode switching (for example: four-wheel steering, front-wheel steering, rear-wheel steering, four-wheel steering. Unmarked voices.

Vibration:

Transmitter low battery:

Receiver low battery:

External low battery:

Timer:

Vibration type

Type 1: continuous vibration for 2 seconds, 5 seconds interval.

Type 2: vibration 0.25 seconds, interval 0.25 seconds, vibration 0.25 seconds, interval 5 seconds.

Type 3: vibration 0.5 seconds, interval 0.5 seconds, vibration 0.5 seconds, interval 5 seconds

Type 4: vibration 0.75 seconds, interval 0.75 seconds, vibration 0.75 seconds, interval 5 seconds

Type 5: vibration 1 second, interval 1 second, vibration 1 second, interval 5 seconds.

Type 6: vibration 1.25 seconds, interval 1.25 seconds, vibration 1.25 seconds, interval 5 seconds

● Function path: [Menu] - [System menu] - [Sound and vibration]

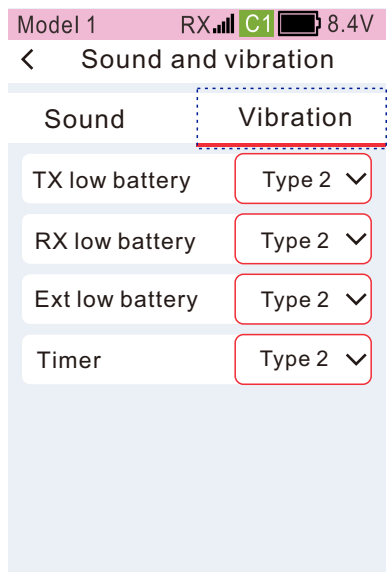
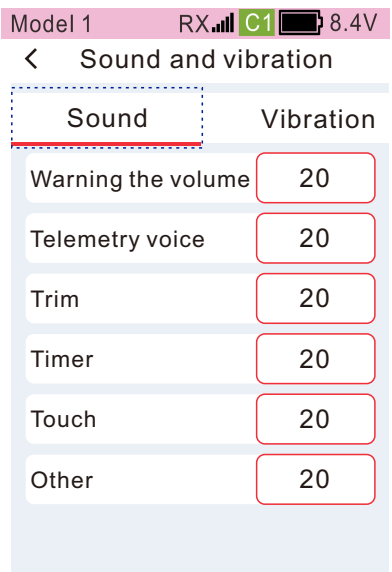
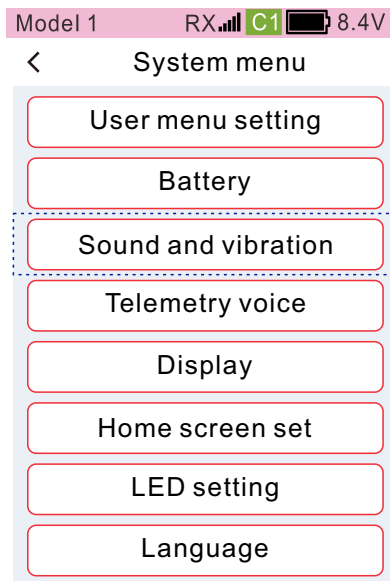
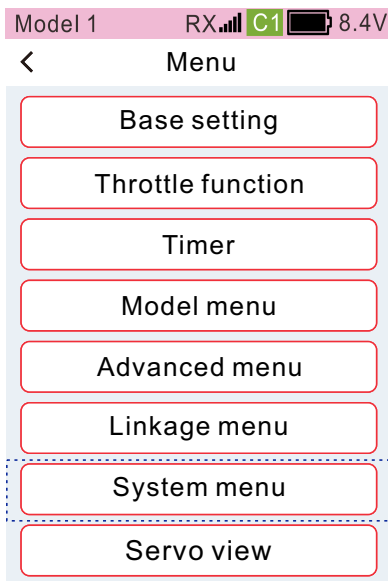
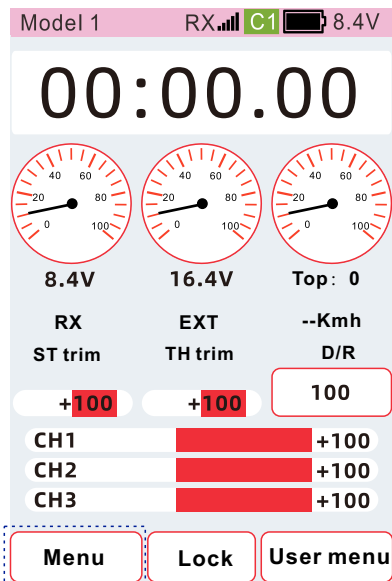

How to set the volume of the sound

① Click the [Sound] setting item, the setting value is focused and displayed as the theme color (the default setting theme is red), and the bottom of the screen displays [-] • [Reset] [+].

② Click or long press [-] [+] to adjust the rate.

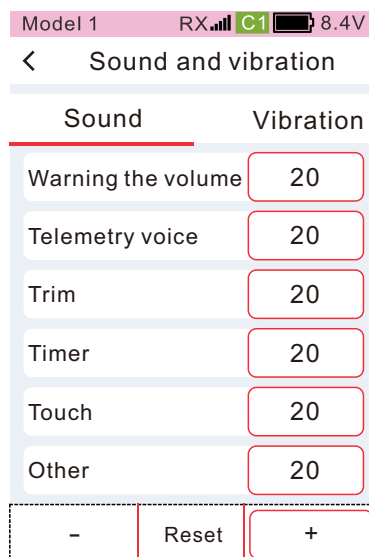

How to set the vibration type

Click the [Vibration type] setting item, and select the desired vibration type from the drop-down list.

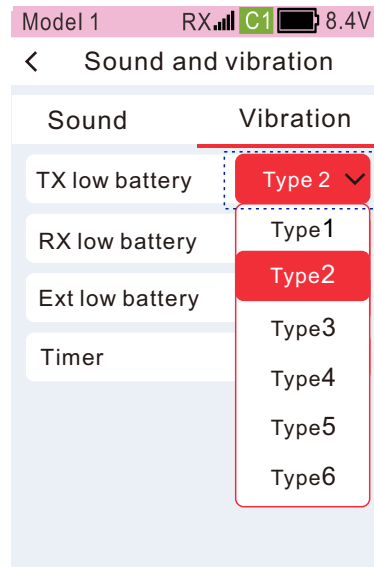

Telemetry voice

This function can set the on/off, times and interval of telemetry voice announcement.

Voice announcement interval

The interval between the first sensor and the second sensor.

Repeat play times

The number of voice broadcasts from the same sensor.

Repeat interval

The interval between the 1st and 2nd times when the same sensor broadcasts multiple times.

Function path: [Menu]-[System menu]-[Telemetry voice]

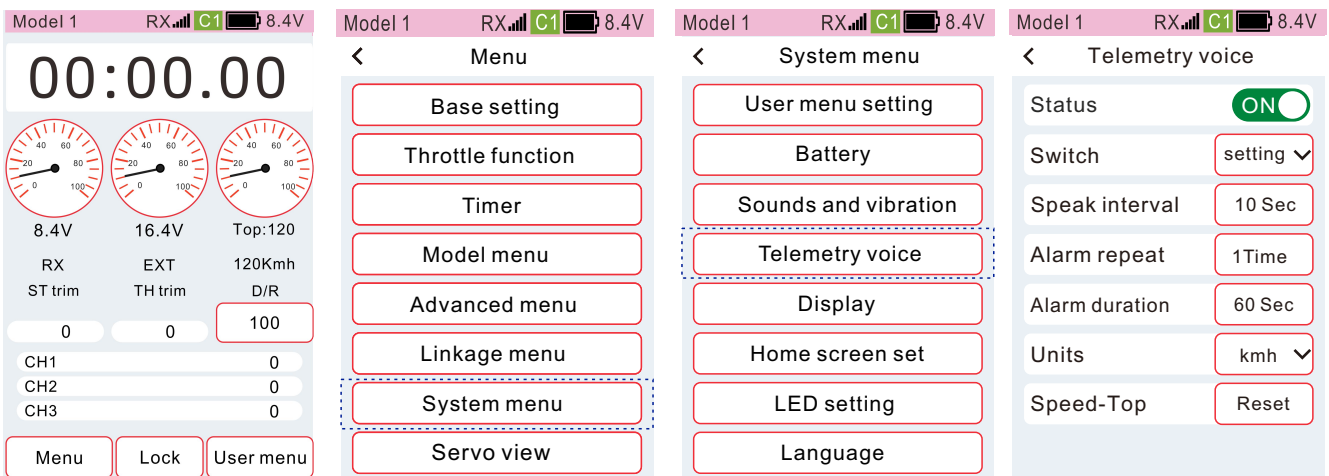

Setting method of telemetry voice state

When the state is set to [On], the function is enabled, and when it is set to [Off], the function is not enabled.

: Indicates that the state is on

: Indicates the state is off

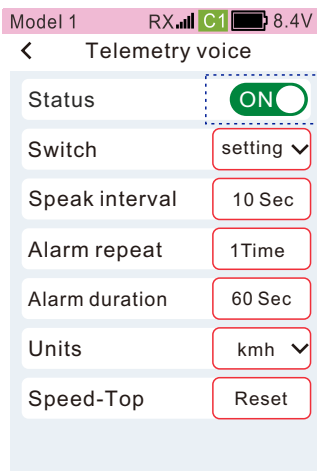

How to set voice broadcast interval, repeat broadcast times, and repeat interval

① Click the setting item, the setting value is focused and displayed as the theme color (the default setting theme is red), and the bottom of the screen displays [-] [Reset] [+].

② Click or long press **[-]** **[+]** to adjust the ratio.

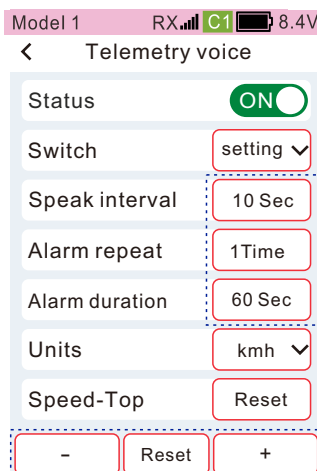

Display setting

This function can adjust the brightness of the display backlight, the backlight time, the automatic shutdown time, and the theme, so as to adapt to different use environments and save energy.

Function path: [Menu]-[System menu]-[Display]

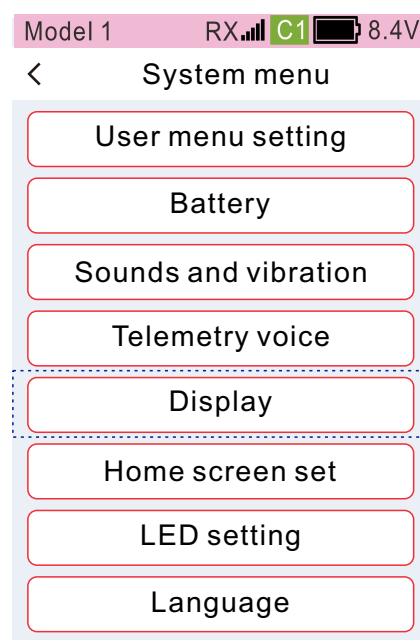
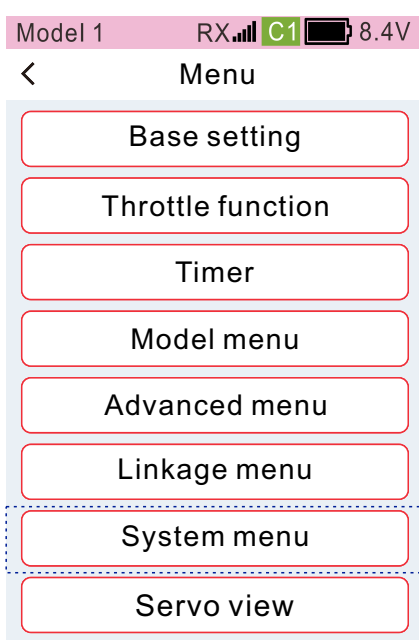
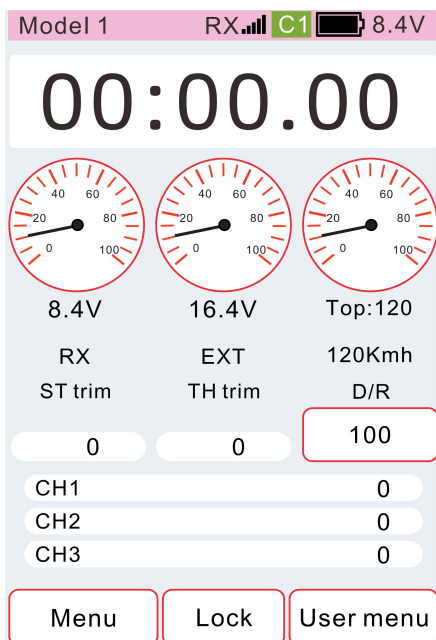

Backlight max: The highest brightness value

Backlight min: The darkest brightness value

Backlight time: Refers to the time when the key and touch screen operation is not detected. After the set value, the backlight switches to the value set by "Darkest Backlight".

Automatic shut down: the transmitter will shutdown after no operation
Screen calibration: According to the characteristics of the resistive screen, the corresponding contacts may drift after long-term use.

Therefore, it is necessary to recalibrate the coordinate position of the touch point of the screen.

Theme: Set theme color.

How to set the maximum backlight and minimum backlight

① Click the setting item, the setting value is focused and displayed as the theme color (the default setting theme is red), and the bottom of the screen displays [-] [Reset] [+].

② Click or long press **[-]** **[+]** , adjust 1, default value: 102, range: 1~203, step value: 1

Decreasing : [Brightest Backlight Intensity] will force the setting value of [Backlight max] to be 1 less than [Maximum Backlight].

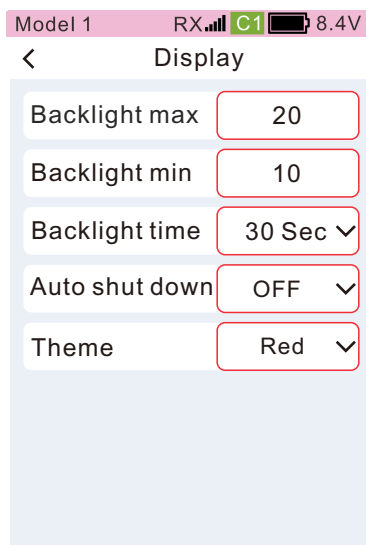

Home screen set

This function can be user defined, [Widget setting] can set function location, including image, channel, function, status, trim, Gauge(L), Gauge(B), [Widget function] can set specific function.

Path: [Menu]-[System menu]-[Home screen set]

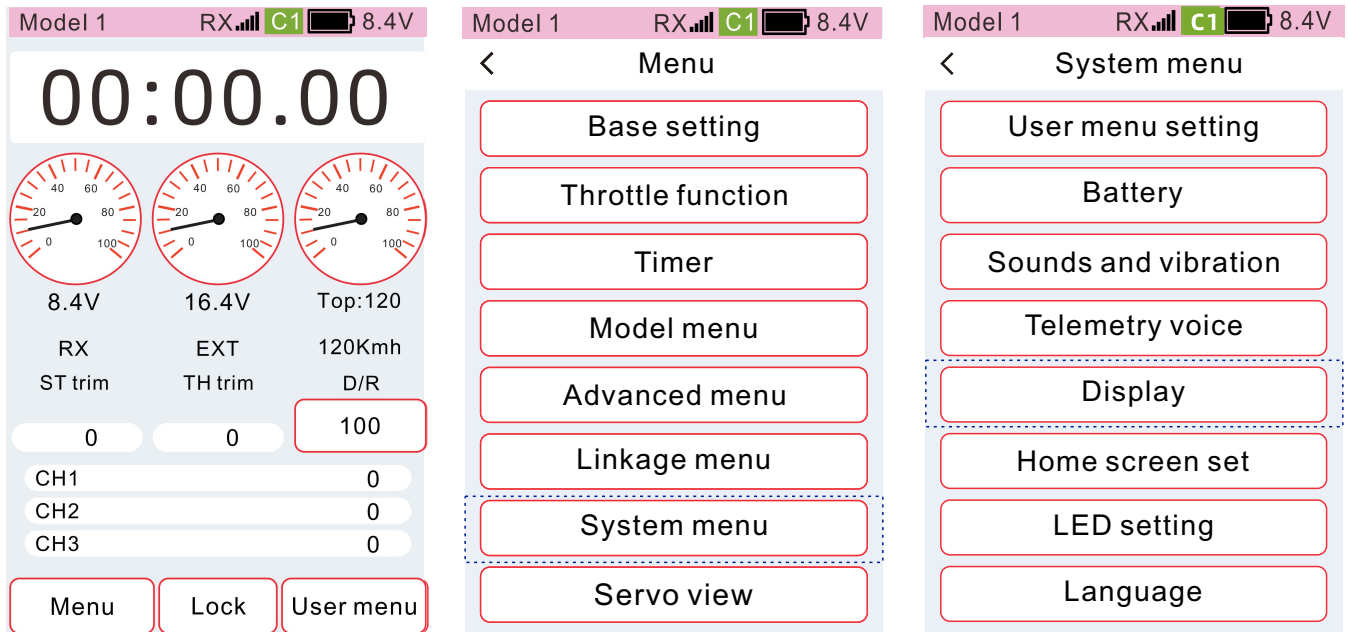

Function steps: [Widget setting] - [Widget function]

Widget setting: click [Widget setting] small window, click any menu function type, 15 positions can be allocated.

Set items:

- Timer(Occupy 3 lateral positions)
- Image(Occupy 3 lateral positions)
- Channel(Occupy 3 lateral positions)
- Function(Occupy 1 position)
- Status(Occupy 1 position)
- Trim(Occupy 1 position)
- Gaugel(L)(Occupy 2 longitudinal po
- Gaugel(B)(Occupy 2 longitudinal po
- Not set(Occupy 1 position)

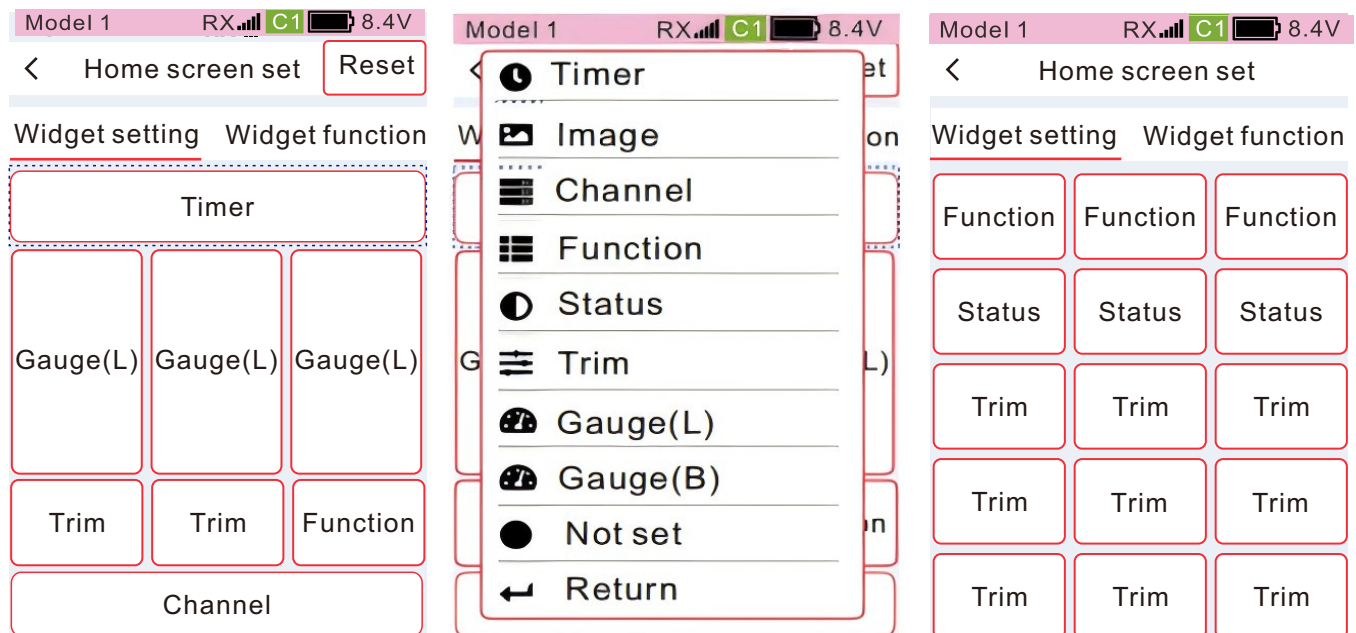

Function steps:[Widget setting] - [Widget function]

Widget function:Select[Widget function],click[Widget function] window,set the window submenu function

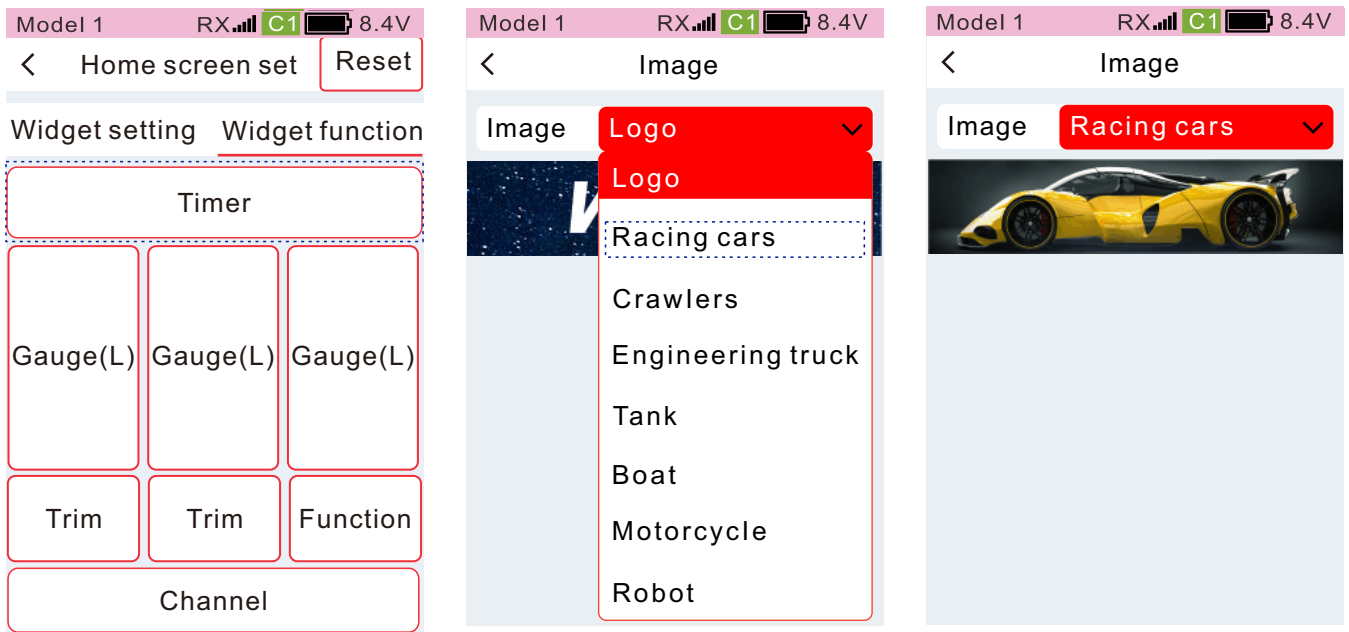

Set item:

Not set: This area is blank on the home screen

Image: Racing cars,Crawlers,Engineering truck,Tank,Boat,Motorcycle,robot

Trim: direction, throttle, CH3, CH4, CH5, CH6, CH7, CH8, CH9

Gauge(B): EXT, RX, SPEED,STR, THR, CH3, CH4, CH5, CH6, CH7, CH8, Ch9

Gauge(L): EXT, RX, SPEED,STR, THR, CH3, CH4, CH5, CH6, CH7, CH8, Ch9

Status: A.B.S., throttle idle, throttle off, steering mix, brake mixing CH3,brake mixing CH4, gyro, prog mix1, prog mix2, prog mix3,prog mix4, prog mix5,tank mixing, dual ESC, 4WS mixing

Function: External volt, receiver volt, Speed, Speed -Top, Steering D/R, Brake rate,STR turn speed, STR return speed,Gyro,4WS,Dual ESC,SW1,SW2 Speed-throttle forward, speed-throttle return, forward curve, brake curve, gyro, 4WS steering, dual ESC, SW1, Sw2

Upper indicator bar: direction, throttle, CH3, CH4, CH5, CH6, CH7, CH8, Ch9

Channel: Indicator bar: direction, throttle, CH3, CH4, CH5, CH6, CH7, CH8, Ch9

Down indicator bar: direction, throttle, CH3, CH4, CH5, CH6, CH7, CH8, Ch9

LED setting

This function can be used to set the direction indicator, the on/off of the atmosphere indicator, the effect, the trigger position and the forward and reverse directions.

Function path: [Menu]-[System menu]-[LED setting]

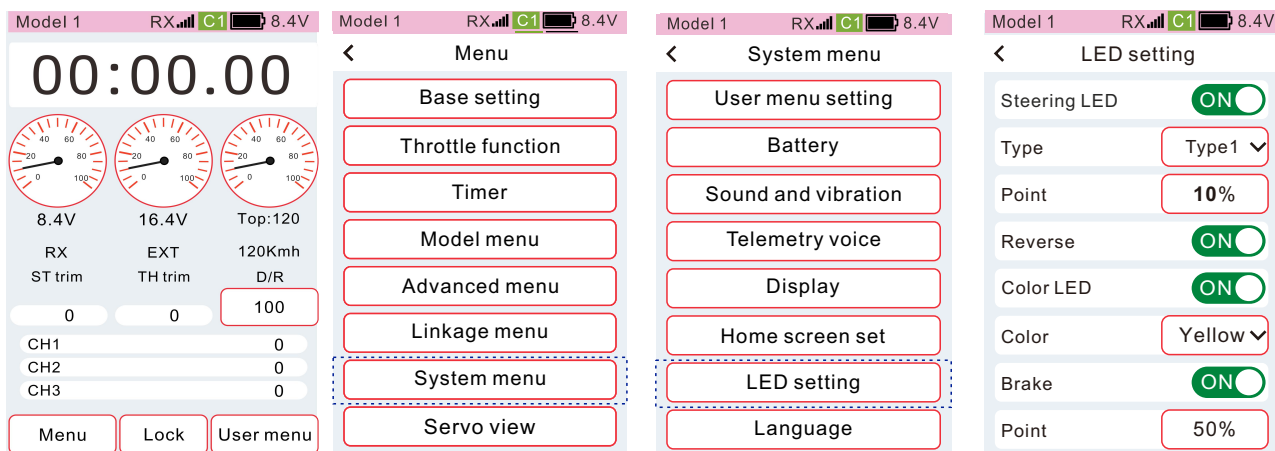

LED setting: Set the steering indicator light on and off.

ON: The direction indicator is on Off: The direction indicator is off.

Effect: Provides a variety of indicator dynamic effects for setting.

Point: Set the trigger position to light up the indicator light. When the trigger position is reached, the direction indicator light will be turned on.

Reverse: the setting of the left and right status of the indicator light.

Nor: The trigger is on the left, the indicator light on the left is lit, or from right to left.

Rev: The trigger is on the left, the light on the right is on, or from left to right.

Color LED: Set the on and off status of the atmosphere indicator.

Color: You can set the color of the atmosphere indicator, which can be set to white, blue, cyan, green, yellow, purple, red.

Braker: turn on brake indicator, fixed as red flash, no trigger position: turn on brake indicator trigger position. When the trigger position is reached, the brake indicator light function is enabled.

Language

Selection interface display language, X9S provides English interface display.

● Function path: [Menu]-[System menu]-[Language]

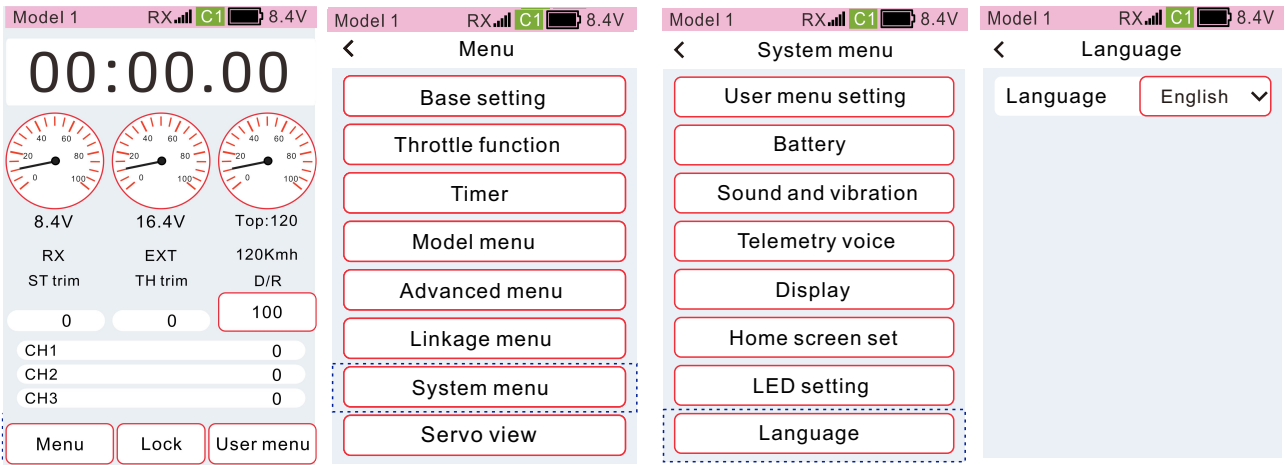

Trainer and simulator

► Trainers can assist students to learn manipulation skills and improve their manipulation level according to their own manipulation experience and operation level.

► A dedicated trainer cable (sold separately) is required to connect between the trainer and the student aircraft, and the trainer must turn on the trainer mode before the student aircraft can be controlled. When the trainer switch is turned off, it will return to the trainer transmitter control model. When the control of the student aircraft is dangerous or the deviation is too large, it can be switched immediately to ensure safety.

● Function path: [Menu] - [System menu] - [Trainer and simulator]

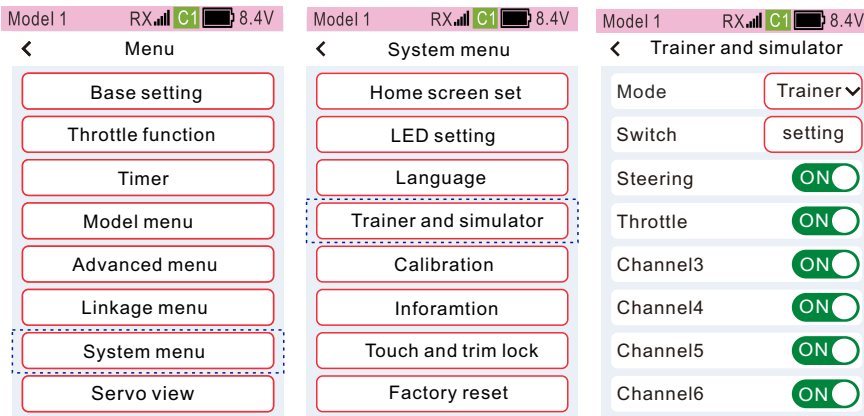

● **Mode:** Set [Normal], [Trainer], [Simulator], [Student] mode Switch.

● **Selection:** Set the control switch of trainer on/off

● **Channel switch:** The state of each channel of the trainer is on/off.

 ON: On, students can control;

 OFF: Students can not control it.

Calibration

Use the calibration function to correct when the throttle and steering wheel deviate mechanically.

Function path: [Menu] - [System menu] - [Calibration]

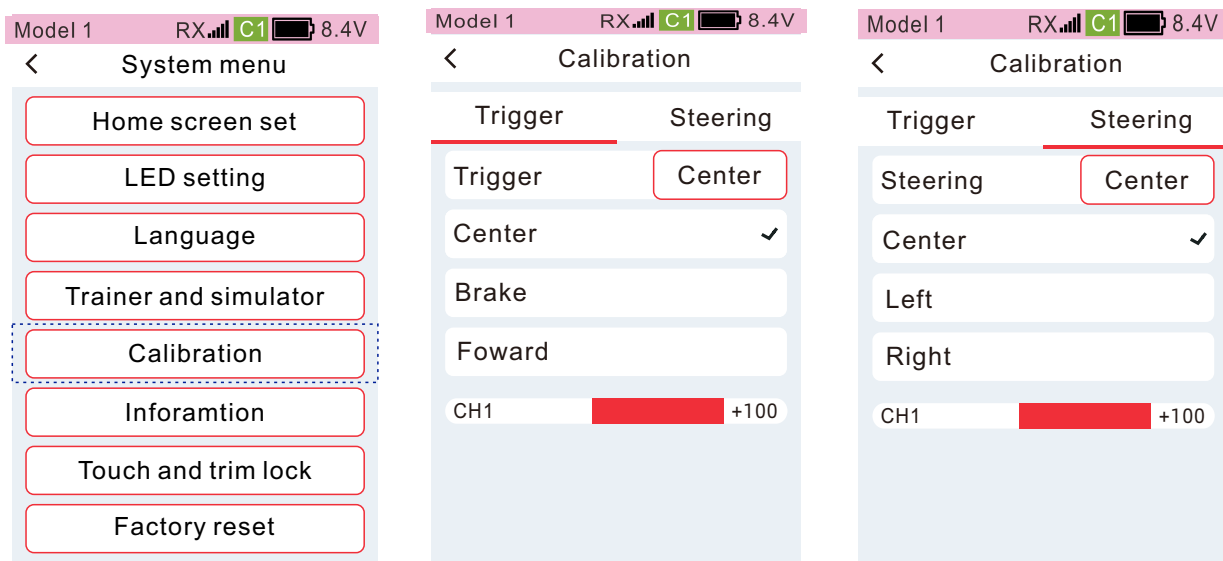

Trigger calibration

- ① Keep the wheel at the midpoint, and press the [Center] key. When the [✓] symbol appears to the right of the midpoint, go to the next step.
- ② Rotate the wheel to the endpoints on both sides respectively (just lean on it, as shown in the figure below), when the [✓] symbol appears on the right side of the left endpoint and the right endpoint, go to the next step.
- ③ Click [OK] to complete the calibration and save the data

Steering calibration is the same way as Trigger calibration

Information

In this interface, you can view the model, firmware version, voice package version, and ID information, and you can download the manual. Follow the official WeChat account for more information. When the new firmware is officially released, you can click [Transmitter Upgrade] or [Voice Upgrade], make the transmitter in the upgrade state.

Function path: [Menu]-[System menu]-[Information]

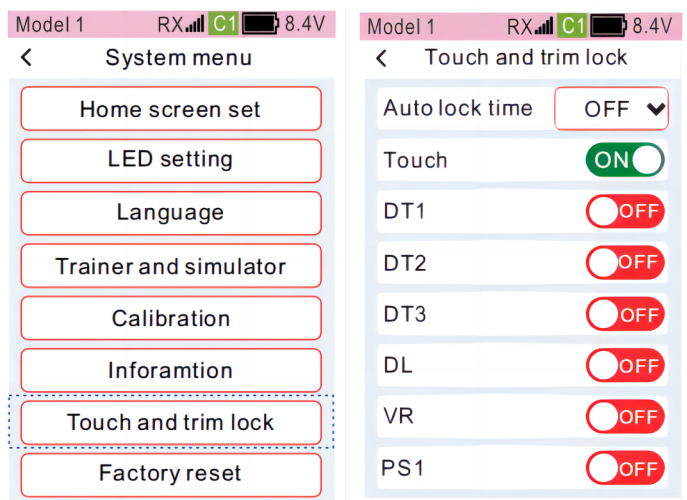

Please go to WFLY official website of www.wflysz.com to get the latest radio or receiver firmware to make a upgrading, thank you!

Touch and trim lock

The user can set the corresponding operation mode when the screen is locked to be invalid according to the specific usage scenario or personal operation habits, so as to avoid accidental operation and change the parameters of the remote control.

●Function path: [Menu] - [System menu] - [Touch and trim lock]

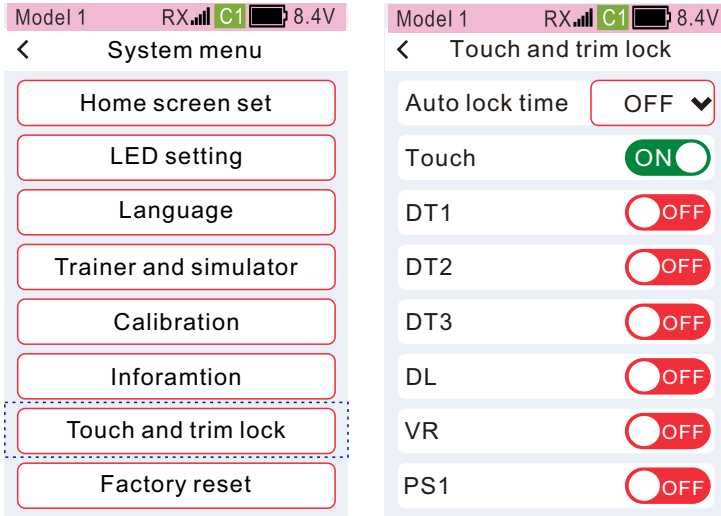

Factory reset

This interface resets the transmitter to the factory default parameter settings.

Reminder: Unaffected parameters: [Calibration] [Model menu - User Default Data]

●Function path: [Menu]-[System menu]-[Factory reset]

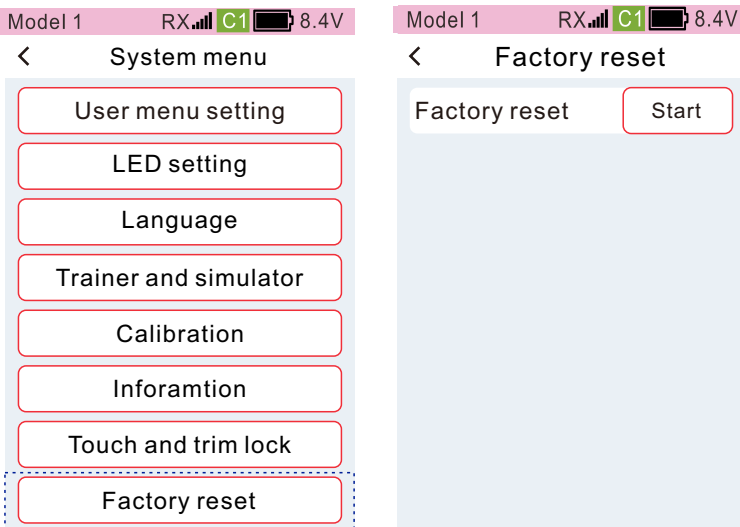

●Factory reset setting

Click Factory Settings [Start reset] to set the focus display as the theme color red, click the pop-up window [✓ yes] to confirm, restore the factory Settings, the setting is complete, click the title bar to return to the upper level menu.

② In the pop-up window, click [X No] to cancel.