



# WFT09SII

RADIO CONTROL SYSTEM PCMS 4096

PCMS Receiver, Dual MCU, Dual Antenner. Dual circuits

## INSTRUCTION MANUAL<sub>v2</sub>



### NOTICE

Read the instruction before operation!

[www.wflysz.com](http://www.wflysz.com)

Thank you for purchasing **WFLY**<sup>®</sup> product!

## WFT09SII



### SERVICE

1. Retailers to provide free maintenance for six months (apart from artificial damage)
2. WFLY retailers will always provide life-long maintenance

## CATALOGUE

Contents-----	08
Transmitter front-----	09
Transmitter back-----	10
Receiver-----	11
Trainer function-----	12
Flying safety warnings-----	13
Features-----	14
Buttons-----	15
2.4G Code matching-----	16
Adjust the stick head-----	17
Change the throttle direction of mode1 or 2-----	18

## HELICOPTER SYS SETTING

1. Model selecting-----	23
2. Model name-----	24
3. Model setting-----	25
4. ATL-----	26
5. Modulation setting-----	27
6. RF setting-----	27
7. Swash select-----	28
8. Stick setting-----	29
9. Adjustment-----	30
10. Reset setting-----	31
11. Send data-----	32
12. Receive data-----	33
13. Sound-----	34
14. Contrast setting-----	35
About-----	35
Language-----	36

## NORMAL SETTING

1. Monitor-----	37
2. Dual rate & Exponential-----	38
3. Servo reverse-----	39
4. End point-----	40

5. Sub trim-----	41
6. Swash param setting-----	42
7. Auxiliary channels setting-----	43
8. Throttle curve setting-----	44
9. Pitch curve setting-----	46
10. Revolution mixing-----	48
11. Trim step setting-----	49
12. Throttle cut setting-----	50
13. Fly model switch-----	51
14. Throttle holding setting-----	52
15. Fail safe-----	53
16. TIMER-----	54

## ADVANCED

(1). GYRO sens setting-----	56
(2). Throttle hovering setting-----	57
(3). Pitch hovering setting-----	58
(4). HI/LO PIT Setting-----	59
(5). Trim offset setting-----	60
(6). DELAY-----	61
(7). Governor mixing-----	62
(8). Swash and THR mixing-----	63
(9). Cuve setting-----	64
(10). PROG.NOR.MIX1-7-----	67
(17). PROG.CUR.MIX1-4-----	68
(21). Throttle needle mixing-----	69
(22). Code matching-----	69

## AIRPLANE SYS SETTING

1.Model selecting-----	73
2.Model name-----	74
3.Model setting-----	75
4.ATL-----	76
5.AIL-2-----	77
6.Modulation setting-----	78
7.RF setting-----	79
8.Stick setting-----	80
9.Adjustment-----	81
10.Reset setting-----	82
11.Send data-----	83
12.Receive data-----	84
13.Sound-----	85
14.Contrast setting-----	85
About-----	85
Language-----	

## NORMAL SETTING

1.Monitor-----	86
2.Dual Rate & Exponential Setting-----	87
3.Servo Reverse-----	88
4.End Point-----	89
5.Sub Trim-----	90
6.Auxiliary Channels Setting-----	91
7.Throttle Curve Setting-----	92
8.Trim Step Setting-----	94
9.Flaperon-----	95
10.Flap Trim-----	96
11.Ail-diff-----	97
12.Elev-flap-----	98

13.Throttle Cut Setting-----	99
14.Idle Down-----	100
15.Fail Safe-----	101
16.Timer-----	102
17.Advanced-----	103

## ADVANCED

(1).curve Setting-----	105
(2)-(8).PROG.NOR.MIX1-7-----	106
(9)-(12).PROG.CUR.MIX1-4-----	107
(13).Air Brake-----	108
(14).Elevon-----	109
(15).Ailvator-----	110
(16).V-tail-----	111
(17).Snap-roll-----	112
(18).Delay-----	113
(19).Throttle Needle Mixing-----	114
(20).Gyro Sens Setting-----	115
(21).Code matching-----	115

## GLIDER SYS SETTING

1.Model Selecting-----	119
2.Model Name-----	120
3.Model Setting-----	121
4.Atl-----	122
5.Ail-2-----	123
6.Modulation Setting-----	124

7.RF Setting-----	124
8.Stick Setting-----	125
9.Adjustment-----	126
10.Reset Setting-----	127
11.Send Data-----	128
12.Receive Data-----	129
13.Sound-----	130
14.Contrast Setting-----	131
About-----	131
Language-----	131

**NORMAL SETTING**

1.Monitor-----	132
2.Dual Rate & Exponential Setting-----	133
3.Abk. Curve Setting-----	134
4.Servo Reverse-----	135
5.End Point-----	136
6.Sub Trim-----	137
7.Auxiliary Channels Setting-----	138
8.Trim Step Setting-----	139
9.Flaperon-----	140
10.Flap Trim-----	141
11.Ail-diff-----	142
12.Elev-flap-----	143
13.Fail Safe-----	144
14.Timer-----	145
15.Advanced-----	146

**ADVANCED**

(1).Curve setting-----	148
(2)-(8).PROG.NOR.MIX1-7-----	149
(9)-(12).PROG.CUR.MIX1-4-----	150
(13).butterfly-----	151
(14).elevon-----	152
(15).ailvator-----	153
(16).V-TAIL-----	154
(17).Start OFS-----	155
(18).Speed OFS-----	156
(19).Code matching-----	156

## Contents

Thank you for your attention and support to WFLY radio!

WFLY promises every WFT09S radio control system include the following contents:

1. **WFT09SII** 4096 transmitter
2. Battery holder for transmitter
3. Neckstrap
4. WFR09S 2.4GHz 9 channel receiver PCMS
5. Li-po Voltage Regulation

## WFT09SII Contents

### 1. Transmitter



### 2. Transmitter battery holder



### 3. Neckstrap



### 4. Li-po Voltage Regulation



### 5. WFR09S 2.4GHz 9ch receiver



# TRANSMITTER

MODEL NO.: **WFT09SII**

MODULATION: PPM, PCMS 1024, PCMS 4096

OUTPUT POWER:  $\leq 100\text{mW}$

POWER SUPPLY: 9.6-12V

CURRENT DRAIN: 250mA

Band: 2.4GHz

## TRANSMITTER FRONT

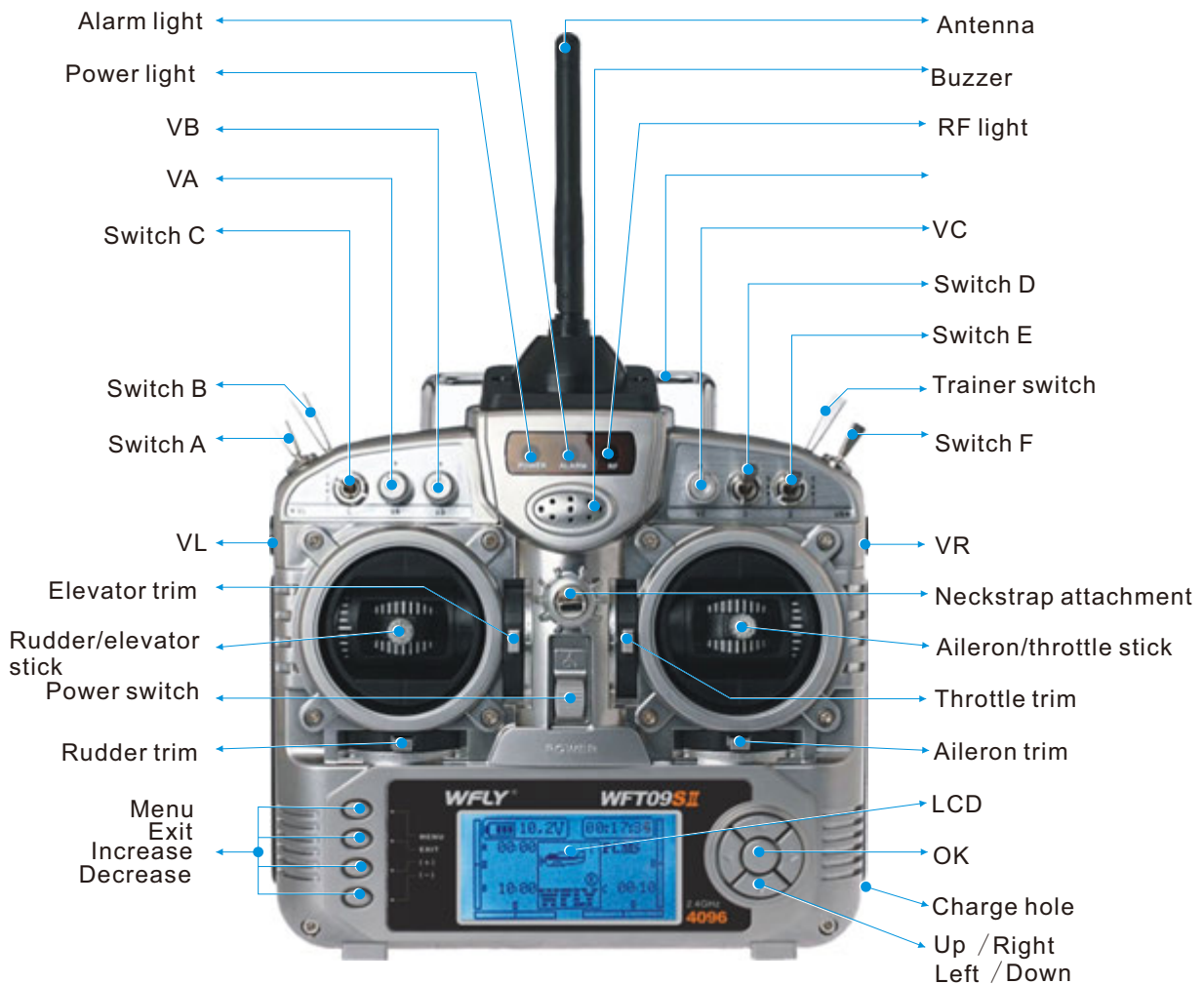

## TRANSMITTER BACK



**RECEIVER** Resolution 4096(with PCMS 4096 modulation)  
 2.4GHz 9 Channels receiver  
 Dual MCU, Dual antenna, Dual circuits, Resolution 4096 receiver  
 MODEL NO.: WFR09S  
 TYPE: 9 CH PPM /PCMS 1024/PCMS 4096  
 BAND: 2.400-2.483GHz  
 POWER SUPPLY: 4.8-6V  
 RECEIVER SENSITIVITY: -97dBm  
 WEIGHT: 14.8 g  
 DIMENSION: 44.8mm x27.9mm x16.39mm

**WFR09S 9 Channels Receiver (PCMS)**

- 1. AIL: Aileron (Channel 1)-----
- 2. ELE: Elevator (Channel 2)-----
- 3. THR: Throttle (Channel 3)-----
- 4. RUD: Rudder (Channel 4)-----
- 5. GYR: Landing Gear/Gyro (Channel 5)-----
- 6. PIT: Pitch (Channel 6)-----
- 7. AUX1: Auxiliary channel 1 (Channel 7)-----
- 8. AUX2: Auxiliary channel 2 (Channel 8)-----
- 9. Power: Input +4.8-6V-----



(There are 9 rows needles, 3 needles in each row, from the top needle to the bottom, the 3 needles are PCMS/PPM pulse, +5V and Ground.)  
 This receiver has Fail safe function.

**Characteristic**

- Can effectively select the best signal
- Enhance the reliability
- Improve the response speed
- Enhance the anti-interference
- Increased range of use



## **Trainer function**

Two WFT09SII transmitters can transfer data and realize trainer function.

## **Setting Method :**

- 1).Data transfer function: use Trainer cable/Data transfer cable to connect two WFT09SII transmitter.  
Select "Send data/receive data" in SYS setting to transfer the data.
- 2).Trainer function: use Trainer cable/Data transfer cable to connect two WFT09SII transmitters.  
Insert RF module to the trainer transmitter, student transmitter doesn't insert the RF module.  
Pull Trainer switch for student transmitter operating. If any wrong operation occurs, trainer pushes trainer switch and student transmitter stops sending signal, trainer transmitter controls the aircraft.

## FLYING SAFETY WARNINGS

### Special Symbol Instruction

To use the product safely, please pay attention to the instruction as follows.

Please pay special attention to the symbol as follows:

- ⚠ **Dangers:** If you use it without proper operation, it is possible to hurt you seriously or may even cause death.
- ⚠ **Warnings:** If you use it without proper operation, it may make you or others to hurt badly or may even cause death, and it may cause slight hurt or damage to things.
- ⚠ **Notices:** If you use it without proper operation, it may cause you to hurt slightly or damage things , but it won't hurt you seriously normally.
- ⚠ **Notices:** Children under 14 must be accompanied and instructed by adults!
- ⚠ **Notices:** Turn on the transmitter first, then the receiver. When turning off the system, turn off the receiver first, then the transmitter.
- ⚠ **Notices:** changes or modifications not expressly approved by the party responsible for compliance could void the user's authority to operate the equipment.

**Flying Notice(warning)   ⊘ Forbiddance!   ● Obligation!   ⚠ Warning!**



Do not fly at night , in rain day ,or in strong wind, which will damage the device or plane. This device is not water-proof.



Please check every servo works properly and eliminate any disturbing signals before you play it.

## FEATURES

Computerized transmitter

High Speed, High Resolution, optimized 2.4GHz PCMS 4096

Convenient stick adjustment, make you free usage

Tree-like Multilayer Menu, human oriented design

Excellent white LED backlight, less visual tiredness

132 X 64 FSTN LCD, easy operating buttons

85 model memory

10 point curve(in any X and Y direction edition)

Easy complex curve adjustment

Different Sub trim adjustment sound, easy identify the center

Data transfer function, easy teaching and learning

Multi-function, intuitive data setting, easy checking

Tightness and length of the control stick can be adjusted freely

Excellent touch of the stick movement

3 independence timer, all can be set to count down or increment

## Buttons

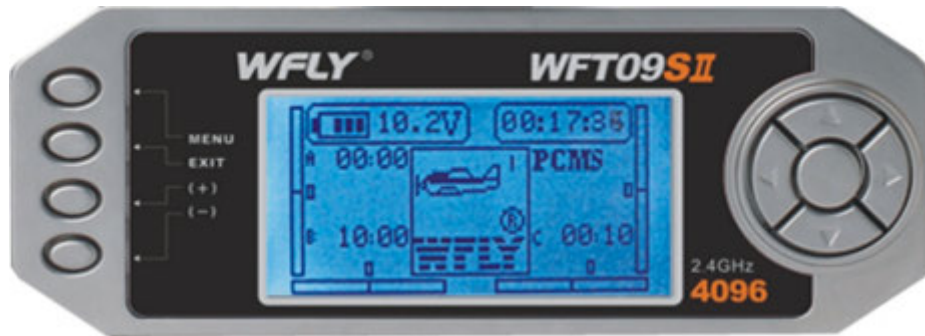

### MENU

Menu button brings you to the function list of the transmitter.

### EXIT

Exit button is to back the previous menu or exit edit.

### +

This button is to increase the value. If you press it for a while, the increasing speed will be faster.

### -

This button is to decrease the value. If you press it for a while, the decreasing speed will be faster.

### Cursor buttons

Move the cursor.

### OK

The button in the middle of the direction buttons is the OK button.

The function is as follows:

To enter the function list.

To enter the edit function.

To back the default for long time press.

## WFLY 2.4GHz Operation instructions

2.4G system can automatically recognize WFLY PCMs and PPM.

### 1. Code matching

#### Description

This function is useful under the situation when the transmitter need to be match and bind with receiver.

#### setting

Enter "normal settings" and choose "advanced", use up and down key to choose coding, press ok to select. The screen will display "OK: Cancel". Set your receiver to coding mode, and use up or down button to choose Ok and then press OK button. The screen will display "Coding wait.." Code matching will be succeeding after the receiver back to normal mode.

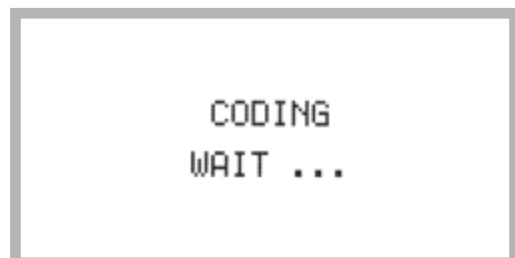
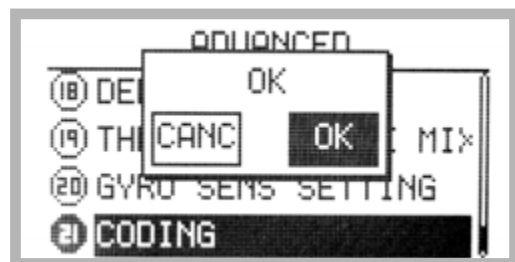
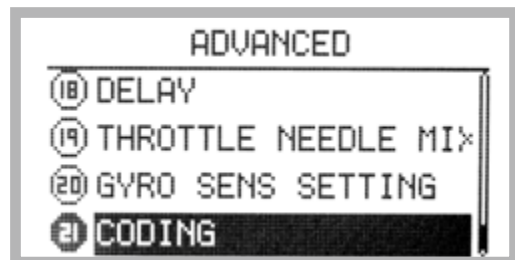
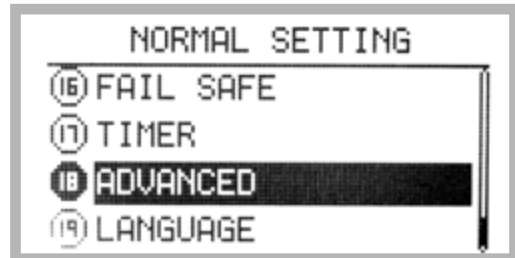

### 2. Fail Safe Setting

A. Power on receiver.

B. Press Set of the module then start transmitter and hold SET for 2 seconds. The green LED flashes, indicating the transmitter enters the code matching status.

C. The Green LED of receiver flashes, the output data of transmitter is the data of Fail Safe Setting of the receiver.

D. Due to the heavy interference or out of normal range, the receiver enters FailSafe. The Red LED of the receiver lights when it is in Fail Safe status.

Adjust the stick head:

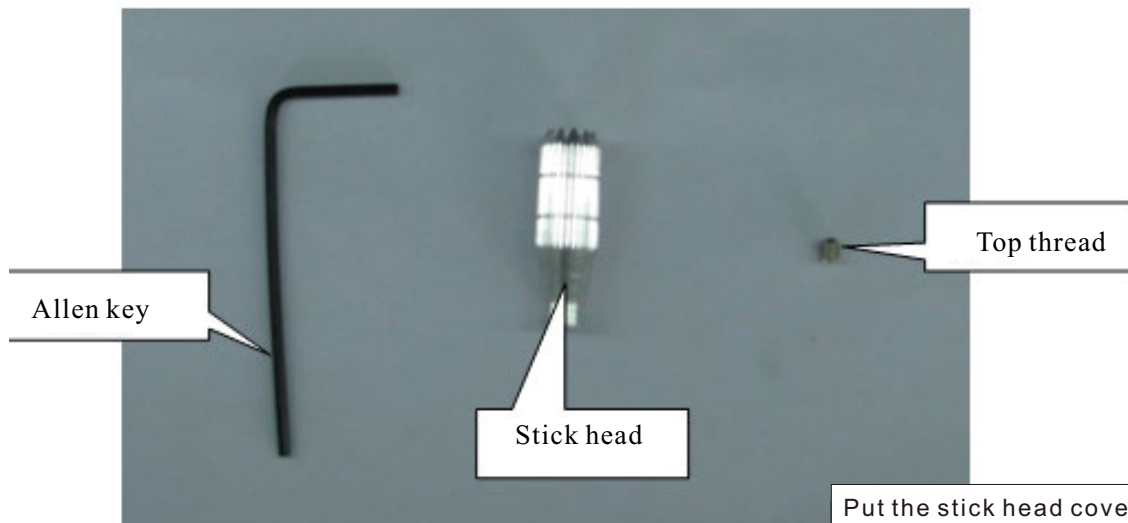

Put the stick head cover the control rod on the left and right sides, don't twist down the stick head to the bottom, and then put top thread with allen key to adjust the height you need.

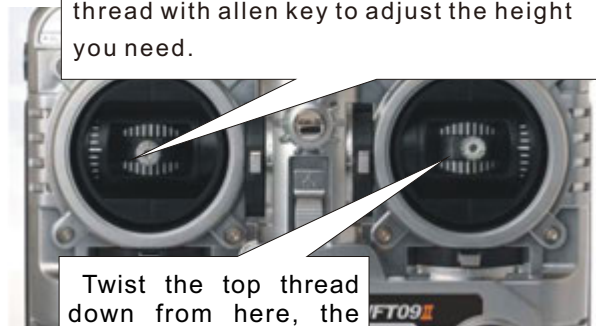

Twist the top thread down from here, the height of the stick head depends on the depth of the top thread.

Adjust the height higher: first make the top thread loose with the allen key, then twist the stick head up, then, make the top thread tighten with allen key, Ok, the stick head was turned up.

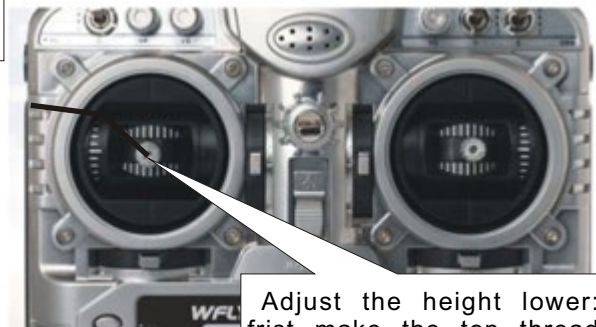

Adjust the height lower: first make the top thread loose with the allen key, then twist the stick head down, then, make the top thread tighten with allen key, Ok, the stick head was turned down.

Steps:

- 1 Put the stick head on the stick.
- 2 Put the top thread in the stick head with allen key.
3. Adjust top thread in the stick head with allen key to fix the height of the stick head.

change the throttle direction of mode1 or 2:

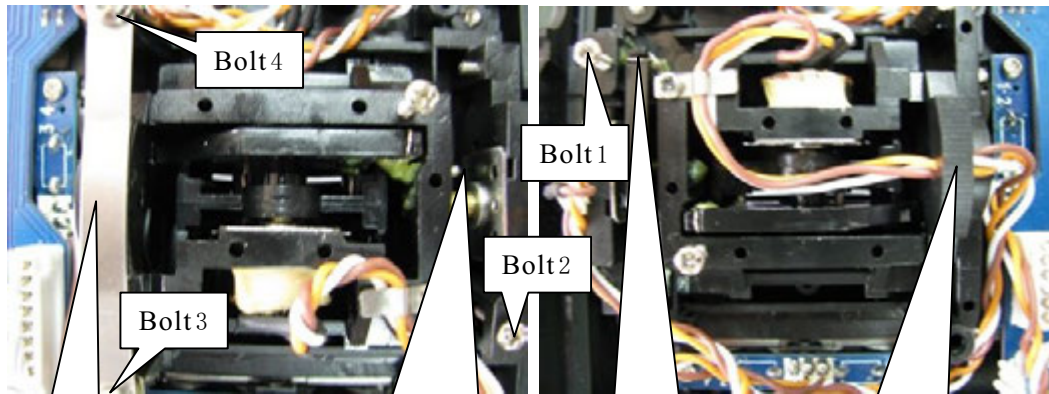

Take the metal chip and the screw down, and put it on the similar position of the right side .

Set up release link and springer, according your habit to adjust the the tightness of screw 2 to adjust the control feeling.

Take repositor and spring down, and put it on the left side of the location of corresponding.then twist bolt 1 down until withstand the adjust nail in case adjust nail will move away.

Put on the metal chip, according your habit to adjust the elasticity of screw 3 and screw 4 to adjust the damp of throttle control feeling.

## HELICOPTER

Press Menu and turn on the transmitter to enter SYS SETTING.  
Select MODEL SETTING, press OK button to select the model type.  
Restart the transmitter after setting.

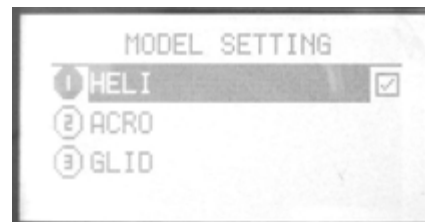
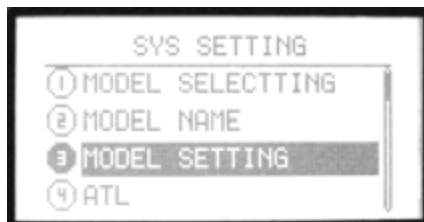

## Editing mode and function introduction

### 1. Opening Screen

Turn on the power switch, the LCD displays as follows.

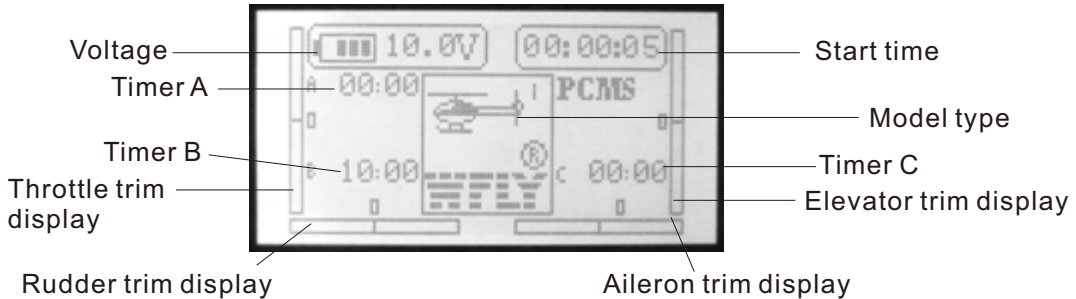

The opening screen displays the voltage, timer, model, aileron, throttle, elevator and rudder state.

Note: Press EXIT you can see the model name.

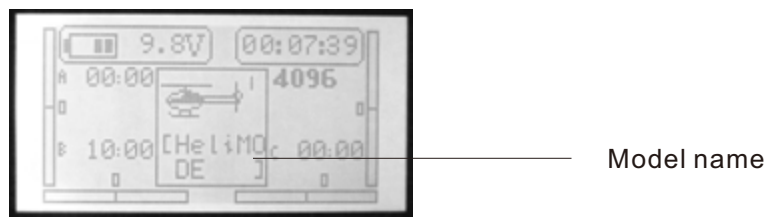

### 2. Menu Screen

There are “Normal setting”, “SYS setting”, “Advanced”.

#### A. Normal setting

Turn on the transmitter, press the menu button, the LCD displays as follows.

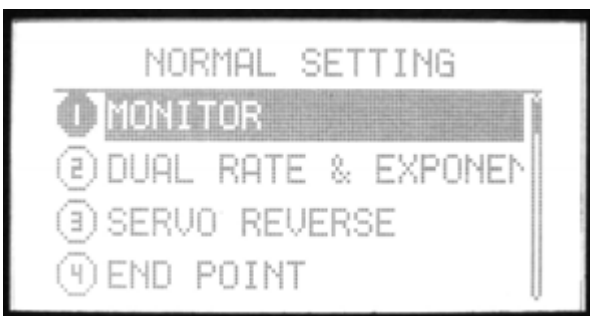

1. MONITOR
2. DUAL RATE & EXPONENTIAL SETTING
3. SERVO REVERSE
4. END POINT
5. SUB TRIM
6. SWASH PARAM SETTING
7. AUXILIARY CHANNELS
8. THROTTLE CURVE SETTING
9. PITCH CURVE SETTING
10. REVOLUTION MIXING
11. TRIM STEP SETTING
12. THROTTLE CUT SETTING
13. FLY MODEL SWITCH
14. THROTTLE HOLDING SETTING
15. FAIL SAFE
16. TIMER
17. ADVANCED
18. LANGUAGE

#### Setting method:

1. Use direction button to select the editing part, use up/down buttons to select function item. Left/right direction button to turn page.
2. Press OK button to enter submenu. The submenu function is in the next chapter.
3. Press EXIT button to back previous menu and the data is set automatically.

## B. SYS SETTING

Press Menu and turn on the power switch, the LCD displays as follows.

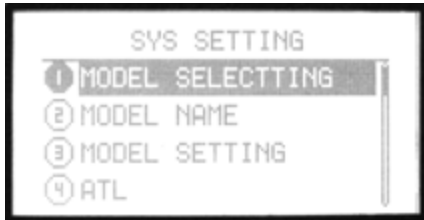

1. MODEL SELECTING
2. MODEL NAME
3. MODEL SETTING
4. ATL
5. MODULATION SETTING
6. SWASH SELECT
7. STICK SETTING
8. ADJUSTMENT
9. REST SETTING
10. SEND DATA
11. RECEIVE DATA
12. SOUND
13. CONTRAST SETTING
14. ENGINEER MODEL
15. ABOUT
16. LANGUAGE

Setting method:

1. Use direction button to select the editing part, use up/down buttons to select function item. Left/right direction button to turn page.

2. Press OK button to enter submenu. The submenu function is in the next chapter.

3. Press EXIT button to back previous menu and the data is set automatically.

## C. ADVANCED

1. Enter "NORMAL SETTING", use right direction button to turn page, select "ADVANCED".

Press OK button to enter.

Setting method:

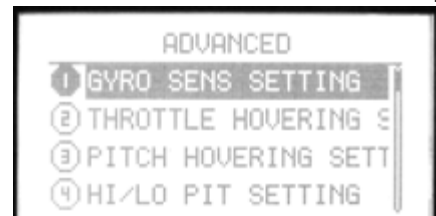

1. Use direction button to select the editing part, use up/down buttons to select function item. Left/right direction button to turn page.

2. Press OK button to enter submenu. The submenu function is in the next chapter.

3. Press EXIT button to back previous menu and the data is set automatically.

## SYS SETTING

### 1. Model selectting

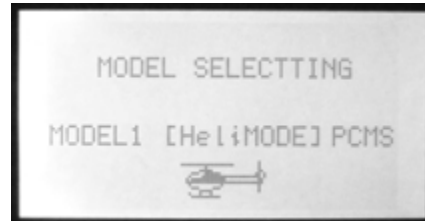
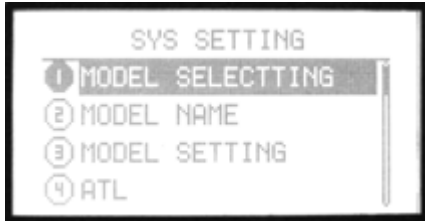

There are 85 helicopter models. You can select any one to set.

#### Setting Method:

Press Menu and turn on the transmitter to enter "SYS SETTING"  
Use up/down button to select "**Model selectting**", OK button is to enter editing.

#### Steps:

1. Use up/down direction button to select the model.
2. Press OK button to select.
3. Press EXIT after setting.

## 2. Model name

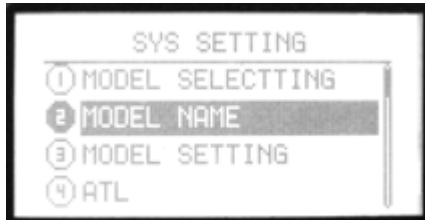

This function is to make new names by users.

### Setting Method:

Press Menu and turn on the transmitter to enter "SYS SETTING"  
Use up/down button to select "**Model name**", OK button is to enter editing.

### Steps:

1. You can edit the underlined letter.
2. Press OK button to choose the word you like.
3. Press EXIT after setting.

### 3. Model setting

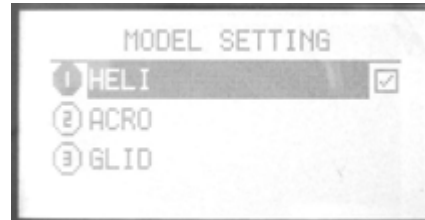
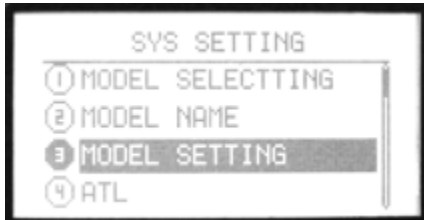

You can select the model type. There are three type: HELI, ACRO, GLID.

#### Setting Method:

Press Menu and turn on the transmitter to enter “SYS SETTING”  
Use up/down button to select “**Model setting**”, OK button is to enter editing.

#### Steps:

1. Use up/down direction button to select the model type.
2. Press OK button to confirm.
3. Press EXIT after setting.

## 4. ATL

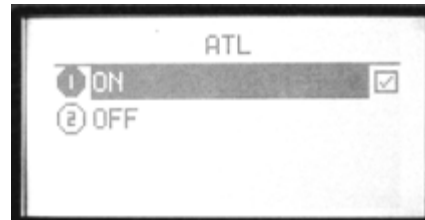
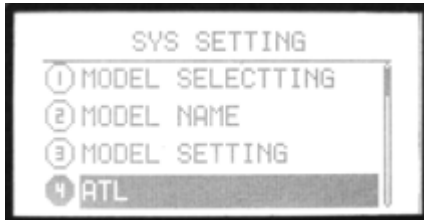

Adjustable travel limit (ATL) makes throttle trim effective only at low throttle, disabling the trim at high throttle. This prevents pushrod jamming due to idling trim changes. This function defaults to ON. If you are not using channel 3 for throttle, you may want trim operation the same as on all other channels. To do so, set ATL to OFF.

### Setting Method:

Press Menu and turn on the transmitter to enter "SYS SETTING"  
Use up/down button to select "**ATL**", OK button is to enter editing.

### Steps:

1. Use direction buttons to select the editing part.
2. Press +/- button to set ATL function.
3. Press EXIT after setting.

## 5.Modulation setting

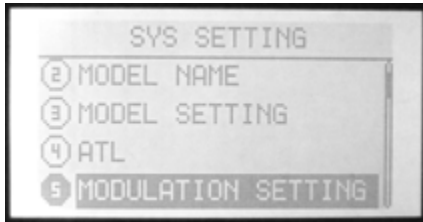

Because of the different receiver modulation PPM/PCMS1024 /2.4G PCMS4096, the transmitter should be accordance with the receiver modulation.

### Setting Method:

Press Menu and turn on the transmitter to enter “SYS SETTING” Use up/down button to select “**Modulation setting**”, OK button is to enter editing.

### Steps:

1. Use direction buttons to select the editing part.
2. Press OK button to confirm. Restart the transmitter and it works.

## 6.RF setting

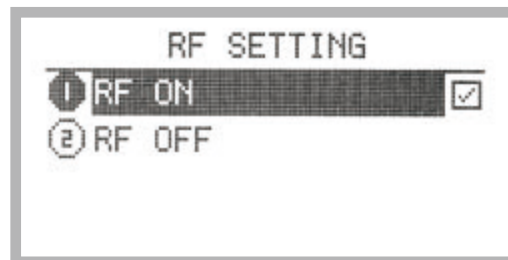
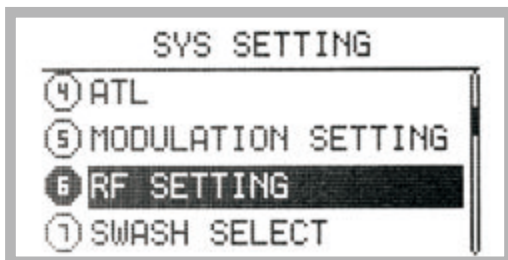

### Description

The user can turn off the RF module during emulation to minimize power consumption.

### Setting method

Press menu button during power on to enter system setting menu, use up/down button to select "RF setting". press OK button to enter setting interface.

as shown on the picture, choose ON or OFF and press OK. Reboot the transmitter to active.

## 7. Swash select

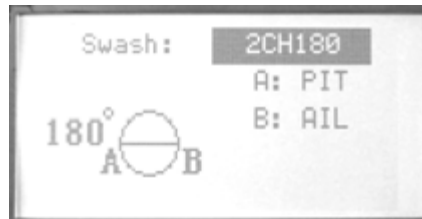
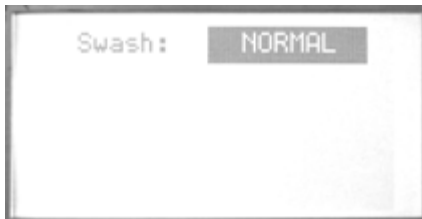
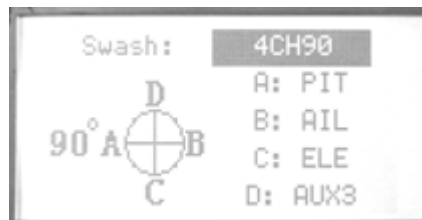
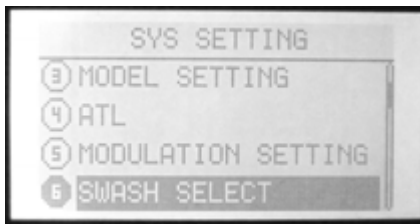

There are 6 kinds of swash. You can select the swash you preferred. If you use 120 degree CCPM helicopter, the servos will realize mix function automatically. Please select the swash according to your helicopter swash type.

- 1 servo (not CCPM, normal helicopter)
- 2 servos (180 degree)
- 3 servos (90, 120, 140 degree)
- 4 servos (90 degree)

### Setting Method:

Press Menu and turn on the transmitter to enter "SYS SETTING"  
Use up/down button to select "**Swash select**", OK button is to enter editing.

### Steps:

1. Use direction button to select the editing part.
2. Press +/- button **TO CHOOSE THE SWASH**
3. Press EXIT after setting.

## 8. Stick setting

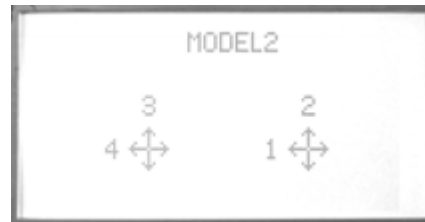
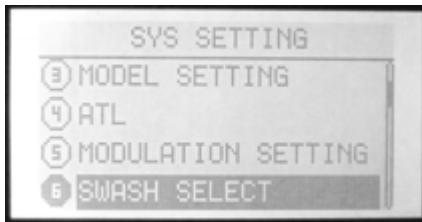

There are 4 kinds of model, you can use up/down direction button to select the model you preferred.

- 1-aileron
- 2-elevator
- 3-throttle
- 4-rudder

### Setting Method:

Press Menu and turn on the transmitter to enter "SYS SETTING"  
Use up/down button to select "**Stick setting**", OK button is to enter editing.

### Steps:

1. Use direction button to select the editing part.
2. Press up/down button to choose Stick mode.
3. Press EXIT after setting.

## 9.Adjustment

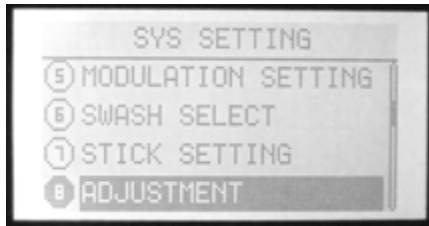

This function is to set the central, high and low point of four sticks when users changed the mode I or II by themselves.

### Setting Method:

Press Menu and turn on the transmitter to enter "SYS SETTING"  
Use up/down button to select "**ADJUSTMENT**", OK button is to enter editing.

### Steps:

1. Use direction button to select the editing part. Take the aileron adjustment for example.
2. Make the stick in the mid-point location. Press OK button to select any stick you want to adjust.
3. Select into the Figure 2, when the "center" highlights, press the "ok" button directly (the mid-point has been adjusted), then enter the high adjust.
4. The "high" highlights, take the stick gently in the right side (throttle /elevator in the top, aileron / rudder in the right),press "ok" button ( the max adjust is OK), enter the low adjustment.
- 5.The "low" highlights, take the stick gently in the left side (throttle /elevator in the bottom, aileron / rudder in the left),press "ok" button (the min adjust is OK).
6. Press OK or RESET to confirm the record or reset.
7. If the record is wrong, press OK will back to step 3.

## 10.Reset setting

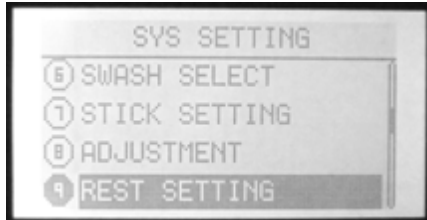

This function is to back default.

### Setting Method:

Press Menu and turn on the transmitter to enter "SYS SETTING"  
Use up/down button to select "**Reset setting**", OK button is to enter editing.

### Steps:

1. Use direction button to select the editing part.
2. Press +/- button to back default.
3. Press EXIT after setting.

## 11. Send data

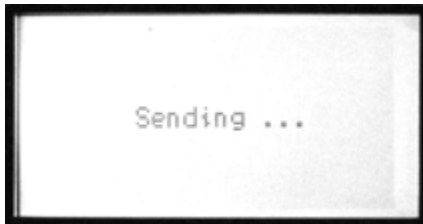
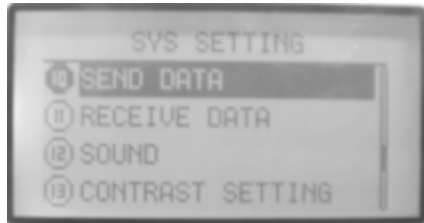

Two transmitters (WFT09S) can copy data by a trainer cable/data transfer cable. This function together with the next function “Receive data” can realize the data copy.

### Setting Method:

Press Menu and turn on the transmitter to enter “SYS SETTING” Use up/down button to select “**Send data**”, OK button is to enter editing.

### Steps:

1. Select the model data you want to send out.
2. Press OK to send.

## 12.Receive data



Two transmitters (WFT09S) can copy data by a trainer cable/data transfer cable. This function together with the previous function “Send data” can realize the data copy.

### Setting Method:

Press Menu and turn on the transmitter to enter “SYS SETTING” Use up/down button to select “**Receive data**”, OK button is to enter editing.

### Steps:

1. Press OK to receive data.
2. Restart the transmitter after receiving the data and it works.

## 13.Sound

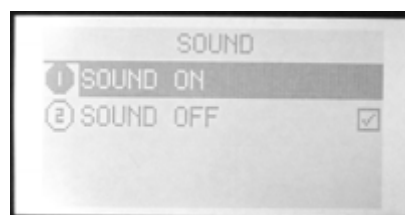
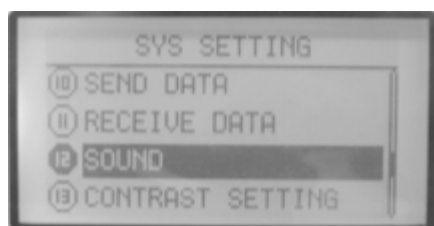

This function is to select the sound ON and OFF.

### Setting Method:

Press Menu and turn on the transmitter to enter "SYS SETTING"  
Use up/down button to select "SOUND", OK button is to enter editing.

### Steps:

1. Use +/- button to select ON and OFF.
2. Press OK button to confirm.
3. Press EXIT after setting.

## 14. Contrast setting

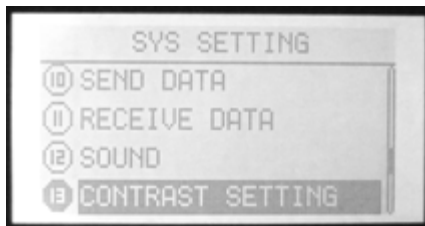

This function is to adjust the LCD brightness by increasing or decreasing the contrast value.

### Setting Method:

Press Menu and turn on the transmitter to enter "SYS SETTING"  
Use up/down button to select "**Contrast setting**", OK button is to enter editing.

### Steps:

1. Use +/- button to increase or decrease the value.
2. Press OK button for a while is to back default.
3. Press EXIT after setting.

## 15.About



This item shows the Version of WFLY radio.

## Language

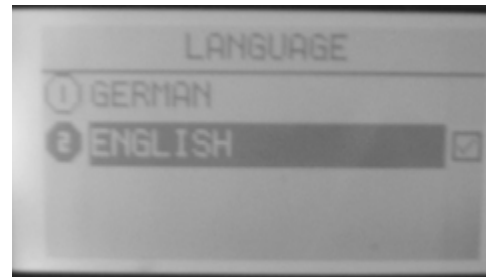
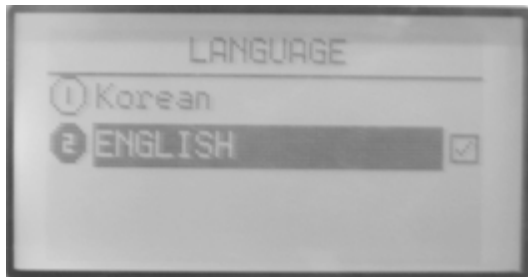
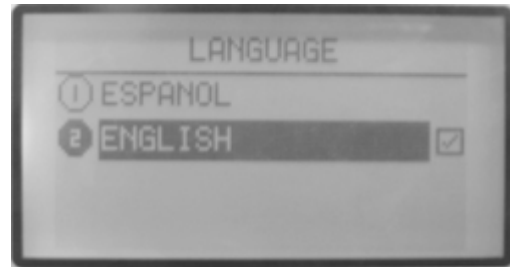
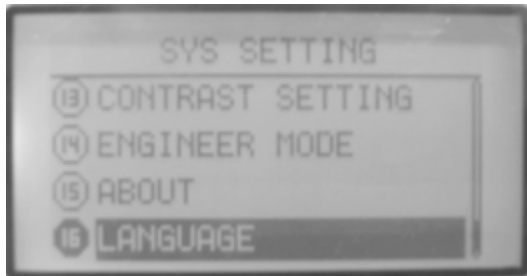

This function is to select the language. The selection is as shown in the picture, if only English or Chinese menu, the function is not exist.

## NORMAL SETTING(helicopter)

### 1. MONITOR

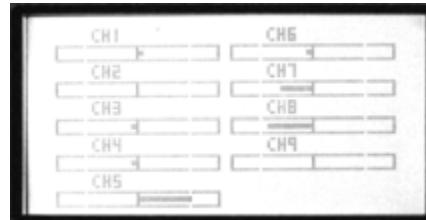
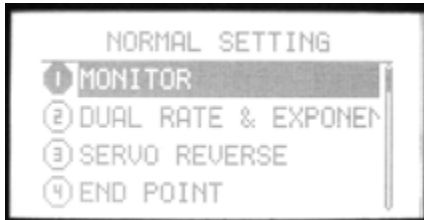

Monitor shows the servos' movement situation.

In PCMS, this function is to describe the 9 channels output.

In PPM, this function is to describe the first 8 channels output.

#### Setting Method:

Press menu button, enter system setting, the first function is the monitor.

## 2. DUAL RATE & EXPONENTIAL SETTING

### (1). AIL

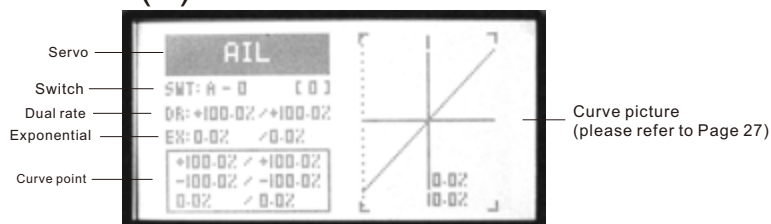
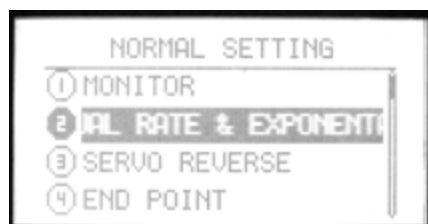

### (2). ELE

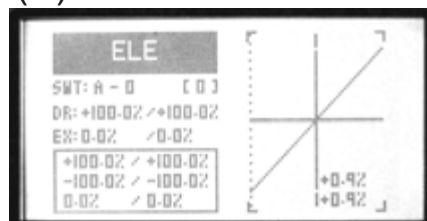

### (3). RUD

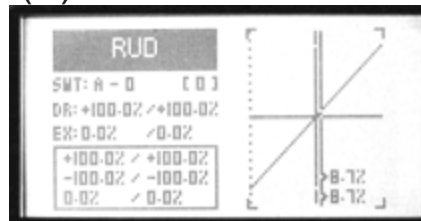

Dual rate is to adjust aileron, elevator and rudder travel range. The range is between 0%-120%.

Exponential setting is to adjust aileron, elevator and rudder sensitivity when the sticks are around the middle. The range is between -100% to +100%.

### Setting Method:

1. Select channel  
Aileron, elevator and rudder are selectable. Press +/- buttons to select channel, OK button to finish setting.
2. Set the switch and its position(0,1,2)  
Press direction button to select "SWT", edit it. +/- buttons can select function switch(A-F).  
After selecting the function switch, press right direction button to enter the switch position setting, use +/- buttons to set.
3. Set dual rate  
Press direction button to select "D/R", edit it. Edit one or two parameter.  
+/- buttons can increase or decrease the value.  
Press the OK button is to back default.
4. Set exponential  
Press direction button to select "EX". Exponential can adjust aileron, throttle and rudder sensitivity as the stick at the middle.
5. Set curve point (normal/advanced)  
The box under "EX" shows the curve points.  
Select "Curve setting" in More setting function list.  
Please refer to Page 27 for detail curve setting.
6. Press EXIT after all the values are finished setting.

### 3. SERVO REVERSE

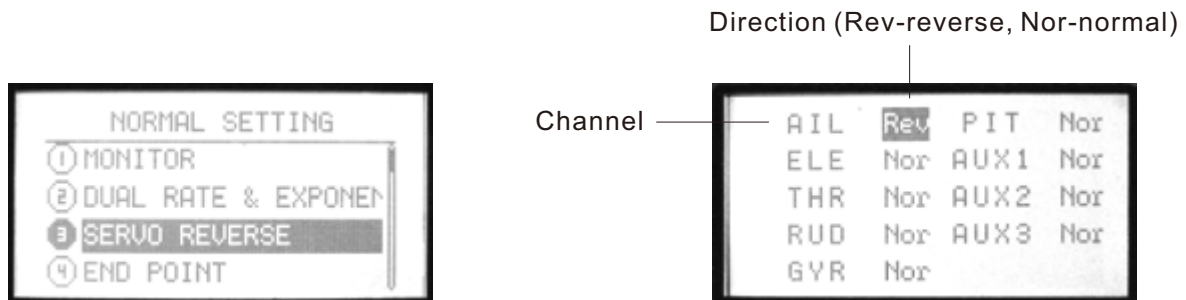

This function is to change the direction of the servos movement.

#### Setting Method:

Use up/down button to select **Servo reverse**, OK button is to enter editing.

#### Steps:

1. Use direction buttons to select editing part.
2. Use +/- button or OK button to switch the servo movement direction.
3. Press EXIT after setting.

## 4. END POINT



It is to adjust the end of individual servo's travel. The range is from 0% to 120%.

### Setting Method:

Use up or down button to select **End point**, OK button is to enter editing.

### Steps:

1. Use direction buttons to select editing part.
2. Use +/- button or OK button to set the travel value. Press OK for a while backs to default.
3. Press EXIT after setting.

## 5. SUB TRIM

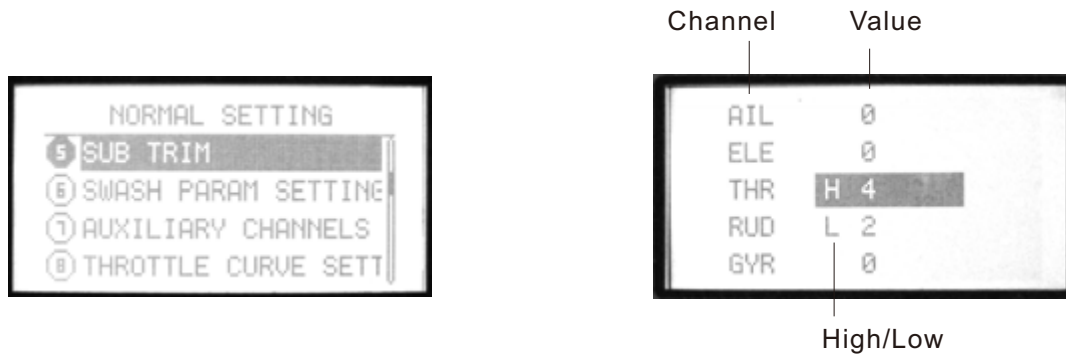

Sub trim makes small changes or corrections to the neutral position of each servo. Range is -120 to +120, default setting is 0.

We recommend that you center the digital trims before making Sub trim changes, and that you try to keep all of the Sub trim values as small as possible. Otherwise, when the Sub trims are large values, the servo's range of travel is restricted on one side.

### Setting Method:

Use up or down button to select Sub trim, OK button is to enter editing.

### Steps:

1. Use direction buttons to select editing part.
2. Use +/- button or OK button to set the trim value. Press OK for a while backs to default.
3. Press EXIT after setting.

## 6. SWASH PARAM SETTING

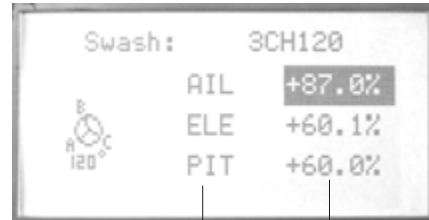
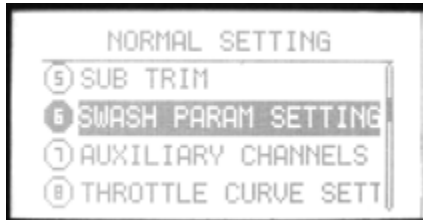

Effecton  
direction      Value

This function is to adjust the aileron, elevators and pitch travel range of swash mixing mode.

### Setting Method:

Use up or down button to select **Swash param setting**, OK button is to enter editing.

### Steps:

1. Use direction buttons to select editing part.
2. Use +/- button to set the travel. Press OK button for a while is to back default(60%).
3. Press EXIT after setting.

## 7. AUXILIARY CHANNELS SETTING

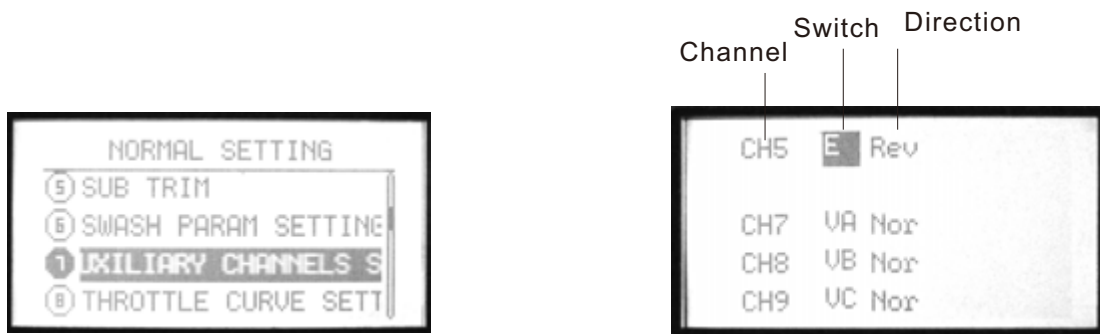

This function is for channel 5 to channel 9 function setting.

### Setting Method:

Use up or down button to select Swash param setting, OK button is to enter editing.

### Steps:

1. Use direction buttons to select editing part.
2. Use +/- button to set the switches or knobs. The switches can be set from A to F, the knobs can be set as VA, VB, VC, VL, VR or none(-).
3. Use left or right direction button to set normal or reverse direction of every channel.
4. Press EXIT after setting.

8. THROTTLE CURVE SETTING

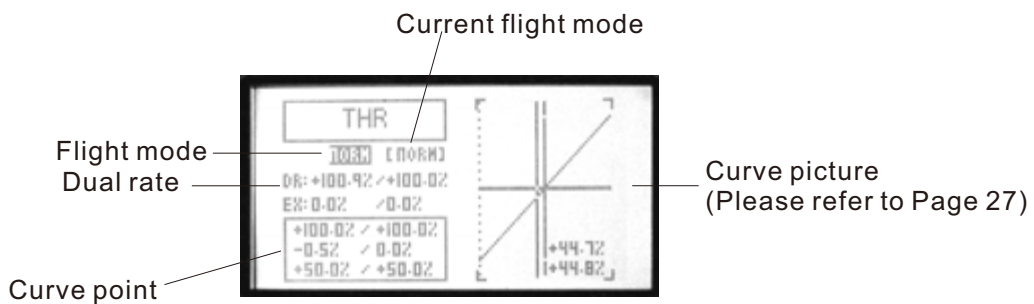
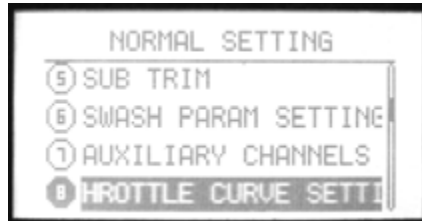

Throttle curve, together with the throttle stick, can be adjusted properly to maximize engine performance at a particular pitch setting.

There are two kinds of curve setting, normal (7 points curve), advanced (2-10 points curve), the range is between 0%-120%. The transmitter can set the following curves: NORM, IDLE1, IDLE2, IDLE3.

Normal curve is based on hovering, to maximize engine performance at a particular pitch setting.

Idle curve is for engine proper work in a 3D flight, with a good match between throttle and pitch.

**Setting Method:**

Use up/down button to select **Throttle curve setting**, OK button is to enter editing.

**Steps:**

1. Flight(NORM IDLE1 IDLE2 IDLE3)  
Use direction buttons to select editing part. Use +/- button to select one curve.
2. Set Dual rate  
Use direction button to select "D/R" and edit (one or two values can be set separately or together). Press +/- button for seconds can increase or delete the value. Press OK button for seconds is to back default(60%).
3. Curve point setting(Normal/Advanced)  
The below pane shows the points curve.  
Select "Curve setting" in "SYS setting", choose the curve.  
For detail curve setting method please refer to Page 27.
4. Press EXIT after setting.

### 9. PITCH CURVE SETTING

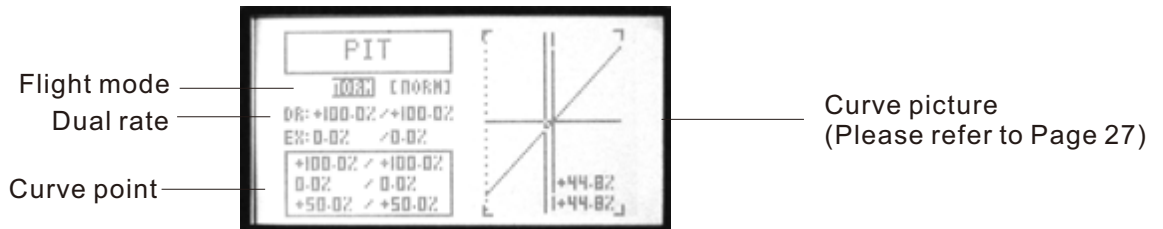
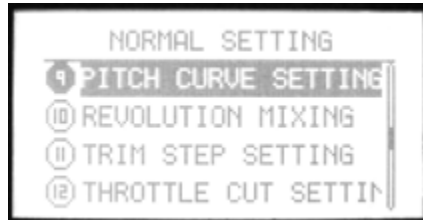

Pitch curve, together with the throttle stick, can be adjusted properly to maximize engine performance at a particular pitch setting.

There are two kinds of curve setting, normal (7 points curve), advanced (2-10 points curve), the range is between 0%-120%. The transmitter can set the following curves: NORM, IDLE1, IDLE2, IDLE3.

Normal curve is based on hovering, to maximize engine performance at a particular pitch setting.

Idle curve is for engine proper work in a 3D flight, with a good match between throttle and pitch.

**Setting Method:**

Use up/down button to select **PITCH CURVE SETTING**, OK button is to enter editing.

**Steps:**

1. Flight(NORM IDLE1 IDLE2 IDLE3)  
Use direction buttons to select editing part. Use +/- button to select one curve.
2. Set Dual rate  
Use direction button to select "D/R" and edit (one or two values can be set separately or together). Press +/- button for seconds can increase or delete the value. Press OK button for seconds is to back default(60%).
3. Curve point setting(Normal/Advanced)  
The below pane shows the points curve.  
Select "Curve setting" in "SYS setting", choose the curve.  
For detail curve setting method please refer to Page 27.
4. Press EXIT after setting.

## 10. REVOLUTION MIXING

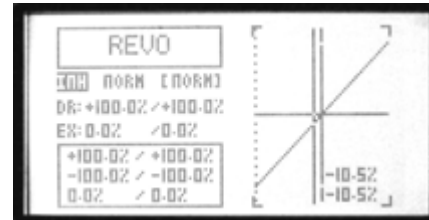

This curve mix adds opposite rudder input to counteract the changes in torque when the speed and collective pitch of the blades is changed.

### Setting Method:

Use up/down button to select **Revolution mixing**, OK button is to enter editing.

### Steps:

1. Flight(NORM IDLE1 IDLE2 IDLE3)  
Use direction buttons to select editing part. Use +/- button to select one curve.
2. Set Dual rate  
Use direction button to select "D/R" and edit (one or two values can be set separately or together). Press +/- button for seconds can increase or delete the value. Press OK button for seconds is to back default(60%).
3. Curve point setting(Normal/Advanced)  
The below pane shows the points curve.  
Select "Curve setting" in "SYS setting", choose the curve.  
For detail curve setting method please refer to Page 27.
4. Press EXIT after setting.

## 11. TRIM STEP SETTING

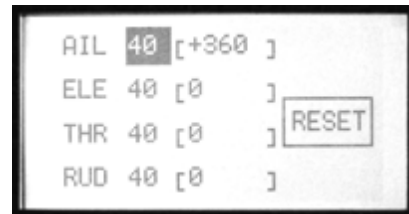
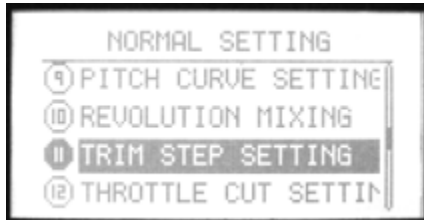

This function is to change the rate at which the trim moves when the TRIM LEVER is activated. The range is from 1 to 250. Generally larger trim steps are for models with larger control throws or for first flights to ensure sufficient trim to properly correct the model. Smaller trim steps are later used to allow very fine adjustments in flight.

### Setting Method:

Use up/down button to select **Trim step setting**, OK button is to enter editing.

### Steps:

1. Use direction buttons to select editing part.
2. Use +/- button to adjust the size of the step,
3. Repeat as desired for other channels.
3. Press EXIT after setting.

## 12. THROTTLE CUT SETTING

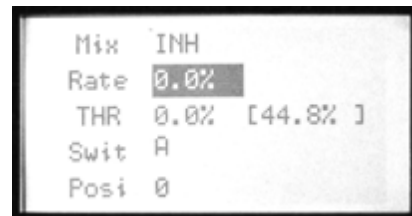
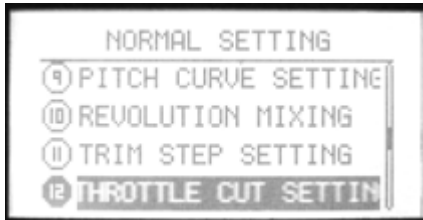

This function is to shut off the engine at the end of a flight. The engine can be stopped with one touch of any switch, eliminating the need to move the trim to kill the engine and then readjust prior to each flight. The helicopter THR CUT includes an ON/OFF throttle position (normally a little above idle). You must move the THROTTLE STICK back below the set point before the THR-CUT function can be reset, to avoid sudden engine acceleration.

### Setting Method:

Use up/down button to select **Throttle cut setting**, OK button is to enter editing.

### Steps:

1. Use direction buttons to select editing part.
2. Use +/- button to turn on/off throttle cut function.
3. Use +/- button to set the throttle rate and trim (range is between +45% to -45%).
4. Use +/- button to set the position.
5. Press EXIT after setting.

### 13. FLY MODEL SWITCH

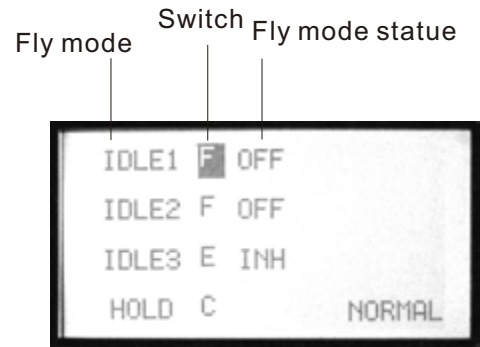
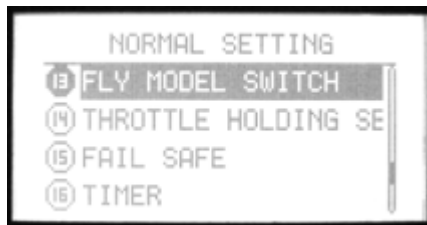

This function is to select the flight mode.

#### Setting Method:

Use up/down button to select **Fly model switch**, OK button is to enter editing.

#### Steps:

1. Use direction buttons to select editing part.
2. Use +/- button to set every fly model.
3. Use +/- button to set fly model ON/OFF position.
4. Press EXIT after setting.

## 14. THROTTLE HOLDING SETTING

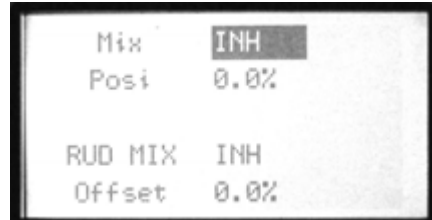

This function can make the throttle servo operating at a low speed position at the end of a flight. The range is between -75% and +75%.

User can set the mix function with rudder under the throttle holding state and the mix rate (offset).

This function switch can be found in “**Fly model switch**”.

### Setting Method:

Use up/down button to select **Throttle holding setting**, OK button is to enter editing.

### Steps:

1. Use direction buttons to select editing part.
2. Use +/- button to active or inhibit the mix function.
3. Use +/- button to set the throttle holding position.
4. Use +/- button to active or inhibit the rudder mix.
5. Use +/- button to set the mix rate (offset). Press OK button for seconds can back to default.
6. Press EXIT after setting.

## 15. FAIL SAFE

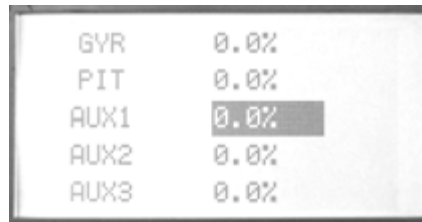
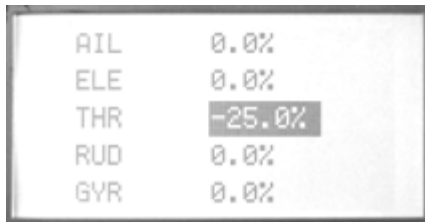
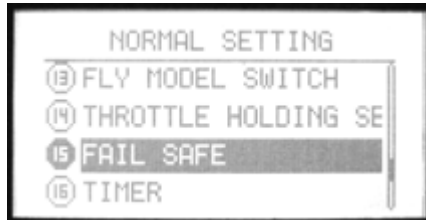

This function is to set responses in case of loss of signal or low RX battery.

### Setting Method:

Use up/down button to select **Fail safe**, OK button is to enter editing.

### Steps:

1. Use direction buttons to select editing part.
2. Use +/- button to select "hold" or "0.0%"
3. Press OK button to confirm the current parameter.
4. Press EXIT after setting.

## 16. TIMER

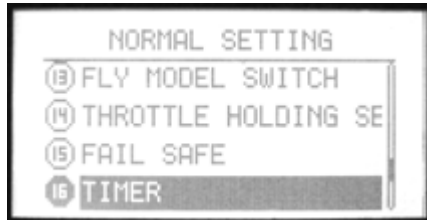

The flight time of every helicopter is different according to the different tank of fuel, engine, ESC, etc. Timer function can alarm you to land before the fuel lacks.

The transmitter can set 3 timers (A, B, C). The longest time can be set as MM99SS59. The countdown timer can alarm user before 10 minutes. The alarm will become 2S/1S from 1S/1S in the last 10 seconds. When the countdown timer is 0, the time will add up.

The timer can be seen in the opening screen. Any switch can be set to control the begin and stop of the time.

### Setting Method:

Use up/down button to select **TIMER**, OK button is to enter editing.

### Steps:

1. Use direction buttons to select editing part.
2. Set timer. WFT09S can set 3 timers (A, B, C).
3. Use +/- button to set MM..SS... Press OK button for seconds can back to default.
4. Use +/- button to set model.
5. Use +/- button to set control(CTRL).
6. Use +/- button to set the position which can active this function.
7. Press EXIT after setting.

## 17. ADVANCED

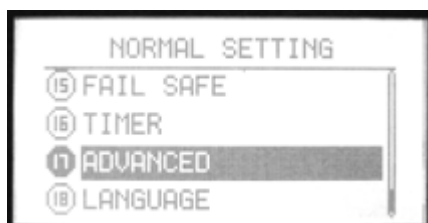

To realize an idea fly, there are 21 advanced function in **ADVANCED**.

### Setting Method:

Use up/down button to select **ADVANCED**, OK button is to enter editing. +/- button can turn page.

About each advanced functions please read the following pages.

## ADVANCED FUNCTION INTRODUCTION

### (1). GYRO SENS SETTING

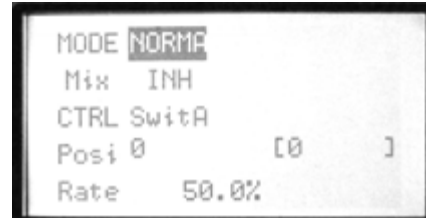

User can adjust the gyro sensitivity by transmitter, AVCS gyro (GY) and normal gyro (STD).

Gyro sensitivity switch plug should plug in the fifth channel of receiver. The auxiliary channel CH 5 won't have any function now. User can set sensitivity switch from switch A to F, and also fly model (NORM, IDLE1,2,3).

#### Setting Method:

Use up/down button to select **GYRO sens setting**, OK button is to enter editing.

#### Steps:

1. Use direction buttons to select editing part.
2. Use +/- button to set fly model at "MODE".
3. Use +/- button to active or inhibit "Mix". Press OK button for seconds can back default.
4. Use +/- button to set control switch at "CTRL".
5. Use +/- button to set the switch position when the function is active.
6. Use +/- button to set the "Rate". Press OK button for seconds can back default.
7. Press EXIT after setting.

## (2). THROTTLE HOVERING SETTING

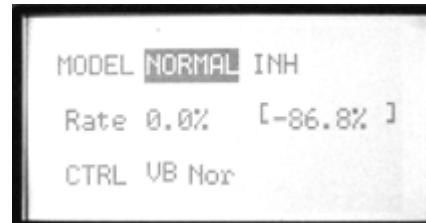

Throttle hovering setting is fine-tuning adjustments for the throttle, affecting performance only around the center point and only in the normal condition. This function can set knob VA/VB/VC to control, turn right the rotor speed becomes faster, turn left the rotor speed becomes slower.

Rotor speed changes caused by temperature, humidity, altitude or other changes in flying conditions are easily accommodated.

### Setting Method:

Use up/down button to select **Throttle hovering setting**, OK button is to enter editing.

### Steps:

1. Use direction buttons to select editing part.
2. Use +/- button to select "MODEL".  
Use +/- button to active or inhibit this function.
3. Use +/- button to set "Rate". Press OK button for seconds can back default.
4. Use +/- button to set control switch.
5. Press EXIT after setting.

### (3). PITCH HOVERING SETTING

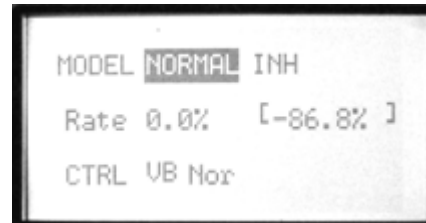

Pitch hovering setting is fine-tuning adjustments for the pitch, affecting performance only around the center point and only in the normal condition.

This function can set knob VA/VB/VC/VR/VL to control, turn right the rotor speed becomes faster, turn left the rotor speed becomes slower.

Rotor speed changes caused by temperature, humidity, altitude or other changes in flying conditions are easily accommodated.

#### Setting Method:

Use up/down button to select **Pitch hovering setting**, OK button is to enter editing.

#### Steps:

1. Use direction buttons to select editing part.
2. Use +/- button to select "MODEL".  
Use +/- button to active or inhibit this function.
3. Use +/- button to set "Rate". Press OK button for seconds can back default.
4. Use +/- button to set control switch.
5. Press EXIT after setting.

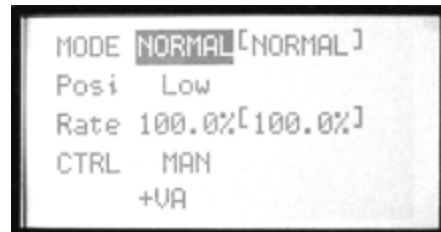
**(4). HI/LO PIT SETTING**

This function is to set the high and low pitch position at different flying modes.

This function can set knob VA/VB/VC/VR/VL to control or controlled by user "CTRL MAN".

IF "CTRL MAN", the pitch is set by "Rate", the range is between 60%-100%.

**Setting Method:**

Use up/down button to select **HI/LO PIT setting**, OK button is to enter editing.

**Steps:**

1. Use direction buttons to select editing part.
2. Use +/- button to select "MODEL".  
Use +/- button to active or inhibit this function.
3. Use +/- button to **S**et the "Pos", low or high.
4. Use +/- button to set "Rate". Press OK button for seconds can back default.
5. Use +/- button to set control switch.
6. Press EXIT after setting.

## (5). TRIM OFFSET SETTING

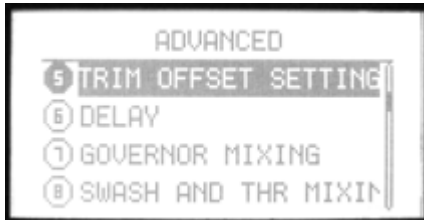

This function is to adjust the servo trim at hovering state. This function is used to automatically change the trim of a helicopter, for example, when transitioned from hover to flying at high speed. A clockwise-rotation rotor helicopter tends to drift to the right at high speed, so an aileron offset may be applied to offset the helicopter to the left.

The necessary elevator offset varies with model geometry, so it must be determined by noting collective pitch changes at high speed.

The rudder offset is affected by both revolution mixing and trim lever movement while in the offset function.

### Setting Method:

Use up/down button to select **Trim offset setting**, OK button is to enter editing.

### Steps:

1. Use direction buttons to select editing part.
2. Use +/- button to active or inhibit "Mix".
3. Use +/- button to **S**et the control switch "CTRL".
4. Use +/- button to set the control switch position "Pos".
5. Use +/- button to set the channel, eg: aileron, elevator, etc.
6. Use +/- button to set the mix rate "Rate". Press OK button for seconds can back default.
7. Press EXIT after setting.

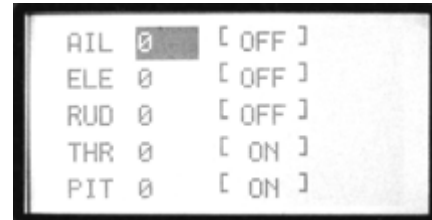
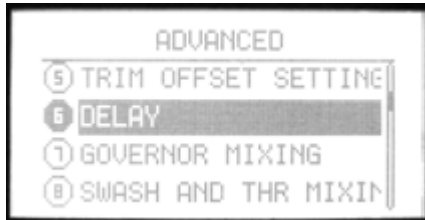
**(6). DELAY**

This function is to delay the aerobatics or throttle cut when the helicopter is in the air so that to avoid the big trim change. The Delay function provides a smooth transition between the trim positions whenever OFFSET, REVO. MIXING, or THROTTLE HOLD functions are turned on and off.

**Setting Method:**

Use up/down button to select **DELAY**, OK button is to enter editing.

**Steps:**

1. Use direction buttons to select editing part.
2. Use +/- button to active or inhibit **T** his function. Press OK button for seconds can back default.
3. Press EXIT after setting.

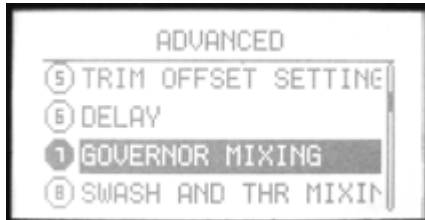
**(7). GOVERNOR MIXING**

This function is to set the governor.  
The Governor mixing function is used to adjust the Governor speed settings from the transmitter.

**Setting Method:**

Use up/down button to select **Governor mixing**, OK button is to enter editing.

**Steps:**

1. Use direction buttons to select editing part.
2. Use +/- button to active or inhibit "Mix".
3. Use +/- button to **S**et the **M**ix rate "Rate". Press OK button for seconds can back default.
4. Use +/- button to set the control switch "CTRL".
5. Use +/- button to set the channel and its direction.
6. Press EXIT after setting.

## (8). SWASH AND THR MIXING

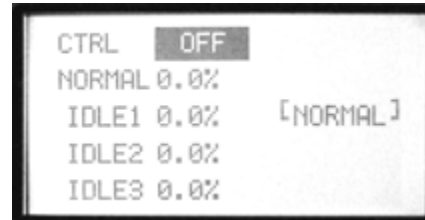

This function is to adjust throttle and pitch mix function.

### Setting Method:

Use up/down button to select **Swash and THR mixing**, OK button is to enter editing.

### Steps:

1. Use direction buttons to select editing part.
2. Use +/- button to active or inhibit "Mix".
3. Press EXIT after setting.

## (9). CURVE SETTING

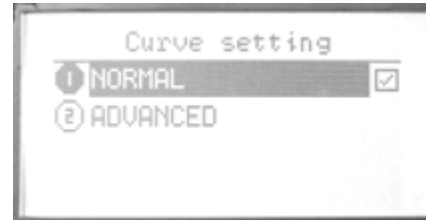
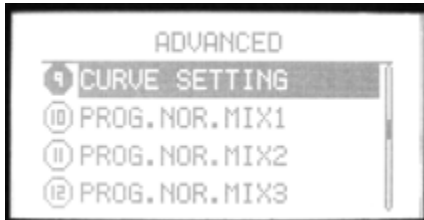

There are 2 kinds of setting, Normal and Advanced.

### 1. Setting introduction

Curve setting is one of the functions of WFT09S. We will make detail description here. You can refer to this detail description for the other functions which relates to the curve setting.

There are two kinds of curve setting mode: normal setting and advanced setting.

Normal setting: 7 points curve setting. You can set the curve by set the 7points value.

Advanced setting: you can add or delete the curve point.

Advanced curve can be added at most 10 points, at least 2 points. You can not only set the value of each point, but also the position of each point.

### 2. Setting method

Turn on the transmitter, press menu, find "More setting", select "curve setting".

There are two modes: normal, advanced.

Normal curve setting: 7 points curve setting. You can edit the curve point in the left pane.

1. Use left/right direction button to select the editing point. The curve point is marked by a dashed line.

2. Use +/- button to set the value. Press OK button for a while can back to default. You can set the 7 points.

3. Press EXIT after setting.

Advanced curve setting: User can add or delete the curve point. D/R curve has 10 points and every point can be set. Press +/- button for seconds can add/delete curve point. It can at most add to 10 points and delete to 2 points.

When selecting one point, use left/right button to choose the point you want to edit, press OK button to enter editing.

Active the cursor, use up/down direction button to set the left value in the pane, use left/right direction button to set the right value in the pane.

The black cursor is the editing part, which is marked by a dashed line.

### **3. The operation method Of increasing、decreasing、moving the curve points to WFT09S**

#### **(1) Increase the curve point**

Open the transmitter entre into No,17 advanced setting→confirm→select No.9 curve setting→ select No.2:Advanced→confirm→exit→exit→select No.8 throttle curve setting→confirm → At this point we can see a row of number in bottom left corner inside the box (that is, two 0.0%) are black shadow → at this time press confirmation button, the black shadow, this is the cursor (we will introduce it with cursor as follows) will coruscate→ Hold down the (+) key until hear two beeps (At this time the position 0.0% has increased one curve point, which means that the position 0.0% have two curve points, of course, there is no need to have two curve points in one position, so the introduction of how to move curve point will be shown later) → Press confirmation button to let cursor stop blinking →Press the right key to move the curve point to +16.7% → Press confirmation button, the cursor blink → Hold down the (+) key until hear two beeps (At this time the position 0.0% has increased one curve point) → That means there are two points have been increased, then about the third curve point, put the cursor in +33.3% position with the same operation in accordance with the above can be, and there are seven curves of the original design point, a maximum of can be set to 10 curve points, that is, 3 points can be increased.

## (2) Move curve point operations are as follows

When you want to adjust the data of curve point, such as you have increased one curve point in the 0.0% position, if you want to make the increased point to move to +5.5% position, please select the 0.0% this curve point, that means in the throttle curve settings menu make the cursor in 0.0% position, → Press confirmation button to make the cursor blink → Press the right button to move the right of the data in the cursor blinking area to transfer to +5.5% → confirmation

Of course, not just in one place there are two curves of points should be adjusted then moving curve point, whatever you want to move the curve point can be adjusted in accordance with this method. Another point on the operation for reduction of curve point is to use(-)key stead of (+) key, press OK button, it is simple.

**Note:** Here is the explanation to the two curves of points in a position, when the two curves points in one position, the eyes can't see, but only when the cursor stops blinking, when you press the right or left button, actually, the numbel below the cursor haven't any changes, it means the broken line of the curve point also haven't any changes, that means there are two curve points in the position now.

The picture can show there are ten curve points.

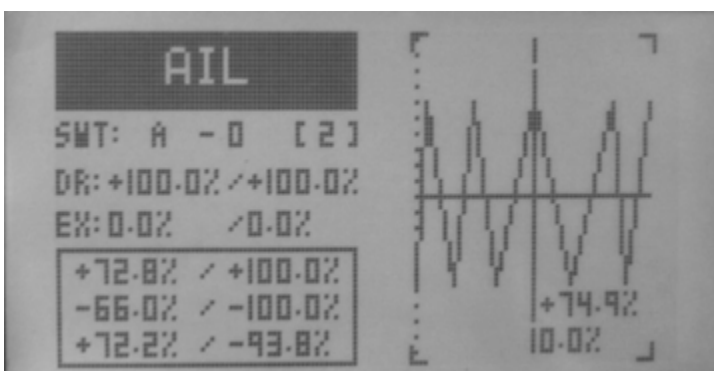

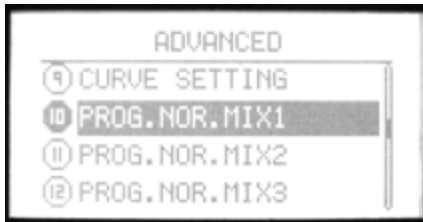
**(10)-(16). PROG. NOR. MIX1-7**

The mix program is to adjust the flying pose. There are 7 series programs with the same setting method. You can set one mix and one mix with another one mix.

**Setting Method**

Use up/down button to select **PROG. NOR. MIX**, OK button is to enter editing.

**Steps:**

1. Use direction buttons to select editing part. Set any two channels mix.
2. Use +/- button to active or inhibit "Mix".
3. Use +/- button to active or inhibit "Link" and "TRIM".
4. Use +/- button to active or inhibit "CTRL".
5. Use +/- button to set the control switch position.
6. Press EXIT after setting.

**(17)-(20). PROG. CUR. MIX1-4**

There are 4 curve mix program, the curve is made up by 2 to 10 point.

**Setting Method:**

Use up/down button to select **PROG. CUR. MIX**, OK button is to enter editing.

**Steps:**

1. Use direction buttons to select editing part. Set any two channels mix.
2. Use +/- button to active or inhibit "Mix".
3. Use +/- button to active or inhibit "Link" and "TRIM".
4. Use +/- button to active or inhibit "CTRL".
5. Use +/- button to set the control switch position.
6. Set the curve point.(Normal/Advanced). Please refer to page 27.
7. Press EXIT after setting.

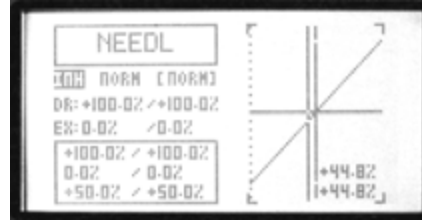
**(21). THROTTLE NEEDLE MIXING**

Throttle needle is a pre-programmed mix that automatically moves an in-flight mixture servo in response to the Throttle Stick inputs for perfect engine tuning at all throttle settings. This function is particularly popular with contest pilots who fly in a large variety of locations, needing regular engine tuning adjustments, and requiring perfect engine response at all times and in all maneuvers. Also popular to minimize flooding at idle of inverted engine installations or installations with a high tank position. Not need for fuel injection engine, which do this automatically.

**Setting Method**

Use up/down button to select **Throttle needle mixing**, OK button is to enter editing.

**Steps:**

1. Use +/- button to active or inhibit this function.
2. Use +/- button to select one curve. There are 3 curves, NORM, IDLE1, IDLE2, IDLE3.
3. Use direction button to select "D/R"  
Edit one or two parameter.  
+/- buttons can increase or decrease the value.  
Press the OK button is to back default.
4. Use direction button to select "EX"  
Edit one or two parameter.  
+/- buttons can increase or decrease the value.  
Press the OK button is to back default.  
EX can adjust aileron, throttle, rudder sensitivity when the sticks are around the middle.  
There are a lot of mixes when "D/R" and "EX" come together.
5. Curve setting method please refer to page 27.

**(22). Code matching**

Please refer to page 16.

## AIRPLANE

Press Menu and turn on the transmitter to enter SYS SETTING.  
Select MODEL SETTING, press OK button to select the model type.  
Restart the transmitter after setting.

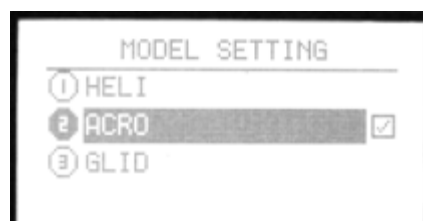
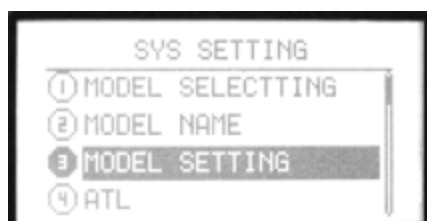

## Editing mode and function introduction

### 1. Opening Screen

Turn on the power switch, the LCD displays as follows.

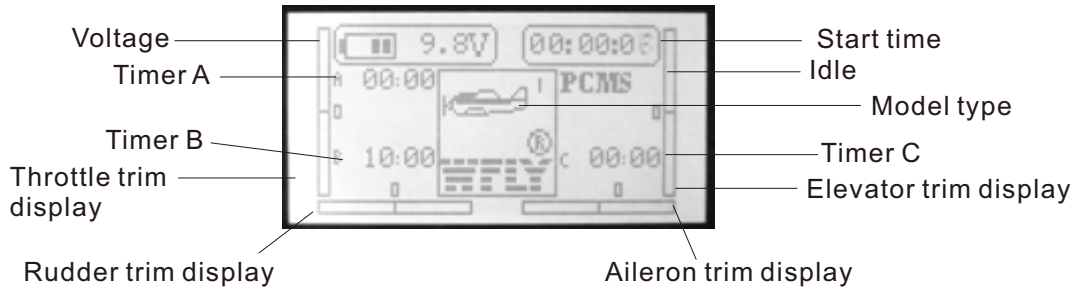

The opening screen displays the voltage, timer, model, aileron, throttle, elevator and rudder state.

Note: Press EXIT you can see the model name.

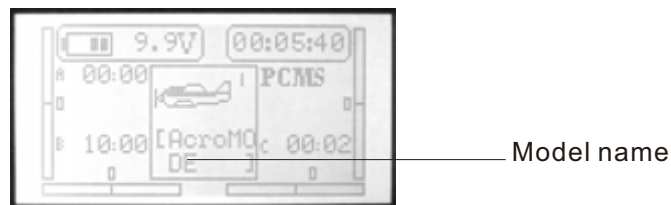

### 2. Menu Screen

There are “NORMAL SETTING”, “SYS SETTING”, “ADVANCED”.

#### A. NORMAL SETTING

Turn on the transmitter, press the menu button, the LCD displays as follows.

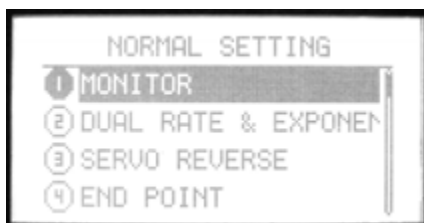

#### Setting method:

- Use direction button to select the editing part, use up/down buttons to select function item. Left/right direction button to turn page.
- Press OK button to enter submenu. The submenu function is in the next chapter.
- Press EXIT button to back previous menu and the data is set automatically.

- MONITOR
- DUAL RATE & EXPONENTIAL SETTING
- SERVO REVERSE
- END POINT
- SUB TRIM
- AUXILIARY CHANNELS SETTING
- THROTTLE CURVE SETTING
- TRIM STEP SETTING
- FLAPERON
- FLAP TRIM
- AIL-DIFF
- ELEV-FLAP
- THROTTLE CUT SETTING
- IDLE DOWN
- FAIL SAFE
- TIMER
- ADVANCED
- LANGUAGE

## B. SYS SETTING

Press Menu and turn on the power switch, the LCD displays as follows.

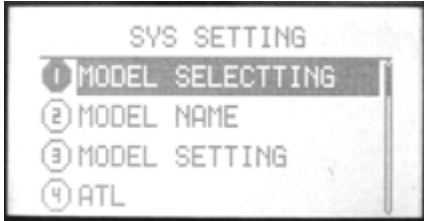

1. MODEL SELECTING
2. MODEL NAME
3. MODEL SETTING
4. ATL
5. AIL-2
6. MODULATION SETTING
7. STICK SETTING
8. ADJUSTMENT
9. REST SETTING
10. SEND DATA
11. RECEIVE DATA
12. SOUND
13. CONTRAST SETTING
14. ENGINEER MODEL
15. ABOUT
16. LANGUAGE

Setting method:

1. Use direction button to select the editing part, use up/down buttons to select function item. Left/right direction button to turn page.

2. Press OK button to enter submenu. The submenu function is in the next chapter.

3. Press EXIT button to back previous menu and the data is set automatically.

## C. ADVANCED

1. Enter "NORMAL SETTING", use right direction button to turn page, select "ADVANCED".

Press OK button to enter.

Setting method:

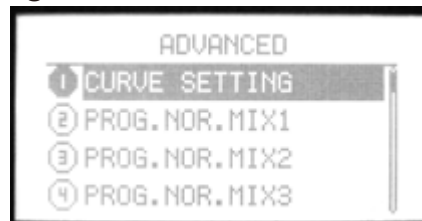

1. Use direction button to select the editing part, use up/down buttons to select function item. Left/right direction button to turn page.

2. Press OK button to enter submenu. The submenu function is in the next chapter.

3. Press EXIT button to back previous menu and the data is set automatically.

## SYS SETTING

### 1.MODEL SELECTTING

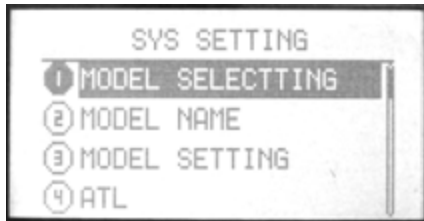

There are 85 airplane models. You can select any one to set.

#### Setting Method:

Press Menu and turn on the transmitter to enter "SYS SETTING"  
Use up/down button to select "**MODEL SELECTTING**", OK button is to enter editing.

#### Steps:

1. Use up/down direction button to select the model.
2. Press OK button to select.
3. Press EXIT after setting.

## 2. MODEL NAME

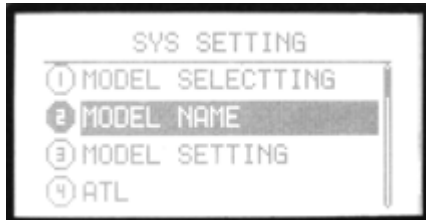

This function is to make new names by users.

### Setting Method:

Press Menu and turn on the transmitter to enter "SYS SETTING"  
Use up/down button to select "**MODEL NAME**", OK button is to enter editing.

### Steps:

1. You can edit the underlined letter.
2. Press OK button to choose the word you like.
3. Press EXIT after setting.

### 3. MODEL SETTING

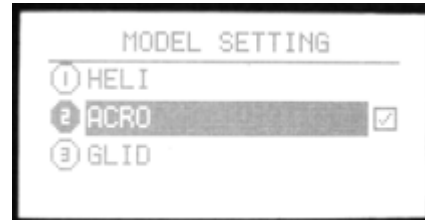
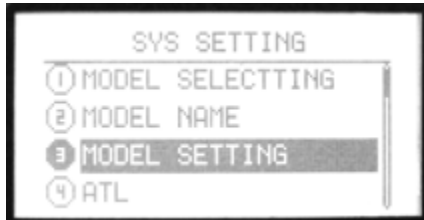

You can select the model type. There are three type: HELI, ACRO, GLID.

#### Setting Method:

Press Menu and turn on the transmitter to enter "SYS SETTING"  
Use up/down button to select "**MODEL SETTING**", OK button is to enter editing.

#### Steps:

1. Use up/down direction button to select the model type.
2. Press OK button to confirm.
3. Press EXIT after setting.

## 4. ATL

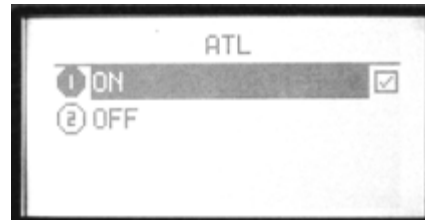

Adjustable travel limit (ATL) makes throttle trim effective only at low throttle, disabling the trim at high throttle. This prevents pushrod jamming due to idling trim changes. This function defaults to ON. If you are not using channel 3 for throttle, you may want trim operation the same as on all other channels. To do so, set ATL to OFF.

### Setting Method:

Press Menu and turn on the transmitter to enter "SYS SETTING"  
Use up/down button to select "**ATL**", OK button is to enter editing.

### Steps:

1. Use direction buttons to select the editing part.
2. Press +/- button to set ATL function.
3. Press EXIT after setting.

## 5. AIL-2

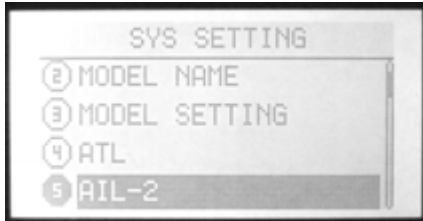

AIL-2 is another channel for aileron.

### Setting Method:

Press Menu and turn on the transmitter to enter "SYS SETTING"  
Use up/down button to select "AIL-2", OK button  
is to enter editing.

### Steps:

1. Use direction buttons to select.
2. Press OK button to confirm.
3. Press EXIT after setting.

## 6. MODULATION SETTING

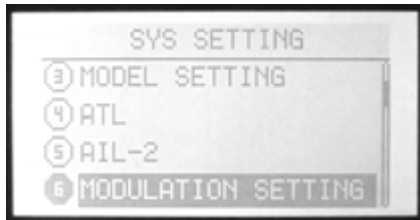

Because of the different receiver modulation PPM/PCMS1024/2.4G PCMS4096, the transmitter should be accordance with the receiver modulation.

### Setting Method:

Press Menu and turn on the transmitter to enter "SYS SETTING"  
Use up/down button to select "**Modulation setting**", OK button is to enter editing.

### Steps:

1. Use direction buttons to select the editing part.
2. Press OK button to confirm. Restart the transmitter and it works.

## 7.RF setting

Please refer to page 27.

## 8. STICK SETTING

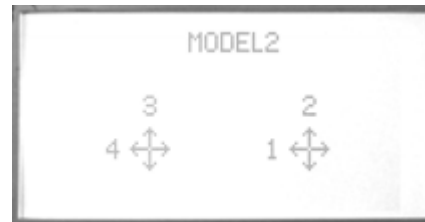
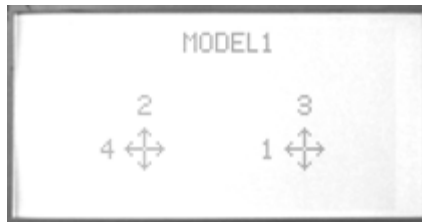
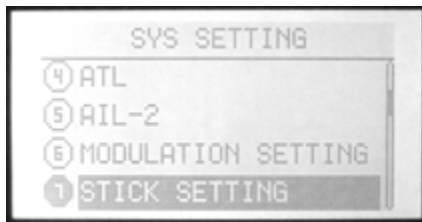

There are 4 kinds of model, you can use up/down direction button to select the model you preferred.

- 1-aileron
- 2-elevator
- 3-throttle
- 4-rudder

### Setting Method:

Press Menu and turn on the transmitter to enter "SYS SETTING"  
Use up/down button to select "**STICK SETTING**", OK button is to enter editing.

### Steps:

1. Use direction button to select the editing part.
2. Press up/down button to choose Stick mode.
3. Press EXIT after setting.

## 9.Adjustment

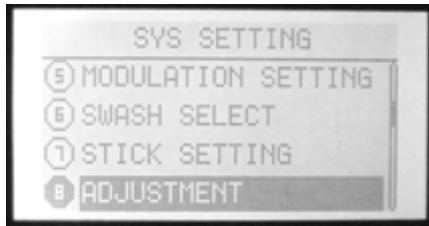

This function is to set the central, high and low point of four sticks when users changed the mode I or II by themselves.

### Setting Method:

Press Menu and turn on the transmitter to enter "SYS SETTING"  
Use up/down button to select "**ADJUSTMENT**", OK button is to enter editing.

### Steps:

1. Use direction button to select the editing part. Take the aileron adjustment for example.
2. Make the stick in the mid-point location. Press OK button to select any stick you want to adjust.
3. Select into the Figure 2, when the "center" highlights, press the "ok" button directly (the mid-point has been adjusted), then enter the high adjust.
4. The "high" highlights, take the stick gently in the right side (throttle /elevator in the top, aileron / rudder in the right),press "ok" button ( the max adjust is OK), enter the low adjustment.
- 5.The "low" highlights, take the stick gently in the left side (throttle /elevator in the bottom, aileron / rudder in the left),press "ok" button (the min adjust is OK).
6. Press OK or RESET to confirm the record or reset.
7. If the record is wrong, press OK will back to step 3.

## 10.RESET SETTING

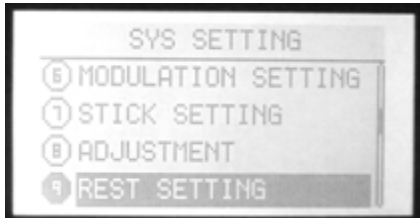

This function is to back default.

### Setting Method:

Press Menu and turn on the transmitter to enter "SYS SETTING"  
Use up/down button to select "**RESET SETTING**", OK button is to enter editing.

### Steps:

1. Use direction button to select the editing part.
2. Press +/- button to back default.
3. Press EXIT after setting.

## 11. SEND DATA

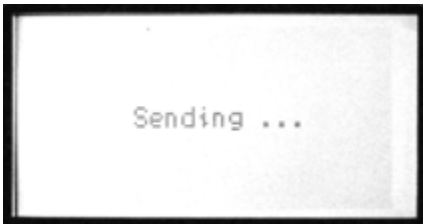
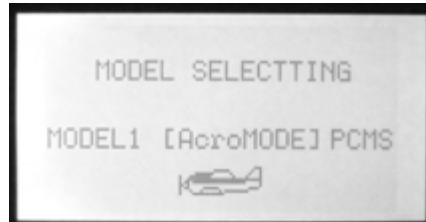
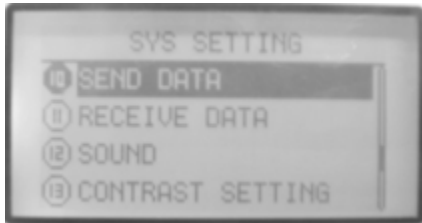

Two transmitters (WFT09S) can copy data by a trainer cable/data transfer cable. This function together with the next function “Receive data” can realize the data copy.

### Setting Method:

Press Menu and turn on the transmitter to enter “SYS SETTING”  
Use up/down button to select “**SEND DATA**”, OK button is to enter editing.

### Steps:

1. Select the model data you want to send out.
2. Press OK to send.

## 12.RECEIVE DATA



Two transmitters (WFT09S) can copy data by a trainer cable/data transfer cable. This function together with the previous function "Send data" can realize the data copy.

### Setting Method:

Press Menu and turn on the transmitter to enter "SYS SETTING"  
Use up/down button to select "**RECEIVE DATA**", OK button is to enter editing.

### Steps:

1. Press OK to receive data.
2. Restart the transmitter after receiving the data and it works.

### 13.Sound

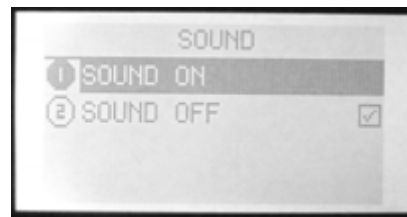
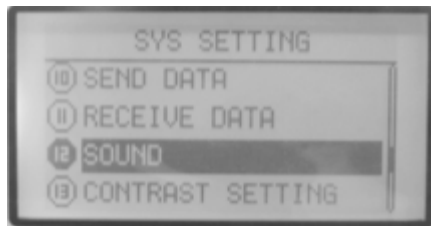

This function is to select the sound ON and OFF.

#### Setting Method:

Press Menu and turn on the transmitter to enter "SYS SETTING"  
Use up/down button to select "SOUND", OK button is to enter editing.

#### Steps:

1. Use +/- button to select ON and OFF.
2. Press OK button to confirm.
3. Press EXIT after setting.

## 14.CONTRAST SETTING

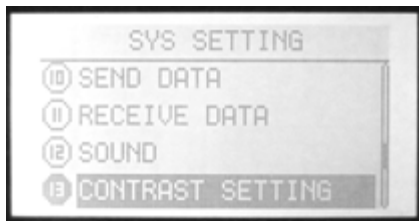

This function is to adjust the LCD brightness by increasing or decreasing the contrast value.

### Setting Method:

Press Menu and turn on the transmitter to enter "SYS SETTING"  
Use up/down button to select "**RECEIVE DATA**", OK button is to enter editing.

### Steps:

1. Use +/- button to increase or decrease the value.
2. Press OK button for a while is to back default.
3. Press EXIT after setting.

## 16.LANGUAGE

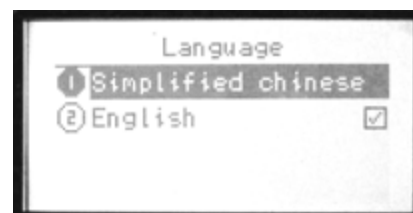
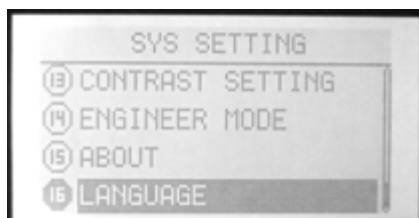

This function is to select the language. The selection is as shown in the picture, if only English or Chinese menu, the function is not exist.

## NORMAL SETTING(AIRPLANE)

### 1. MONITOR

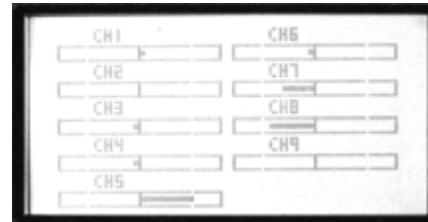
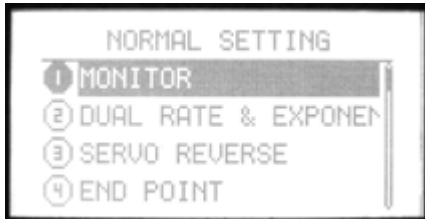

Monitor shows the servos' movement situation.

In PCMS, this function is to describe the 9 channels output.

In PPM, this function is to describe the first 8 channels output.

#### Setting Method:

Press menu button, enter system setting, the first function is the monitor.

## 2. DUAL RATE & EXPONENTIAL SETTING

### (1). AIL

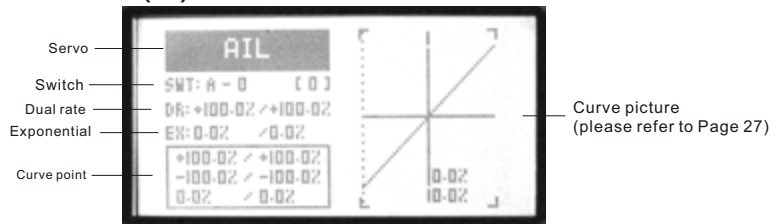
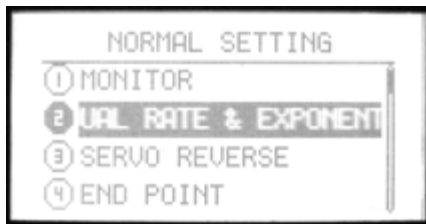

### (2). ELE

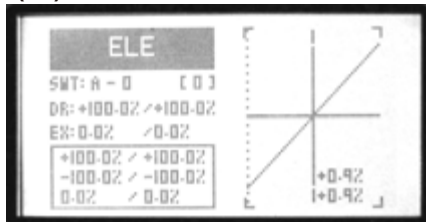

### (3). RUD

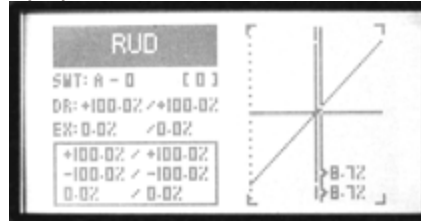

Dual rate is to adjust aileron, elevator and rudder travel range. The range is between 0%-120%.

Exponential setting is to adjust aileron, elevator and rudder sensitivity when the sticks are around the middle. The range is between -100% to +100%.

### Setting Method:

#### 1. Select channel

Aileron, elevator and rudder are selectable. Press +/- buttons to select channel, OK button to finish setting.

#### 2. Set the switch and its position(0,1,2)

Press direction button to select "SWT", edit it. +/- buttons can select function switch(A-F).

After selecting the function switch, press right direction button to enter the switch position setting, use +/- buttons to set.

#### 3. Set dual rate

Press direction button to select "D/R", edit it. Edit one or two parameter.

+/- buttons can increase or decrease the value.

Press the OK button is to back default.

#### 4. Set exponential

Press direction button to select "EX". Exponential can adjust aileron, throttle and rudder sensitivity as the stick at the middle.

#### 5. Set curve point (normal/advanced)

The box under "EX" shows the curve points.

Select "Curve setting" in More setting function list.

Please refer to Page 27 for detail curve setting.

#### 6. Press EXIT after all the values are finished setting.

### 3. SERVO REVERSE

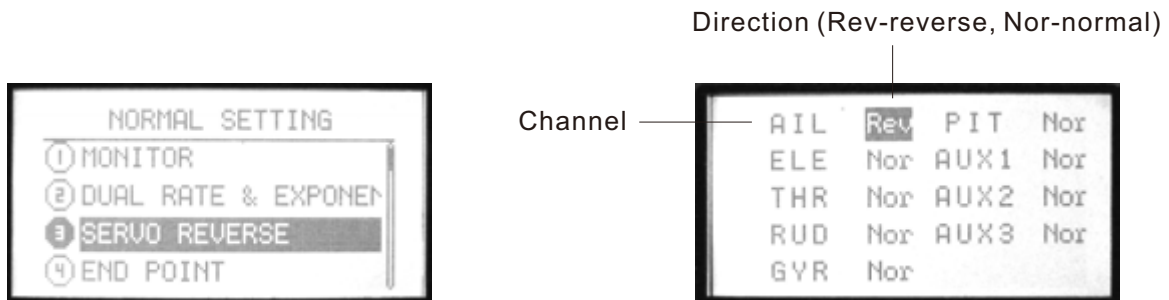

This function is to change the direction of the servos movement.

#### Setting Method:

Use up/down button to select **SERVO REVERSE**, OK button is to enter editing.

#### Steps:

1. Use direction buttons to select editing part.
2. Use +/- button or OK button to switch the servo movement direction.
3. Press EXIT after setting.

## 4. END POINT



It is to adjust the end of individual servo's travel. The range is from 0% to 120%.

### Setting Method:

Use up or down button to select **END POINT**, OK button is to enter editing.

### Steps:

1. Use direction buttons to select editing part.
2. Use +/- button or OK button to set the travel value. Press OK for a while backs to default.
3. Press EXIT after setting.

## 5. SUB TRIM



Sub trim makes small changes or corrections to the neutral position of each servo. Range is -120 to +120, default setting is 0.

We recommend that you center the digital trims before making Sub trim changes, and that you try to keep all of the Sub trim values as small as possible. Otherwise, when the Sub trims are large values, the servo's range of travel is restricted on one side.

### Setting Method:

Use up or down button to select **SUB TRIM**, OK button is to enter editing.

### Steps:

1. Use direction buttons to select editing part.
2. Use +/- button or OK button to set the trim value. Press OK for a while backs to default.
3. Press EXIT after setting.

## 6. AUXILIARY CHANNELS SETTING

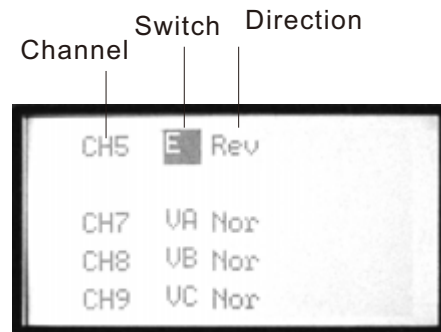
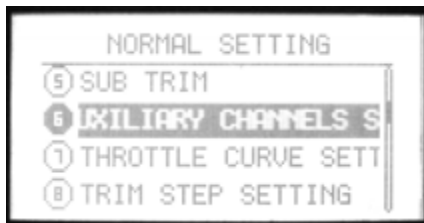

This function is for channel 5 to channel 9 function setting.

### Setting Method:

Use up or down button to select **AUXILIARY CHANNELS SETTING**, OK button is to enter editing.

### Steps:

1. Use direction buttons to select editing part.
2. Use +/- button to set the switches or knobs. The switches can be set from A to F, the knobs can be set as VA, VB, VC, VL, VR or none(-).
3. Use left or right direction button to set normal or reverse direction of every channel.
4. Press EXIT after setting.

## 7. THROTTLE CURVE SETTING

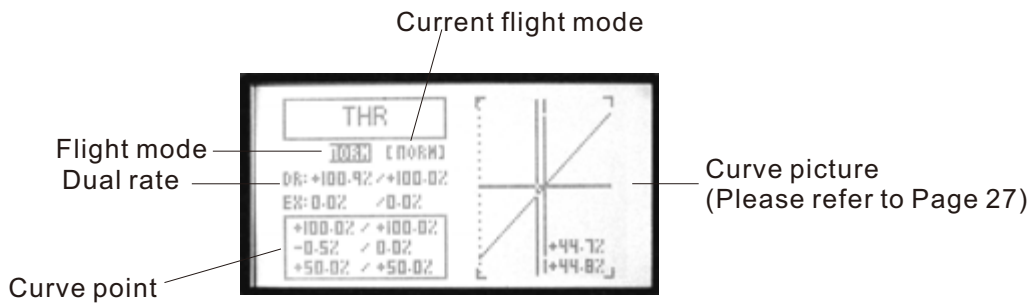
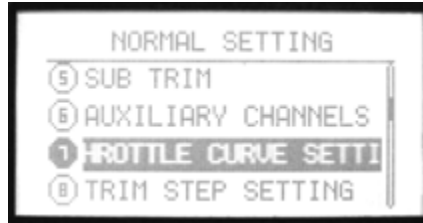

Throttle curve, together with the throttle stick, can be adjusted properly to maximize engine performance at a particular pitch setting.

There are two kinds of curve setting, normal (7 points curve), advanced (2-10 points curve), the range is between 0%-120%. The transmitter can set the following curves: NORM, IDLE1, IDLE2, IDLE3.

Normal curve is based on hovering, to maximize engine performance at a particular pitch setting.

Idle curve is for engine proper work in a 3D flight, with a good match between throttle and pitch.

**Setting Method:**

Use up/down button to select **THROTTLE CURVE SETTING**, OK button is to enter editing.

**Steps:**

1. Flight(NORM IDLE1 IDLE2 IDLE3)  
Use direction buttons to select editing part. Use +/- button to select one curve.
2. Set Dual rate  
Use direction button to select "D/R" and edit (one or two values can be set separately or together). Press +/- button for seconds can increase or delete the value. Press OK button for seconds is to back default(60%).
3. Curve point setting(Normal/Advanced)  
The below pane shows the points curve.  
Select "Curve setting" in "SYS setting", choose the curve.  
For detail curve setting method please refer to Page 27.
4. Press EXIT after setting.

## 8. TRIM STEP SETTING

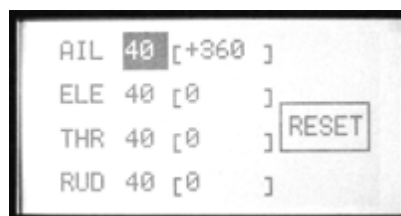

This function is to change the rate at which the trim moves when the TRIM LEVER is activated. The range is from 1 to 250. Generally larger trim steps are for models with larger control throws or for first flights to ensure sufficient trim to properly correct the model. Smaller trim steps are later used to allow very fine adjustments in flight.

### Setting Method:

Use up/down button to select **TRIM STEP SETTING**, OK button is to enter editing.

### Steps:

1. Use direction buttons to select editing part.
2. Use +/- button to adjust the size of the step. Repeat as desired for other channels. If you select RESET, the current channel trim value change to 0.
3. Press EXIT after setting.

## 9. FLAPERON

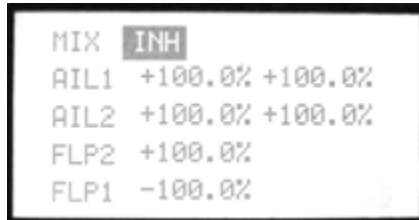
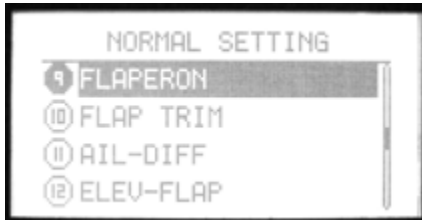

FLAPERON mixing function uses on servo on each of the two ailerons, and uses them for both aileron and flap function.

### Setting Method:

Use up/down button to select **FLAPERON**, OK button is to enter editing.

### Steps:

1. Use direction buttons to select editing part.
2. Use +/- button to set value. Press OK button for seconds can back default.
3. Press EXIT after setting.

## 10. FLAP TRIM

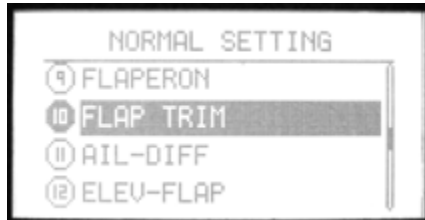

FLAP TRIM assigns the primary flaperon control to allow trimming in flight of the flap action of flaperons.

### Setting Method:

Use up/down button to select **FLAP TRIM**, OK button is to enter editing.

### Steps:

1. Use direction buttons to select editing part.
2. Use +/- button to set value. Press OK button for seconds can back default.
3. Press EXIT after setting.

## 11. AIL-DIFF

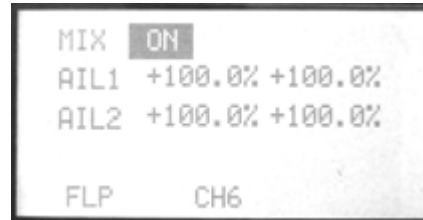

Aileron differential(AIL-DIFF) is primarily used on 3-servo wings, with one servo operating inboard flap(s) on Ch6, and AIL-DIFF controlling proper aileron operation of 2 aileron servos, plugged into Ch1 and Ch7.

### Setting Method:

Use up/down button to select **AIL-DIFF**, OK button is to enter editing.

### Steps:

1. Use direction buttons to select editing part.
2. Use +/- button to set value. Press OK button for seconds can back default.
3. Press EXIT after setting.

## 12. ELEV-FLAP

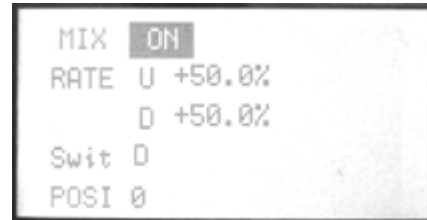

ELEV-FLAP mixing is the first pre-programmed mix we'll cover. This mix makes the flaps drop or rise whenever the elevator stick is moved. It is most commonly used to make tighter pylon turns or squarer corners in maneuvers. In most cases, the flaps droop (are lowered) when up elevator is commanded.

### Setting Method:

Use up/down button to select **ELEV-FLAP**, OK button is to enter editing.

### Steps:

1. Use direction buttons to select editing part.
2. Use +/- button to set value. Press OK button for seconds can back default.
3. Press EXIT after setting.

### 13. THROTTLE CUT SETTING

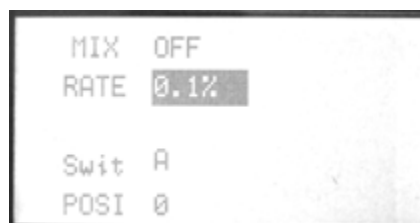
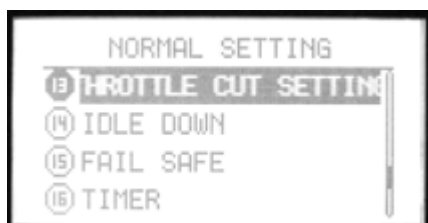

This function is to shut off the engine at the end of a flight. The engine can be stopped with one touch of any switch, eliminating the need to move the trim to kill the engine and then readjust prior to each flight. The helicopter THR CUT includes an ON/OFF throttle position (normally a little above idle). You must move the THROTTLE STICK back below the set point before the THR-CUT function can be reset, to avoid sudden engine acceleration.

#### Setting Method:

Use up/down button to select **THROTTLE CUT SETTING**, OK button is to enter editing.

#### Steps:

1. Use direction buttons to select editing part.
2. Use +/- button to turn on/off throttle cut function.
3. Use +/- button to set the throttle rate and trim (range is between +45% to -45%).
4. Use +/- button to set the position.
5. Press EXIT after setting.

## 14. IDLE DOWN

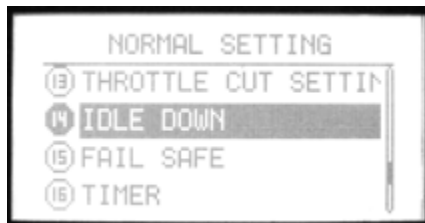

This function is to lower the engine idle for: sitting on the runway prior to take off, stalls and spins, and landings. The normal idle setting is a little higher for easier starts and safe flights with less risk of dead sticks.

The idle down function is not normally used when starting the engine, and its accidental operation may keep your engine from starting.

### Setting Method:

Use up/down button to select **IDLE DOWN**, OK button is to enter editing.

### Steps:

1. Use direction buttons to select editing part.
2. Use +/- button to set value. Press OK button for seconds can back default.
3. Press EXIT after setting.

## 15. FAIL SAFE

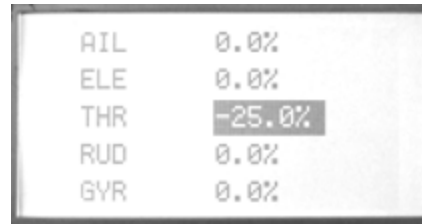
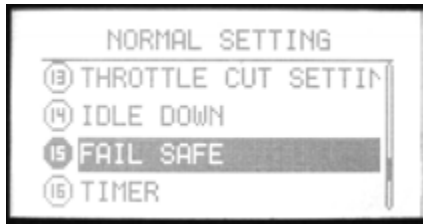

This function is to set responses in case of loss of signal or low RX battery.

### Setting Method:

Use up/down button to select **FAIL SAFE**, OK button is to enter editing.

### Steps:

1. Use direction buttons to select editing part.
2. Use +/- button to select "hold" or "0.0%"
3. Press OK button to confirm the current parameter.
4. Press EXIT after setting.

## 16. THROTTLE HOLDING SETTING

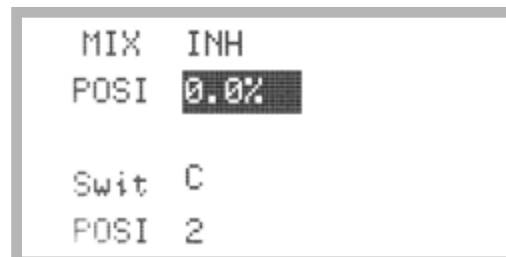
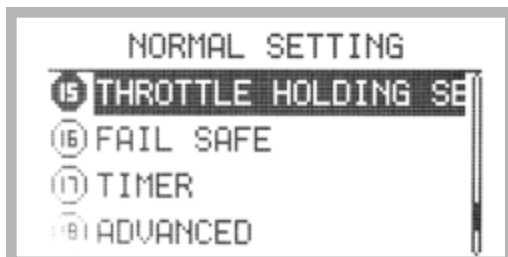

### Description

throttle hold setting allows the user fix the throttle at the low value when landing. Throttle hold setting value can be adjusted between +/-100%.

### Setting

Enter Normal setting menu, use up or down button to select throttle hold setting. Press OK button to enter value setting.

### Value setting method

- 1, use direction button to highlight the item and enter value edit mode
- 2, use +/- to set the MIX value as "ON/OFF" or "Inhibit".
- 3, use +/- to set the value under "Position" option. Press and hold OK button to reset to default value.
- 4, under switch option, Use +/- to choose the switch to active this function
- 5, use +/- to set the on/off position of the switch. press and hold Ok button can back to default setting.
- 6, press exit button to quit after

## 17. TIMER

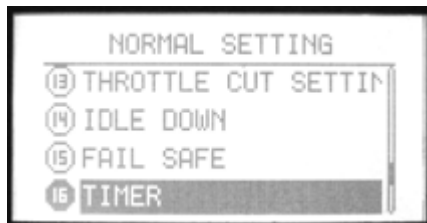

The flight time of every helicopter is different according to the different tank of fuel, engine, ESC, etc. Timer function can alarm you to land before the fuel lacks.

The transmitter can set 3 timers (A, B, C). The longest time can be set as MM99SS59. The countdown timer can alarm user before 10 minutes. The alarm will become 2S/1S from 1S/1S in the last 10 seconds. When the countdown timer is 0, the time will add up.

The timer can be seen in the opening screen. Any switch can be set to control the begin and stop of the time.

### Setting Method:

Use up/down button to select **TIMER**, OK button is to enter editing.

### Steps:

1. Use direction buttons to select editing part.
2. Set timer. WFT09S can set 3 timers (A, B, C).
3. Use +/- button to set MM..SS... Press OK button for seconds can back to default.
4. Use +/- button to set model.
5. Use +/- button to set control(CTRL).
6. Use +/- button to set the position which can active this function.
7. Press EXIT after setting.

## 19. Language

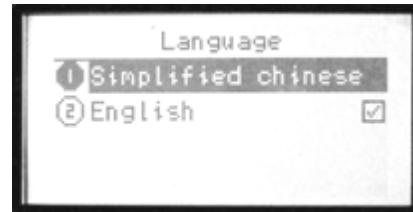

This function is to select the language, Simplified Chinese and English can be selected.

## 18. ADVANCED



To realize an idea fly, there are 20 advanced function in ADVANCED.

### Setting Method:

Use up/down button to select ADVANCED, OK button is to enter editing. +/- button can turn page.  
About each advanced functions please read the following pages.

## ADVANCED function introduction

### (1). CURVE SETTING

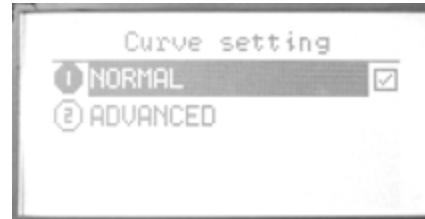
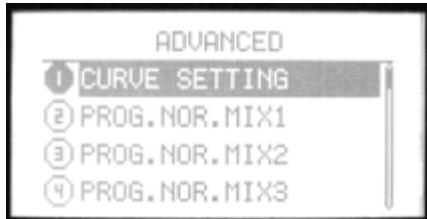

There are 2 kinds of setting, Normal and Advanced.  
Please refer to page 27.

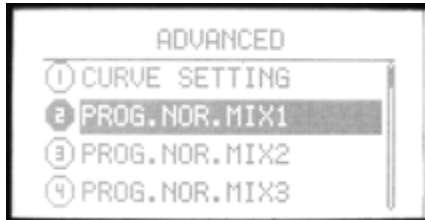
**(2)-(8). PROG. NOR. MIX1-7**

The mix program is to adjust the flying pose. There are 7 series programs with the same setting method. You can set one mix and one mix with another one mix.

**Setting Method**

Use up/down button to select **PROG. NOR. MIX**, OK button is to enter editing.

**Steps:**

1. Use direction buttons to select editing part. Set any two channels mix.
2. Use +/- button to active or inhibit "Mix".
3. Use +/- button to active or inhibit "Link" and "TRIM".
4. Use +/- button to active or inhibit "CTRL".
5. Use +/- button to set the control switch position.
6. Press EXIT after setting.

**(9)-(12). PROG. CUR. MIX1-4**

There are 4 curve mix program, the curve is made up by 2 to 10 point.

**Setting Method:**

Use up/down button to select **PROG. CUR. MIX**, OK button is to enter editing.

**Steps:**

1. Use direction buttons to select editing part. Set any two channels mix.
2. Use +/- button to active or inhibit "Mix".
3. Use +/- button to active or inhibit "Link" and "TRIM".
4. Use +/- button to active or inhibit "CTRL".
5. Use +/- button to set the control switch position.
6. Set the curve point.(Normal/Advanced). Please refer to page 27.
7. Press EXIT after setting.

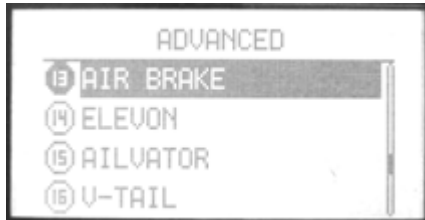
**(13). AIR BRAKE**

AIR BRAKE simultaneously moves the flaps, twin ailerons and elevators, and is usually used to make steep descents or to limit increases in airspeed in dives.

**Setting Method:**

Use up/down button to select **AIR BRAKE**, OK button is to enter editing.

**Steps:**

1. Use direction buttons to select editing part.
2. Use +/- button to active or inhibit "Mix".
3. Use +/- button to set Swit, POSI. Press OK button for seconds can back default.
4. Use +/- button to set CTRL (MAN/ THR).
5. Use +/- button to set delay value. Press OK button for seconds can back default.
6. Press EXIT after setting.

## (14). ELEVON

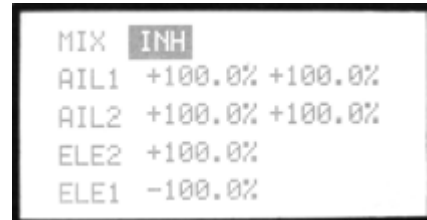
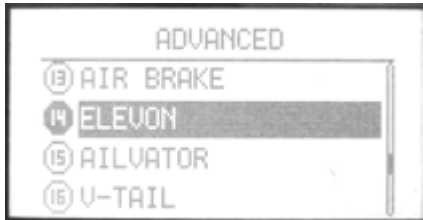

This function used with delta wings, flying wings, and other tailless aircraft that combine aileron and elevator functions, using two servos, one on each elevon. The aileron/elevator responses of each servo can be adjusted independently.

### Setting Method:

Use up/down button to select **ELEVON**, OK button is to enter editing.

### Steps:

1. Use direction buttons to select editing part.
2. Use +/- button to set value. Press OK button for seconds can back default.
3. Press EXIT after setting.

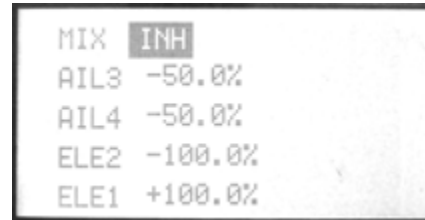
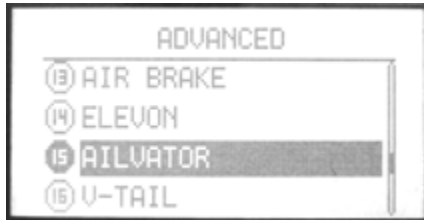
**(15). AILVATOR**

AILEVATOR mixing function uses one servo on each of the two elevators, and combines the elevator function with the aileron function(unless aileron travel is set to 0).

**Setting Method:**

Use up/down button to select **AILVATOR**, OK button is to enter editing.

**Steps:**

1. Use direction buttons to select editing part.
2. Use +/- button to set value. Press OK button for seconds can back default.
3. Press EXIT after setting.

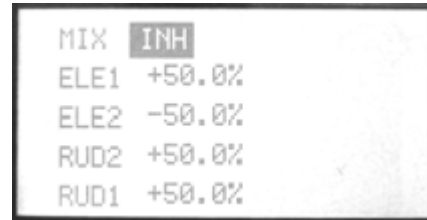
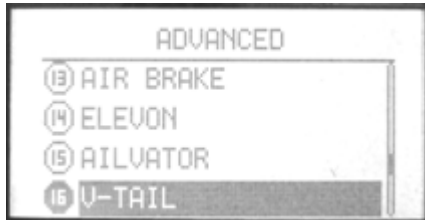
**(16). V-TAIL**

V-TAIL mixing is used with v-tail aircraft so that both elevator and rudder functions are combined for the two tail surfaces. Both elevator and rudder travel can be adjusted independently on each surface.

**Setting Method:**

Use up/down button to select **V-TAIL**, OK button is to enter editing.

**Steps:**

1. Use direction buttons to select editing part.
2. Use +/- button to set value. Press OK button for seconds can back default.
3. Press EXIT after setting.

## (17). SNAP-ROLL

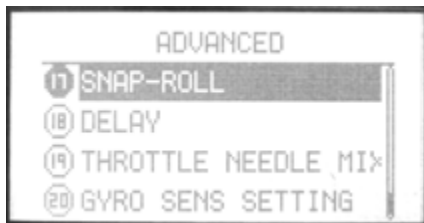

This function allows you to execute snap rolls by flipping a switch, providing the same input every time. It also removes the need to change dual rates on the 3 channels prior to performing a snap, as snap-roll always takes the servos to the same position, regardless of dual rates, inputs held during the snap, etc.

### Setting Method:

Use up/down button to select **SNAP-ROLL**, OK button is to enter editing.

### Steps:

1. Use direction buttons to select editing part.
2. Use +/- button to set value. Press OK button for seconds can back default.
3. Press EXIT after setting.

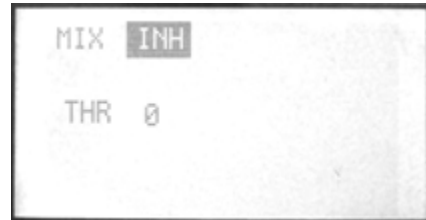
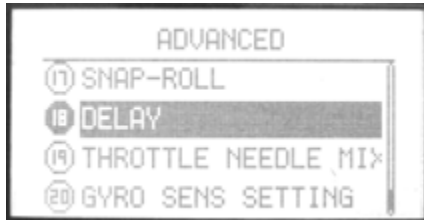
**(18). DELAY**

DELAY function is used to slow the response of the throttle servo to simulate the slow response of a turbine engine.

**Setting Method:**

Use up/down button to select **DELAY**, OK button is to enter editing.

**Steps:**

1. Use direction buttons to select editing part.
2. Use +/- button to active or inhibit **T** his function. Press OK button for seconds can back default.
3. Press EXIT after setting.

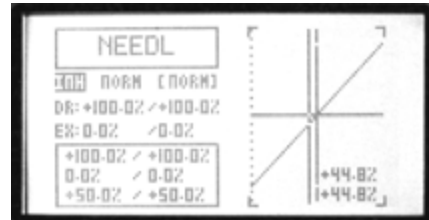
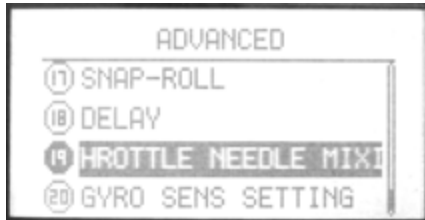
**(19). THROTTLE NEEDLE MIXING**

Throttle needle is a pre-programmed mix that automatically moves an in-flight mixture servo in response to the Throttle Stick inputs for perfect engine tuning at all throttle settings. This function is particularly popular with contest pilots who fly in a large variety of locations, needing regular engine tuning adjustments, and requiring perfect engine response at all times and in all maneuvers. Also popular to minimize flooding at idle of inverted engine installations or installations with a high tank position. Not need for fuel injection engine, which do this automatically.

**Setting Method**

Use up/down button to select **Throttle needle mixing**, OK button is to enter editing.

**Steps:**

1. Use +/- button to active or inhibit this function.
2. Use +/- button to select one curve. There're 3 curves, NORM, IDLE1, IDLE3.
3. Use direction button to select "D/R"  
 Edit one or two parameter.  
 +/- buttons can increase or decrease the value.  
 Press the OK button is to back default.
4. Use direction button to select "EX"  
 Edit one or two parameter.  
 +/- buttons can increase or decrease the value.  
 Press the OK button is to back default.  
 EX can adjust aileron, throttle, rudder sensitivity when the sticks are around the middle.  
 There are a lot of mixes when "D/R" and "EX" come together.
5. Curve setting method please refer to page 27.

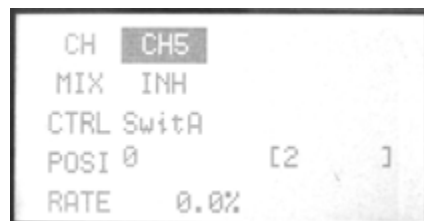
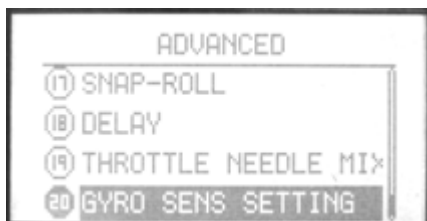
**(20). GYRO SENS SETTING**

User can adjust the gyro sensitivity by transmitter, AVCS gyro (GY) and normal gyro (STD). Gyro sensitivity switch plug should plug in the fifth channel of receiver. The auxiliary channel CH 5 won't have any function now. User can set sensitivity switch from switch A to F, and also fly model (NORM, IDLE1,2,3).

**Setting Method:**

Use up/down button to select **GYRO sens setting**, OK button is to enter editing.

**Steps:**

1. Use direction buttons to select editing part.
2. Use +/- button to set fly model at "MODE".
3. Use +/- button to active or inhibit "Mix". Press OK button for seconds can back default.
4. Use +/- button to set control switch at "CTRL".
5. Use +/- button to set the switch position when the function is active.
6. Use +/- button to set the "Rate". Press OK button for seconds can back default.
7. Press EXIT after setting.

**(21). Code matching**

Please refer to page 16.

## GLIDER

Press Menu and turn on the transmitter to enter SYS SETTING.  
Select MODEL SETTING, press OK button to select the model type.  
Restart the transmitter after setting.

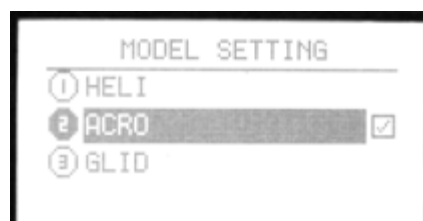
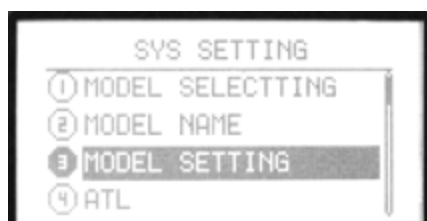

## Editing mode and function introduction

### 1. Opening Screen

Turn on the power switch, the LCD displays as follows.

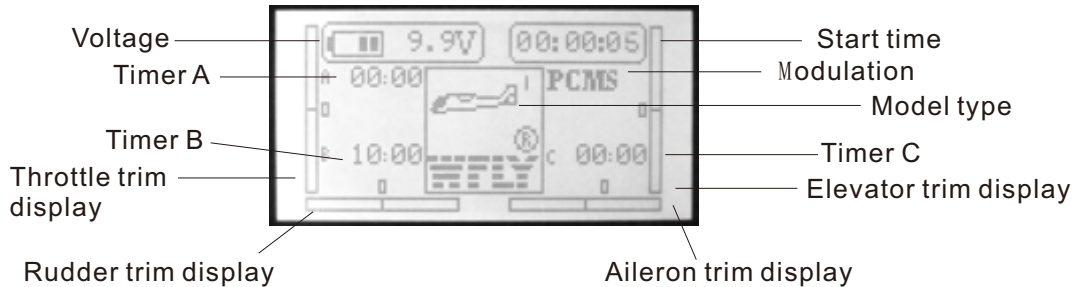

The opening screen displays the voltage, timer, model, aileron, throttle, elevator and rudder state.

Note: Press EXIT you can see the model name.

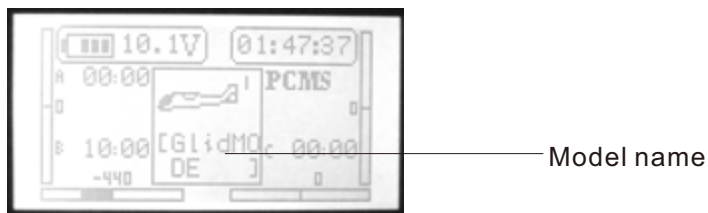

### 2. Menu Screen

There are “NORMAL SETTING”, “SYS SETTING”, “ADVANCED”.

#### A. NORMAL SETTING

Turn on the transmitter, press the menu button, the LCD displays as follows.

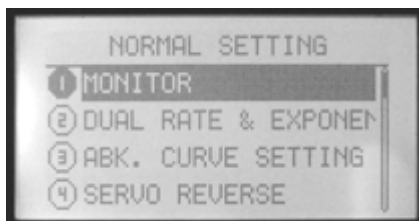

#### Setting method:

1. Use direction button to select the editing part, use up/down buttons to select function item. Left/right direction button to turn page.
2. Press OK button to enter submenu. The submenu function is in the next chapter.
3. Press EXIT button to back previous menu and the data is set automatically.

1. MONITOR
2. DUAL RATE & EXPONENTIAL SETTING
3. ABK. CURVE SETTING
4. SERVO REVERSE
5. END POINT
6. SUB TRIM
7. AUXILIARY CHANNELS SETTING
8. TRIM STEP SETTING
9. FLAPERON
10. FLAP TRIM
11. AIL-DIFF
12. ELEV-FLAP
13. FAIL SAFE
14. TIMER
15. ADVANCED
16. LANGUAGE

## B. SYS SETTING

Press Menu and turn on the power switch, the LCD displays as follows.

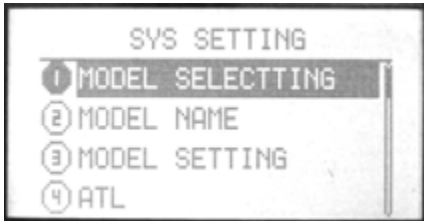

1. MODEL SELECTING
2. MODEL NAME
3. MODEL SETTING
4. ATL
5. AIL-2
6. MODULATION SETTING
7. STICK SETTING
8. ADJUSTMENT
9. REST SETTING
10. SEND DATA
11. RECEIVE DATA
12. SOUND
13. CONTRAST SETTING
14. ENGINEER MODE
15. ABOUT
16. LANGUAGE

Setting method:

1. Use direction button to select the editing part, use up/down buttons to select function item. Left/right direction button to turn page.

2. Press OK button to enter submenu. The submenu function is in the next chapter.

3. Press EXIT button to back previous menu and the data is set automatically.

## C. ADVANCED

1. Enter "NORMAL SETTING", use right direction button to turn page, select "ADVANCED".

Press OK button to enter.

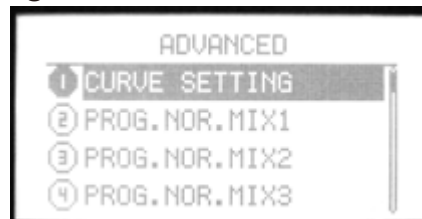

Setting method:

1. Use direction button to select the editing part, use up/down buttons to select function item. Left/right direction button to turn page.

2. Press OK button to enter submenu. The submenu function is in the next chapter.

3. Press EXIT button to back previous menu and the data is set automatically.

## SYS SETTING

### 1.MODEL SELECTTING

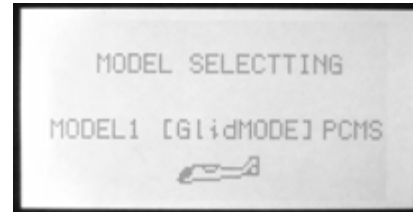
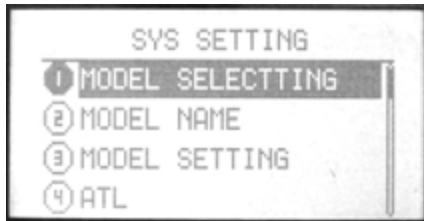

There are 85 glider models. You can select any one to set.

#### Setting Method:

Press Menu and turn on the transmitter to enter "SYS SETTING"  
Use up/down button to select "**MODEL SELECTTING**", OK button is to enter editing.

#### Steps:

1. Use up/down direction button to select the model.
2. Press OK button to select.
3. Press EXIT after setting.

## 2. MODEL NAME

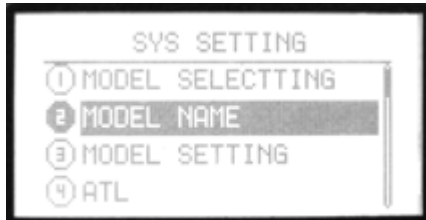

This function is to make new names by users.

### Setting Method:

Press Menu and turn on the transmitter to enter "SYS SETTING"  
Use up/down button to select "**MODEL NAME**", OK button is to enter editing.

### Steps:

1. You can edit the underlined letter.
2. Press OK button to choose the word you like.
3. Press EXIT after setting.

### 3. MODEL SETTING

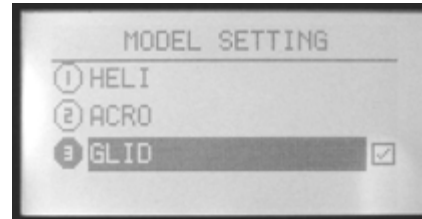
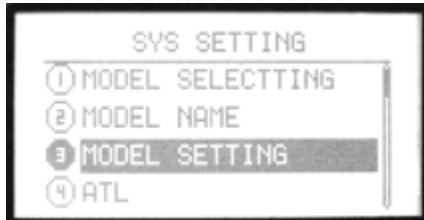

You can select the model type. There are three type: HELI, ACRO, GLID.

#### Setting Method:

Press Menu and turn on the transmitter to enter “SYS SETTING”  
Use up/down button to select “**MODEL SETTING**”, OK button is to enter editing.

#### Steps:

1. Use up/down direction button to select the model type.
2. Press OK button to confirm.
3. Press EXIT after setting.

## 4. ATL

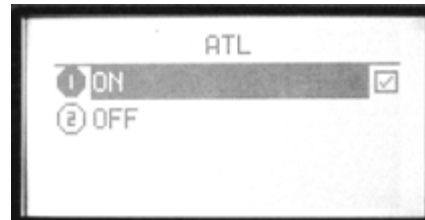

Adjustable travel limit (ATL) makes throttle trim effective only at low throttle, disabling the trim at high throttle. This prevents pushrod jamming due to idling trim changes. This function defaults to ON. If you are not using channel 3 for throttle, you may want trim operation the same as on all other channels. To do so, set ATL to OFF.

### Setting Method:

Press Menu and turn on the transmitter to enter "SYS SETTING"  
Use up/down button to select "**ATL**", OK button is to enter editing.

### Steps:

1. Use direction buttons to select the editing part.
2. Press +/- button to set ATL function.
3. Press EXIT after setting.

## 5. AIL-2

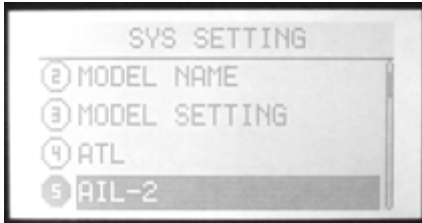

AIL-2 is another channel for aileron.

### Setting Method:

Press Menu and turn on the transmitter to enter "SYS SETTING"  
Use up/down button to select "AIL-2", OK button  
is to enter editing.

### Steps:

1. Use direction buttons to select.
2. Press OK button to confirm.
3. Press EXIT after setting.

## 6. MODULATION SETTING

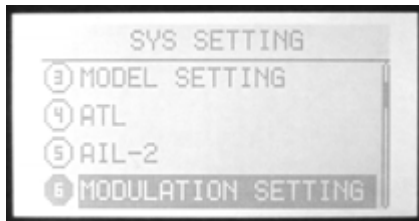

Because of the different receiver modulation PPM/PCMS1024, /2. 4G PCMS4096 the transmitter should be accordance with the receiver modulation.

### Setting Method:

Press Menu and turn on the transmitter to enter "SYS SETTING"  
Use up/down button to select "**Modulation setting**", OK button is to enter editing.

### Steps:

1. Use direction buttons to select the editing part.
2. Press OK button to confirm. Restart the transmitter and it works.

## 7.RF setting

Please refer to page 27.

## 8. STICK SETTING

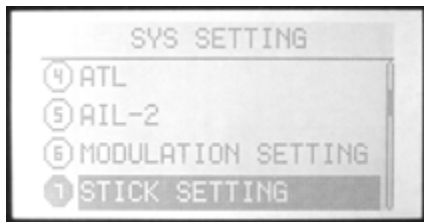

There are 4 kinds of model, you can use up/down direction button to select the model you preferred.

- 1-aileron
- 2-elevator
- 3-throttle
- 4-rudder

### Setting Method:

Press Menu and turn on the transmitter to enter "SYS SETTING"  
Use up/down button to select "**STICK SETTING**", OK button is to enter editing.

### Steps:

1. Use direction button to select the editing part.
2. Press up/down button to choose Stick mode.
3. Press EXIT after setting.

## 9.Adjustment

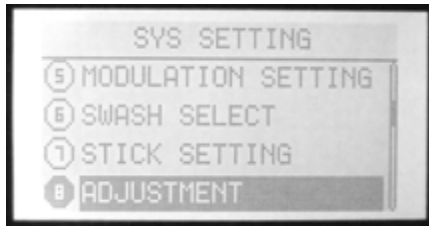

This function is to set the central, high and low point of four sticks when users changed the mode I or II by themselves.

### Setting Method:

Press Menu and turn on the transmitter to enter "SYS SETTING"  
Use up/down button to select "**ADJUSTMENT**", OK button is to enter editing.

### Steps:

1. Use direction button to select the editing part. Take the aileron adjustment for example.
2. Make the stick in the mid-point location. Press OK button to select any stick you want to adjust.
3. Select into the Figure 2, when the "center" highlights, press the "ok" button directly (the mid-point has been adjusted), then enter the high adjust.
4. The "high" highlights, take the stick gently in the right side (throttle /elevator in the top, aileron / rudder in the right),press "ok" button ( the max adjust is OK), enter the low adjustment.
- 5.The "low" highlights, take the stick gently in the left side (throttle /elevator in the bottom, aileron / rudder in the left),press "ok" button (the min adjust is OK).
6. Press OK or RESET to confirm the record or reset.
7. If the record is wrong, press OK will back to step 3.

## 10.RESET SETTING



This function is to back default.

### Setting Method:

Press Menu and turn on the transmitter to enter "SYS SETTING"  
Use up/down button to select "**RESET SETTING**", OK button is to enter editing.

### Steps:

1. Use direction button to select the editing part.
2. Press +/- button to back default.
3. Press EXIT after setting.

## 11. SEND DATA

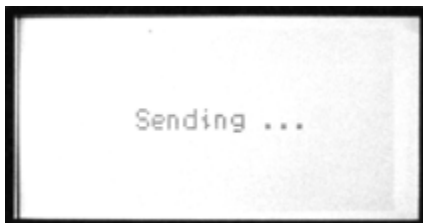
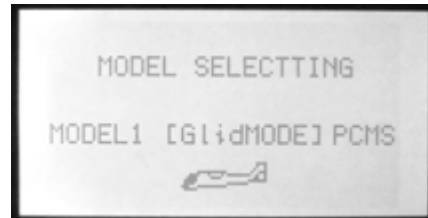
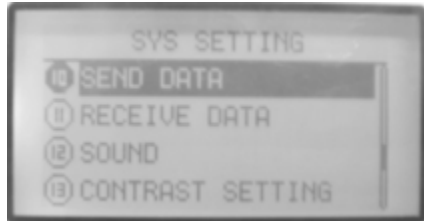

Two transmitters (WFT09S) can copy data by a trainer cable/data transfer cable. This function together with the next function “Receive data” can realize the data copy.

### Setting Method:

Press Menu and turn on the transmitter to enter “SYS SETTING”  
Use up/down button to select “**SEND DATA**”, OK button is to enter editing.

### Steps:

1. Select the model data you want to send out.
2. Press OK to send.

## 12.RECEIVE DATA



Two transmitters (WFT09S) can copy data by a trainer cable/data transfer cable. This function together with the previous function "Send data" can realize the data copy.

### Setting Method:

Press Menu and turn on the transmitter to enter "SYS SETTING". Use up/down button to select "**RECEIVE DATA**", OK button is to enter editing.

### Steps:

1. Press OK to receive data.
2. Restart the transmitter after receiving the data and it works.

### 13.Sound

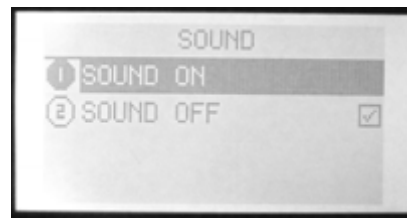
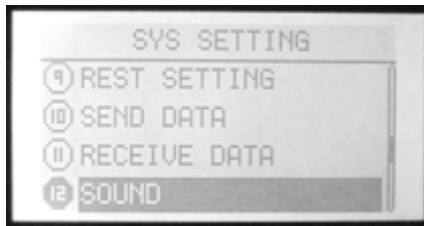

This function is to select the sound ON and OFF.

#### Setting Method:

Press Menu and turn on the transmitter to enter "SYS SETTING"  
Use up/down button to select "SOUND", OK button is to enter editing.

#### Steps:

1. Use +/- button to select ON and OFF.
2. Press OK button to confirm.
3. Press EXIT after setting.

## 14.CONTRAST SETTING

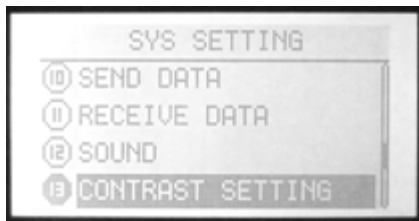

This function is to adjust the LCD brightness by increasing or decreasing the contrast value.

### Setting Method:

Press Menu and turn on the transmitter to enter “SYS SETTING”  
Use up/down button to select “**RECEIVE DATA**”, OK button is to enter editing.

### Steps:

1. Use +/- button to increase or decrease the value.
2. Press OK button for a while is to back default.
3. Press EXIT after setting.

## 16.LANGUAGE

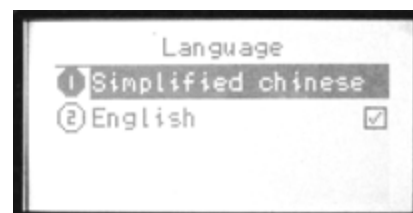
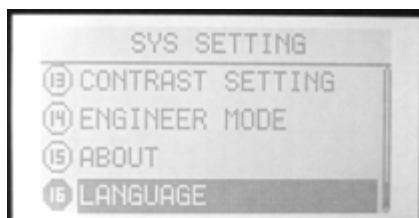

This function is to select the language. The selection is as shown in the picture, if only English or Chinese menu, the function is not exist.

## NORMAL SETTING(AIRPLANE)

### 1. MONITOR

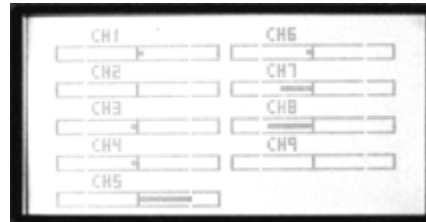
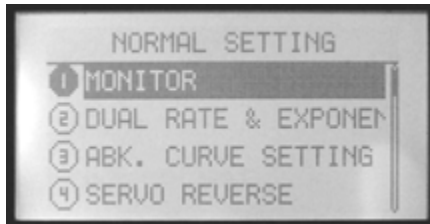

Monitor shows the servos' movement situation.

In PCMS, this function is to describe the 9 channels output.

In PPM, this function is to describe the first 8 channels output.

#### Setting Method:

Press menu button, enter system setting, the first function is the monitor.

## 2. DUAL RATE & EXPONENTIAL SETTING

### (1). AIL

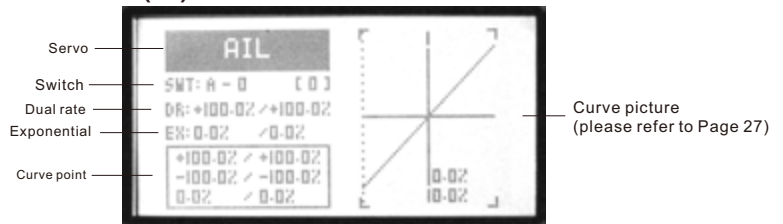
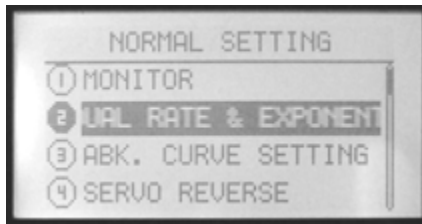

### (2). ELE

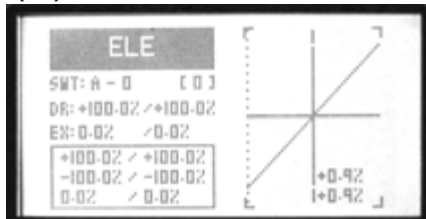

### (3). RUD

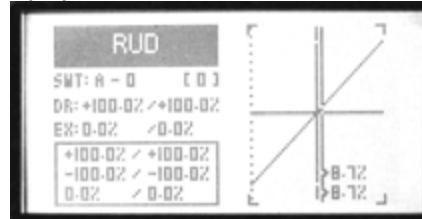

Dual rate is to adjust aileron, elevator and rudder travel range. The range is between 0%-120%.

Exponential setting is to adjust aileron, elevator and rudder sensitivity when the sticks are around the middle. The range is between -100% to +100%.

### Setting Method:

#### 1. Select channel

Aileron, elevator and rudder are selectable. Press +/- buttons to select channel, OK button to finish setting.

#### 2. Set the switch and its position(0,1,2)

Press direction button to select "SWT", edit it. +/- buttons can select function switch(A-F).

After selecting the function switch, press right direction button to enter the switch position setting, use +/- buttons to set.

#### 3. Set dual rate

Press direction button to select "D/R", edit it. Edit one or two parameter.

+/- buttons can increase or decrease the value.

Press the OK button is to back default.

#### 4. Set exponential

Press direction button to select "EX". Exponential can adjust aileron, throttle and rudder sensitivity as the stick at the middle.

#### 5. Set curve point (normal/advanced)

The box under "EX" shows the curve points.

Select "Curve setting" in More setting function list.

Please refer to Page 27 for detail curve setting.

#### 6. Press EXIT after all the values are finished setting.

### 3. ABK. CURVE SETTING

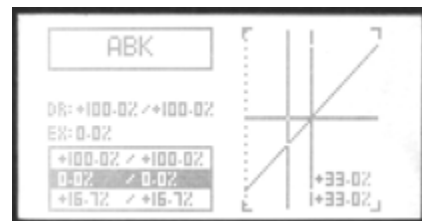
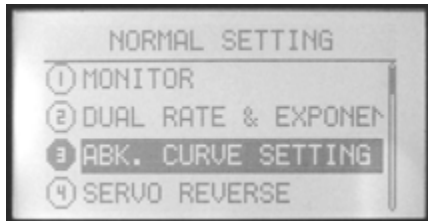

This function is used to make the glider speed down.

#### Setting Method:

Use up/down button to select **ABK. CURVE SETTING**, OK button is to enter editing.

#### Steps:

1. Use direction buttons to select editing part.
2. Use +/- button or OK button to switch the servo movement direction.
3. Press EXIT after setting.

## 4. SERVO REVERSE

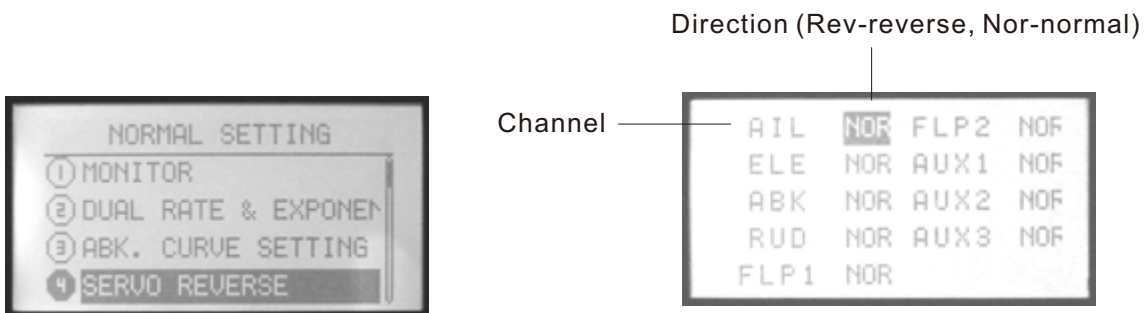

This function is to change the direction of the servos movement.

### Setting Method:

Use up/down button to select **SERVO REVERSE**, OK button is to enter editing.

### Steps:

1. Use direction buttons to select editing part.
2. Use +/- button or OK button to switch the servo movement direction.
3. Press EXIT after setting.

## 5. END POINT

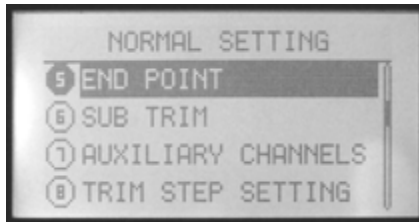

Channel	Side	Value	
AIL	L	100.02	R 100.02
ELE	D	100.02	U 100.02
ABK	L	100.02	H 100.02
RUD	L	100.02	R 100.02
FLP1	-	100.02	+ 100.02

FLP1	-	100.02	+ 100.02
FLP2	-	100.02	+ 100.02
AUX1	-	100.02	+ 100.02
AUX2	-	100.02	+ 100.02
AUX3	-	100.02	+ 100.02

It is to adjust the end of individual servo's travel. The range is from 0% to 120%.

### Setting Method:

Use up or down button to select **END POINT**, OK button is to enter editing.

### Steps:

1. Use direction buttons to select editing part.
2. Use +/- button or OK button to set the travel value. Press OK for a while backs to default.
3. Press EXIT after setting.

## 6. SUB TRIM

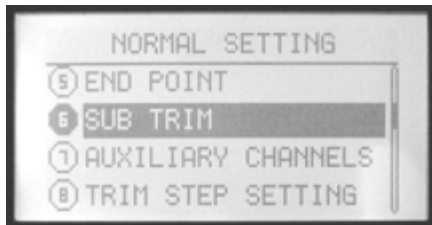

Channel	Value
FLP1	0
FLP2	0
AUX1	0
AUX2	0
AUX3	0

High/Low

AIL	0
ELE	0
ABK	0
RUD	0
FLP1	0

Sub trim makes small changes or corrections to the neutral position of each servo. Range is -120 to +120, default setting is 0.

We recommend that you center the digital trims before making Sub trim changes, and that you try to keep all of the Sub trim values as small as possible. Otherwise, when the Sub trims are large values, the servo's range of travel is restricted on one side.

### Setting Method:

Use up or down button to select **SUB TRIM**, OK button is to enter editing.

### Steps:

1. Use direction buttons to select editing part.
2. Use +/- button or OK button to set the trim value. Press OK for a while backs to default.
3. Press EXIT after setting.

## 7. AUXILIARY CHANNELS SETTING

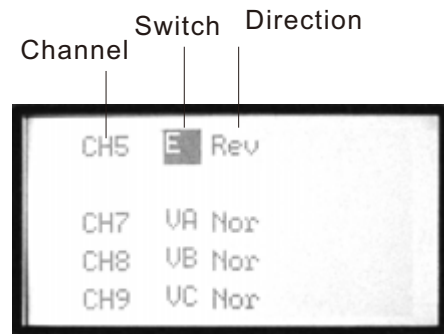
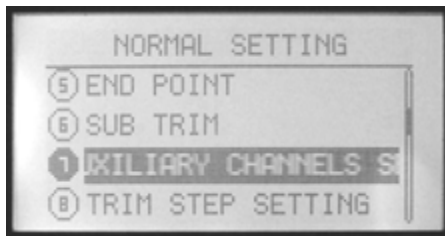

This function is for channel 5 to channel 9 function setting.

### Setting Method:

Use up or down button to select **AUXILIARY CHANNELS SETTING**, OK button is to enter editing.

### Steps:

1. Use direction buttons to select editing part.
2. Use +/- button to set the switches or knobs. The switches can be set from A to F, the knobs can be set as VA, VB, VC, VL, VR or none(-).
3. Use left or right direction button to set normal or reverse direction of every channel.
4. Press EXIT after setting.

## 8. TRIM STEP SETTING

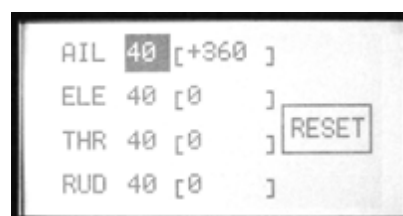
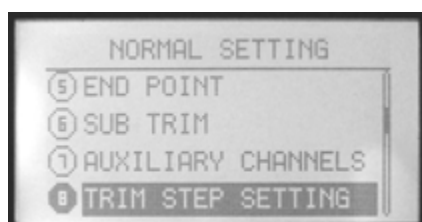

This function is to change the rate at which the trim moves when the TRIM LEVER is activated. The range is from 1 to 250. Generally larger trim steps are for models with larger control throws or for first flights to ensure sufficient trim to properly correct the model. Smaller trim steps are later used to allow very fine adjustments in flight.

### Setting Method:

Use up/down button to select **TRIM STEP SETTING**, OK button is to enter editing.

### Steps:

1. Use direction buttons to select editing part.
2. Use +/- button to adjust the size of the step. Repeat as desired for other channels. If you select RESET, the current channel trim value change to 0.
3. Press EXIT after setting.

## 9. FLAPERON

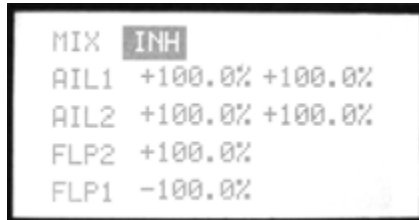
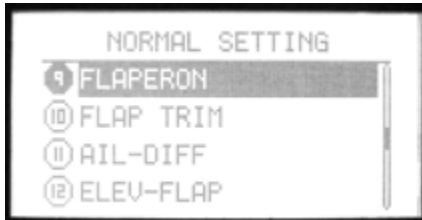

FLAPERON mixing function uses on servo on each of the two ailerons, and uses them for both aileron and flap function.

### Setting Method:

Use up/down button to select **FLAPERON**, OK button is to enter editing.

### Steps:

1. Use direction buttons to select editing part.
2. Use +/- button to set value. Press OK button for seconds can back default.
3. Press EXIT after setting.

## 10. FLAP TRIM

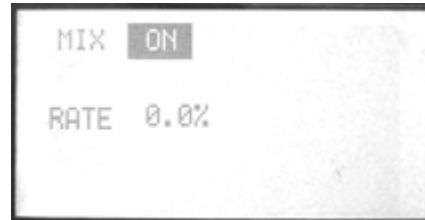
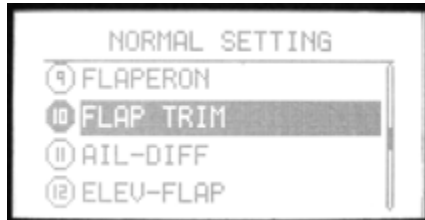

FLAP TRIM assigns the primary flaperon control to allow trimming in flight of the flap action of flaperons.

### Setting Method:

Use up/down button to select **FLAP TRIM**, OK button is to enter editing.

### Steps:

1. Use direction buttons to select editing part.
2. Use +/- button to set value. Press OK button for seconds can back default.
3. Press EXIT after setting.

## 11. AIL-DIFF

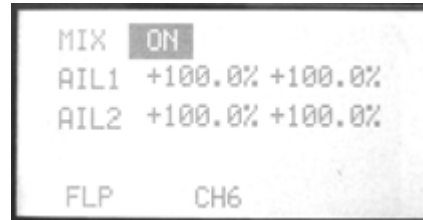

Aileron differential(AIL-DIFF) is primarily used on 3-servo wings, with one servo operating inboard flap(s) on Ch6, and AIL-DIFF controlling proper aileron operation of 2 aileron servos, plugged into Ch1 and Ch7.

### Setting Method:

Use up/down button to select **AIL-DIFF**, OK button is to enter editing.

### Steps:

1. Use direction buttons to select editing part.
2. Use +/- button to set value. Press OK button for seconds can back default.
3. Press EXIT after setting.

## 12. ELEV-FLAP

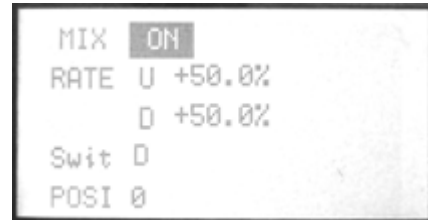

ELEV-FLAP mixing is the first pre-programmed mix we'll cover. This mix makes the flaps drop or rise whenever the elevator stick is moved. It is most commonly used to make tighter pylon turns or squarer corners in maneuvers. In most cases, the flaps droop (are lowered) when up elevator is commanded.

### Setting Method:

Use up/down button to select **ELEV-FLAP**, OK button is to enter editing.

### Steps:

1. Use direction buttons to select editing part.
2. Use +/- button to set value. Press OK button for seconds can back default.
3. Press EXIT after setting.

### 13. FAIL SAFE



This function is to set responses in case of loss of signal or low RX battery.

#### Setting Method:

Use up/down button to select **FAIL SAFE**, OK button is to enter editing.

#### Steps:

1. Use direction buttons to select editing part.
2. Use +/- button to select "hold" or "0.0%"
3. Press OK button to confirm the current parameter.
4. Press EXIT after setting.

## 14. TIMER

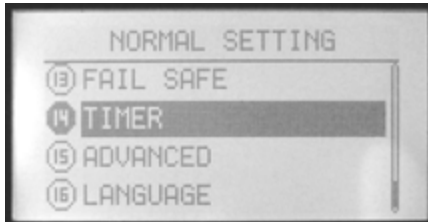

The flight time of every helicopter is different according to the different tank of fuel, engine, ESC, etc. Timer function can alarm you to land before the fuel lacks.

The transmitter can set 3 timers (A, B, C). The longest time can be set as MM99SS59. The countdown timer can alarm user before 10 minutes. The alarm will become 2S/1S from 1S/1S in the last 10 seconds. When the countdown timer is 0, the time will add up.

The timer can be seen in the opening screen. Any switch can be set to control the begin and stop of the time.

### Setting Method:

Use up/down button to select **TIMER**, OK button is to enter editing.

### Steps:

1. Use direction buttons to select editing part.
2. Set timer. WFT09S can set 3 timers (A, B, C).
3. Use +/- button to set MM..SS... Press OK button for seconds can back to default.
4. Use +/- button to set model.
5. Use +/- button to set control(CTRL).
6. Use +/- button to set the position which can active this function.
7. Press EXIT after setting.

## 15. Language

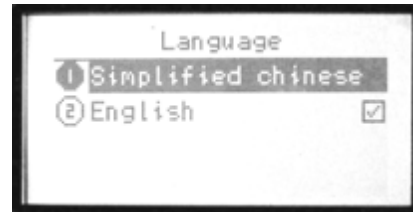

This function is to select the language. There are 5 language selectable. For example, the selection is as shown in the picture.

## 16. ADVANCED



To realize an idea fly, there are 20 advanced function in ADVANCED.

### Setting Method:

Use up/down button to select ADVANCED, OK button is to enter editing. +/- button can turn page.  
About each advanced functions please read the following pages.

## ADVANCED function introduction

### (1). CURVE SETTING

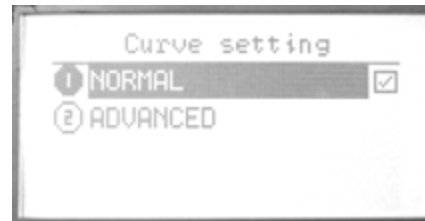
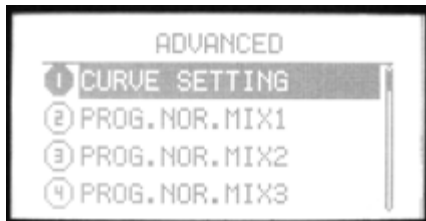

There are 2 kinds of setting, Normal and Advanced.  
Please refer to page 27.

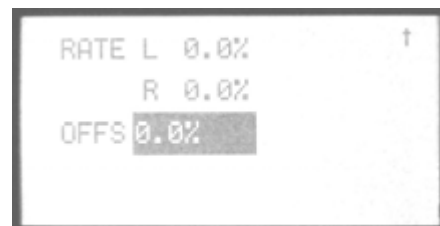
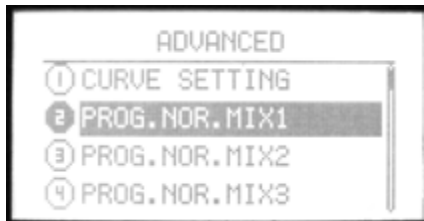
**(2)-(8). PROG. NOR. MIX1-7**

The mix program is to adjust the flying pose. There are 7 series programs with the same setting method. You can set one mix and one mix with another one mix.

**Setting Method**

Use up/down button to select **PROG. NOR. MIX**, OK button is to enter editing.

**Steps:**

1. Use direction buttons to select editing part. Set any two channels mix.
2. Use +/- button to active or inhibit "Mix".
3. Use +/- button to active or inhibit "Link" and "TRIM".
4. Use +/- button to active or inhibit "CTRL".
5. Use +/- button to set the control switch position.
6. Press EXIT after setting.

**(9)-(12). PROG. CUR. MIX1-4**

There are 4 curve mix program, the curve is made up by 2 to 10 point.

**Setting Method:**

Use up/down button to select **PROG. CUR. MIX**, OK button is to enter editing.

**Steps:**

1. Use direction buttons to select editing part. Set any two channels mix.
2. Use +/- button to active or inhibit "Mix".
3. Use +/- button to active or inhibit "Link" and "TRIM".
4. Use +/- button to active or inhibit "CTRL".
5. Use +/- button to set the control switch position.
6. Set the curve point. (Normal/Advanced). Please refer to page 27.
7. Press EXIT after setting.

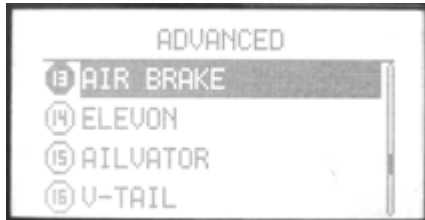
**(13). BUTTERFLY**

AIR BRAKE simultaneously moves the flaps, twin ailerons and elevators, and is usually used to make steep descents or to limit increases in airspeed in dives.

**Setting Method:**

Use up/down button to select **AIR BRAKE**, OK button is to enter editing.

**Steps:**

1. Use direction buttons to select editing part.
2. Use +/- button to active or inhibit "Mix".
3. Use +/- button to set Swit, POSI. Press OK button for seconds can back default.
4. Use +/- button to set CTRL (MAN/ THR).
5. Use +/- button to set delay value. Press OK button for seconds can back default.
6. Press EXIT after setting.

## (14). ELEVON

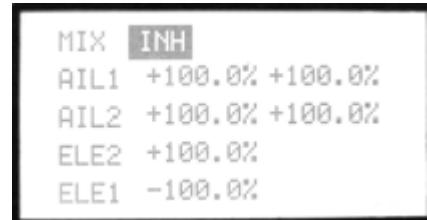
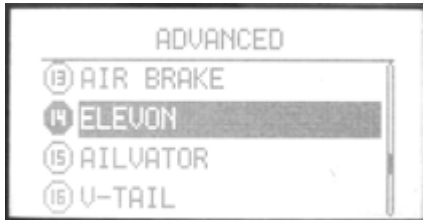

This function used with delta wings, flying wings, and other tailless aircraft that combine aileron and elevator functions, using two servos, one on each elevon. The aileron/elevator responses of each servo can be adjusted independently.

### Setting Method:

Use up/down button to select **ELEVON**, OK button is to enter editing.

### Steps:

1. Use direction buttons to select editing part.
2. Use +/- button to set value. Press OK button for seconds can back default.
3. Press EXIT after setting.

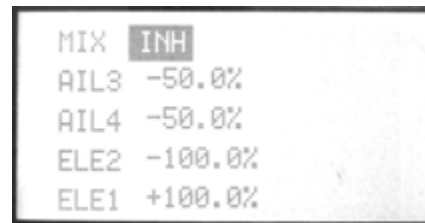
**(15). AILVATOR**

AILEVATOR mixing function uses one servo on each of the two elevators, and combines the elevator function with the aileron function(unless aileron travel is set to 0).

**Setting Method:**

Use up/down button to select **AILVATOR**, OK button is to enter editing.

**Steps:**

1. Use direction buttons to select editing part.
2. Use +/- button to set value. Press OK button for seconds can back default.
3. Press EXIT after setting.

## (16). V-TAIL

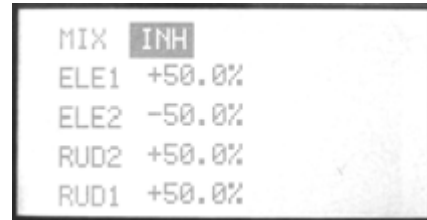
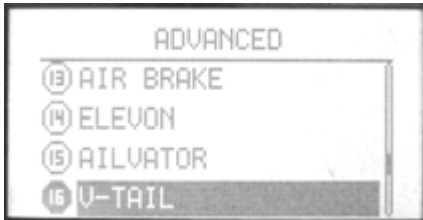

V-TAIL mixing is used with v-tail aircraft so that both elevator and rudder functions are combined for the two tail surfaces. Both elevator and rudder travel can be adjusted independently on each surface.

### Setting Method:

Use up/down button to select **V-TAIL**, OK button is to enter editing.

### Steps:

1. Use direction buttons to select editing part.
2. Use +/- button to set value. Press OK button for seconds can back default.
3. Press EXIT after setting.

**(17). START OFS**

This function is used to offset the aileron, elevator, and flap servos to the position that provides maximum lift during launch. Normally the ailerons and flaps are drooped about 20-30, with the flaps drooped slightly more to prevent tip-stalling on tow. The elevator can also be offset in oo trim out any pitch changes caused by the flap and aileron presets.

**Setting Method:**

Use up/down button to select **START OFS**, OK button is to enter editing.

**Steps:**

1. Use direction buttons to select editing part.
2. Use +/- button to set value. Press OK button for seconds can back default.
3. Press EXIT after setting.

**(18). SPEED OFS**

This function is used to offset the aileron, elevator, and flap servos for minimum drag in cruise and high-speed flight. Normally the ailerons and flaps are raised about 3-5.

**Setting Method:**

Use up/down button to select **SPEED OFS**, OK button is to enter editing.

**Steps:**

1. Use direction buttons to select editing part.
2. Use +/- button to active or inhibit **T** his function. Press OK button for seconds can back default.
3. Press EXIT after setting.

**(19). Code matching**

Please refer to page 16.

## TO THE PILOT

**WFT09SII** Is the 2.4G version which includes helicopter, airplane and glider function. Thank you for using the radio systems.

We welcome your valuable advice and we will continue developing the radio.

Welcome to contact us!

[Www.wflysz.com](http://www.wflysz.com)

[sales@wflysz.com](mailto:sales@wflysz.com)

Tel: 0086 755 26581817

Fax: 0086 755 26581821

**WFLY<sup>®</sup>**

***[www.wflysz.com](http://www.wflysz.com)***