

More product information,  
please follow the WeChat official  
account above

10 Channels Digital Proportional R/C System

# ET10

# Instruction Manual

# **WFLY**®

---

Thank you for using WFLY products!

- Please read this product manual carefully before using this product!
- Please use this product properly!

The R/C model is not a toy, for safety, please do not fly in crowded places!



Please read the following instructions carefully before use to ensure safely use of the product

---

## Safety Caution

- 6 Symbols Definition
- 7 Flying Notices
- 8 Battery
- 8 Trainer
- 8 USB Interface

## Before Use

- 9 Product Features
- 9 Basic Configuration
- 10 Each Parts Name Of Transmitter
- 11 Switch Configuration And Types
- 11 The Travel Of Antenna Direction Adjustment

## Basic Operation

- 12 Home Interface Operation
- 13 Touch Screen Operation
- 14 Indicator Light Of Transmitter
- 14 Stick Adjust Instruction
- 15 Stick Adjustment
- 16 Receiver Instructions
- 17 Receiver And Servo Link Example
  - 17 -airplane
  - 18 -glider
  - 19 -helicopter
  - 20 -multicopter

## Models Basic Setting Sequence

- 21 -airplane and glider
- 22 -helicopter

 **System Setting**

24	Model Select	Save multiple sets of set parameters and switch freely when needed
24	Model Name	Name a group of model parameters
25	Model Type	Select helicopter, airplane or multicopter
26	Model Copy	Copy one group of model parameters to another group of model parameters
26	Model Reset	Reset a group of model parameters to initial value
27	Low Voltage	Set low battery alarm point
27	Sound	On/Off sound
27	Backlight	Adjust backlight brightness, light time
28	Trainer/Simulator	Set trainer or simulator function
29	User Name	Input letter or number, as a user name
29	Back Color	Modify the screen back colour
29	Calibration	Calibrate the neutral point of ailerons, elevations, accelerators, directional channel rocker and the position of the upper, lower, left and right endpoints
30	Stick Mode	Select suitable operation stick mode
30	Language	Select English or Chinese interface language
30	Factory Reset	Reset all parameters of transmitter
30	Telemetry Unit	Display the unit setting
31	Screen Cal	Calibrate the panel screen
31	Information	Transmitter system information
32	Screen Lock	Screen lock mode
32	Boot Warning	Startup alarm function setting

 **Linkage Setting**

33	Link Step	Transmitter and receiver link
34	Telemetry	Display the set sensor data
34	Servo Frequency	The servo working frequency
35	Range Check	Reduce the power to remote control range check
36	Fail Safe	When the receiver lost the signal, it automatically loads the preset scheme for the body action safety protection
37	W.BUS Servo	Set servo
37	PPM/W.BUS	Switch the output mode of receiver
37	Rx Port Setting	Set the output channel of receiver port

 **General Menu**

38	Monitor	Monitoring and displaying the output status of each channel
38	Servo Reverse	Set each channel reverse to match the neutral point of each model channel
38	Sub-Trim	Adjust the neutral point of each channel
39	Timer	Set flying alarm time to help remind battery or fuel capacity
40	Dual Rate	Adjust the channel output value to adapt the dual rate of each model channel
41	End Point	Channel end point and limit position
41	Trim Step	Set the trimming step value of each channel
41	Aux Channel	Customize the switch of 5-10 channel
41	Channel Delay	Set the delay value
42	Program Mix1-3	Mixing the output of 2 random channels
42	Curve Mix1-2	Mixing the 2 random channels of curve controlled



## Model Menu\Airplane

43	Throttle Hold	Hold the throttle output status
43	AIL Differential	Adjust the differential of AIL1 and AIL2
44	Aileron 2	Assign another AIL channel
44	Fly Mode	Motion mode assignment
44	Throttle Cut	To make instant throttle cut after flying
45	Throttle Curve	Adjust the linear relation of throttle
45	Flap Trim	Adjust flap end point, change flap channel separately, control mix will synchronize
46	ELE to Flap	Adjust elevator and flap for one way mixed control
46	Flaperon	Adjust the step of flap and aileron
47	Elevon	Combined aileron and elevator mixed control
48	Airbrake	
49	Ailvator	Adjust ELE and AIL one way mix
49	V-Tail	Adjust elevator and rudder mixed control



## Model Menu/Helicopter

50	Throttle Hold	Hold the throttle output status
51	Throttle Curve	Adjust the linear relation of throttle
51	Swash	Select swash types and set swash parameters
52	Fly Mode	Motion mode assignment
52	Throttle Cut	To make instant throttle cut after flying
53	Pitch Curve	Adjust the pitch output linear relation
53	Idle Down	Idle speed control
53	Governor	Governor special adjustment
	Gyro	Adjust the gyro sensitivity under each different fly mode



## Model Menu/Multicopter

54	Switch Program	
54	Throttle Hold	Hold the output status of throttle
55	Fly Mode	Motion mode assignment
55	Throttle Curve	Adjust the throttle output linear relation



## Symbols Definition

Pay special attention to the safety information of the following symbols



If without a proper operation, it may cause dangerous accident or seriously injury or may even cause death.



Prohibitions



Compulsory Items



If without a proper operation, it may cause dangerous accident or seriously injury or may even cause death, and it may cause slight hurt or probability cause bodily injure!



If without a proper operation, it may cause less possibility to serious hurt, but it may cause hurt or bodily injure.

## Flying Notices

### Disclaimer & Warning:

User should be responsible for any consequences caused by using the product. WFLY shall not be liable for any directly or indirectly damage, injury and any legal liability, User shall comply with all guidelines including but not limited to this document. Please follow the local laws and regulations for regular flight activities. Do not use this product to carry out personal safety, property safety or other bad flight behaviors.



To ensure the safety of yourself and others, please observe the following precautions:

Charge the batteries! Check transmitter and receiver battery levels and always recharge the batteries before each flying session. A low battery will soon die potentially, causing loss of control and a crash. When you begin your flying session, reset your ET10 built-in timer, and during the session pay attention to the duration of usage.

Be careful when flying near power line, High structures or communication facilities, as there may be radio interference around.



Beginners should pay particular attention to the following safety precautions! Please read carefully!

It is forbidden to fly when in poor condition such as fatigue and drunkenness.

It is forbidden to fly in bad weather such as rain and gale.

It is forbidden to fly near high voltage lines, communication base stations and places where people gather or activate.

It is forbidden to fly in airports and other places where fly is forbidden.

Before flying, test the equipment, check whether the transceiver system and the aircraft are normal;

When flying, make the interface of transmitter in the initial interface for preventing the change of parameters by mistake;

After flying, turn off the receiver primarily and then turn off the transmitter for protecting people from the fail-safe function.

More debugging, more testing, less loss, less damage!



Power on and off sequence of transmitter and receiver!

Power on step:

Firstly turn on the transmitter (ensuring the minimum throttle position),

Secondly Turn on the receiver.

Power off:

Firstly turn off the receiver, Secondly turn off the transmitter.

Transmitter and receiver low voltage may cause fail safe danger.

Notice: The transmitter will display the warning interface, please pay attention to the transmitter prompt! Improperly operation may cause accident injury to user.



## Battery



It is important to understand the operating characteristics of Li-po batteries. Long term storage (no less than 3 months), storage temperature  $\leq 45$ , general storage voltage 3.7-3.9V. Failure to follow the proceeding precautions can quickly result in severe, permanent damage to the batteries and possibly result in a FIRE!

1. Do not attempt to disassemble LiFe packs or cells.
2. Do not allow LiFe cells to come in contact with moisture or water at any time.
3. Always provide adequate ventilation around LiFe batteries during charge, discharge, while in use, and during storage.
4. Do not leave a LiFe battery unattended at any time while being charged or discharged.
5. Do not attempt to charge LiFe batteries with a charger that is NOT designed for LiFe batteries, as permanent damage to the battery and charger could result.
6. Always charge LiFe batteries in a fireproof location. Do not charge or discharge LiFe batteries on carpet, a cluttered workbench, near paper, plastic, vinyl, leather or wood, or inside an R/C model or full-sized automobile! Monitor the charge area with a smoke or fire alarm.
7. Do not charge LiFe batteries at currents greater than the "1C" rating of the battery ("C" equals the rated capacity of the battery).
8. Do not allow LiFe cells to overheat at any time! Cells which reach greater than 140 degrees Fahrenheit (60°) should be placed in a fireproof location.
9. LiFe cells will not charge fully when too cold or show full charge.
10. It is normal for the batteries to become warm during charging, but if the charger or battery becomes excessively hot disconnect the battery from the charger immediately!! Always inspect a battery which has previously overheated for potential damage, and do not re-use if you suspect it has been damaged in any way.
11. Do not use a LiFe battery if you suspect physical damage has occurred to the pack. Carefully inspect the battery for even the smallest of dents, cracks, splits, punctures or damage to the wiring and connectors. DO NOT allow the battery's internal electrolyte to get into eyes or on skin—wash affected areas immediately if they come in contact with the electrolyte. If in doubt, place the battery in a fire-proof location for at least 30 minutes.
12. Do not store batteries near an open flame or heater.

13. Do not discharge LiFe batteries at currents which exceed the discharge current rating of the battery.

14. Always store LiFe cells/packs in a secure location away from children.



Transmitter: Et10 adopts the power supply mode of lithium battery, and the working voltage adapts to the stroke of 7.4V-8.4V. Using a power supply that exceeds the operating voltage stroke may burn the machine!

The USB interface of the ET10 can be charged. Please charge the battery with a USB output charge like mobile phone charge, ect. (Standard: 5V/1.5V)

Receiver: (RF209S) The receiver's operating voltage adapts to the trip 3.7V-8.4V, with anti-reverse protection slot (power input pole, positive and negative reverse protection). With a power supply that exceeds the operating voltage stroke, the receiver will burn out.

## Trainer



Transmitter trainer port.

The trainer port is with 3.5mm audio port output mode. This suite is without the coach data line. If you want to use the trainer function, you need to purchase the trainer data line separately!

Warning: This port is only used for trainer data transmission. It is forbidden to insert the power supply (high voltage) terminal to the port to avoid damage for the transmitter.

Suggestion: You can consult the purchase line at WFLY Technology Taobao Store or other model online stores or physical stores.

## USB Interface



Transmitter USB interface: ET10 is with standard USB interface, support interface charge and update!

Standard: Support 5V, 1.5A. (Notice: The interface only support USB standard voltage, non-standard input such as modified interface may damage the machine and will void the warranty! Please use the charger carefully! )

Receiver USB port: RF209S USB interface is only used as upgrading data port, it is forbidden to insert the power supply (high voltage) terminal to the USB interface to avoid damage for the receiver.



## Product Features

### Transmitter

Model: ET10  
 Channel: 10 channels  
 Working voltage: 7.4V (2cell Lithium battery)  
 Working current: ≤260mA  
 Applications: Helicopter, Airplane, Multi-Rotors, Vehicle, Ship  
 Resolution: Full Channel 4096 Resolution  
 Band: 2.4GHz (Bidirectional)  
 Frequency Hopping: New FHSS Frequency Hopping (64points, 3.6ms)  
 Storage: 20 models  
 Programming: 5 Groups Mixed Control  
 Language: Chinese, English  
 Upgrade: USB online upgrade  
 Display: 3.5inch touch, 480\*320, TFT color display

### Receiver

Model: RF209S  
 Frequency: 2.4 GHz  
 Working Voltage: 3.7 V-8.4 V  
 Working Current: 75 mA  
 Applications: Helicopter, Airplane, Multi-Rotors, Vehicle, Ship  
 Resolution: Full Channel 4096 Resolution  
 PWM: 9 Channel (Mode A)  
 PPM: Support  
 W.BUS: Compatible with S.BUS  
 W.BUS2: Telemetry Sensor Input  
 Bidirectional Transmission: Support  
 Fail Save: Support  
 Online upgrade: Support  
 External voltage detection: DC 0-96V  
 Size: 27×14×51mm  
 Weight: 14.6g

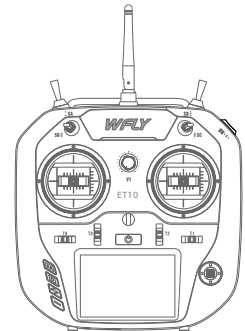

## Basic Configuration

Transmitter: ET10 remote controller x1  
 Receiver: RF209S Receiver x1 (External power inspection wire x1)

Accessory :  
 Lanyard x1

Others :  
 Summary manual file x1  
 Warranty card x1

\*WFLY will not notify further if any configuration changes.

Transmitter

Receiver

Lanyard

Summary manual x1

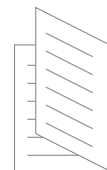
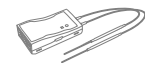



# Each Parts Name of Transmitter

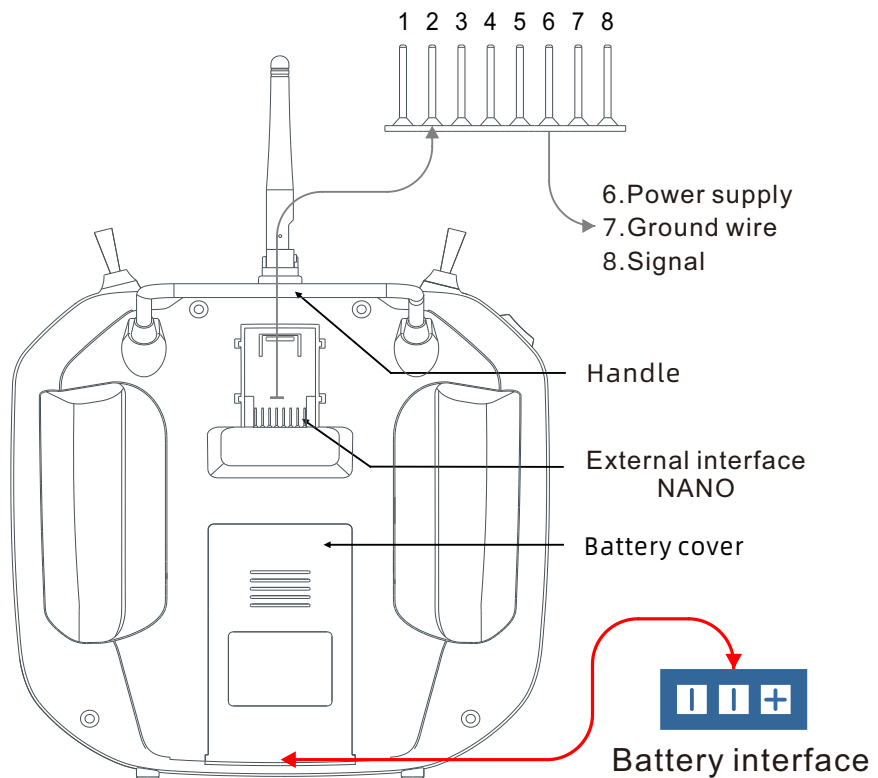
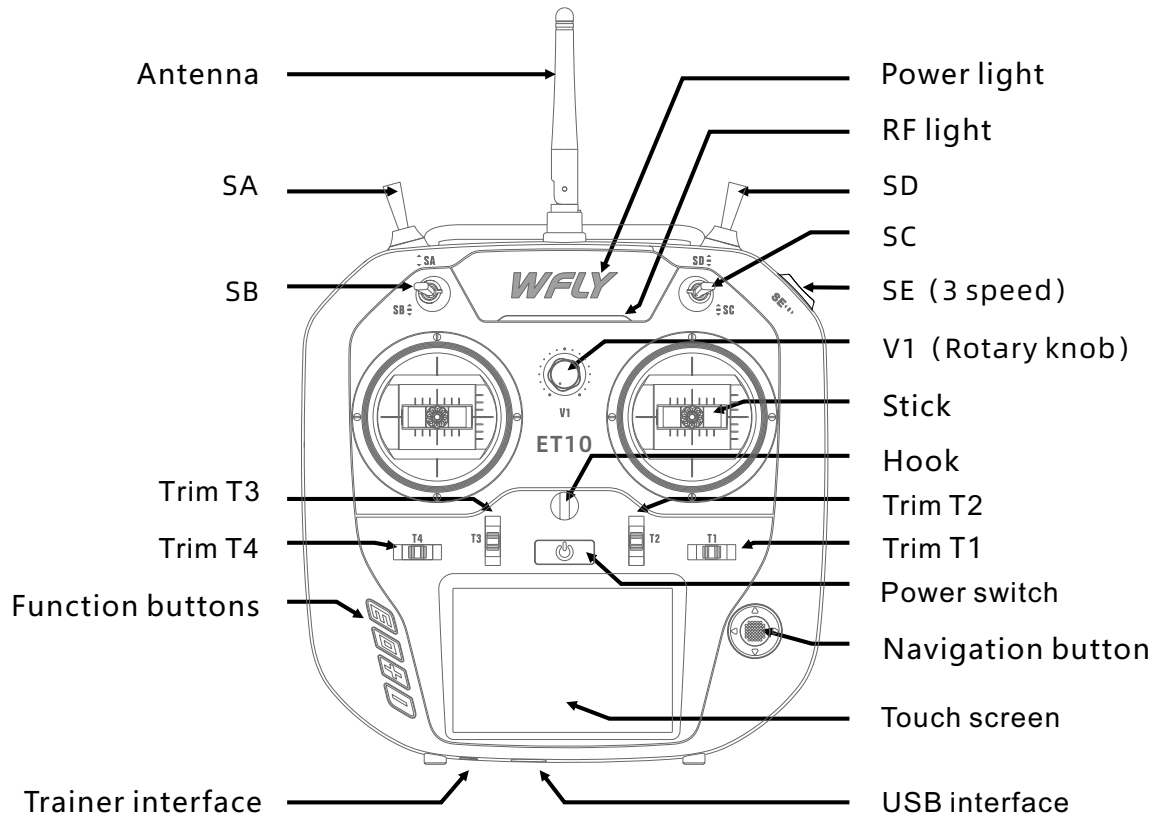

## Switch Configuration And Types

Power switch: Click and hold for about 2 seconds to open/shut down  
 T1-T4: Trim key (User defined function)  
 SA: Short lever 2 positions (User defined function)  
 SB: Long lever 2 positions (User defined function)  
 SD: Short lever 3 positions (User defined function)  
 SE: Long lever 2 positions reset (User defined function)  
 SE: 3 Speed switch (user-defined)  
 V1: Rotary knob (User defined)



HOME: Function key, slightly click to return to standby interface, click and hold for 2 seconds to turn on the monitor interface.

EXIT : Return key, slightly return to the superior interface;  
 Screen locking state : Press EXIT key for 2 seconds to toggle,  
 Advanced Lock state : Press EXIT key ten times, and then press it for 2 seconds to unlock.

+: Increase key, parameter increment, switch status  
 -: Decrease key, parameter decrement, switch status



Up/down/left/right: Direction key  
 Middle: Slightly click to confirm, press and hold to reset parameters (value)

## The Travel Of Antenna Direction Adjustment

The antenna activity of the transmitter is limited by the stroke. If the activity is exceeded, the antenna will be damaged.

The active travel indication of the antenna is as following:

Left and right movement 180°

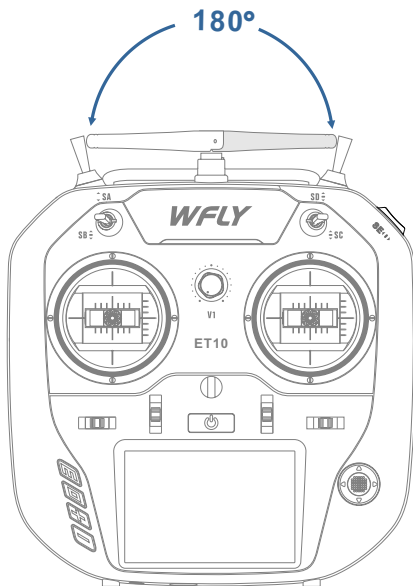

Front and up movement 180°

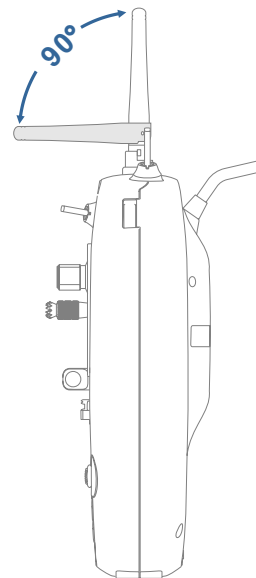



## Home Interface Introduction

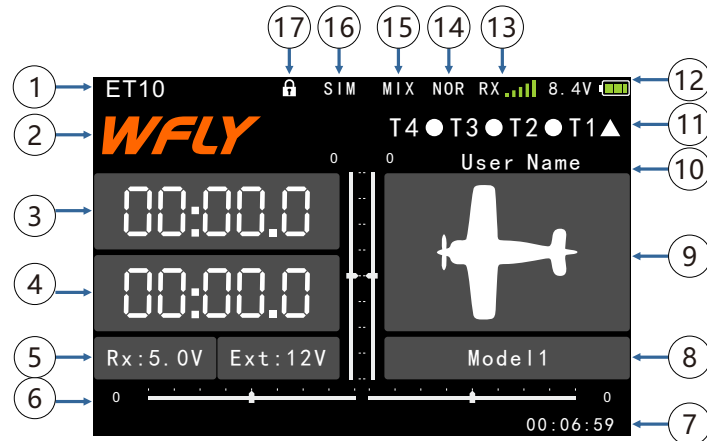

## Operation and Introduction

1. Transmitter model
2. LOGO, Click to enter main menu
3. Normal Timer :Click and hold for reset,slightly click for start/pause
4. Mode Timer:Click and hold for reset,status is set by(Timer)menu
5. Voltage:Receiver voltage,external
5. Return data(External battery)
6. Trim monitor:display active trimming status
7. Boot time:The accumulation boot time , shutdown reset
8. Model name: Click to enter model selecting interface
9. Model types:Click to enter current machine type Interface
10. User name:click into user defined name
11. Trim status:display T1-T4 trim status(T1-T4 while the switch being used),more details please refer to(Aux Channel)and[Trim Setting]

- ▲ means the position is "up"
- means the position is "neutral"
- ▼ means the position is "down"

12. Transmitter battery capacity
13. Receiver signal strength
14. Fly mode(Throttle lock,normal,Idle1,Idle2)
15. Mixing:Display the mixing after ACT the mixing function
16. Working mode:Display then ACT mode(Trainer,simulator,student)
17. Screen locking state : Press EXIT key for 2 seconds to toggle,  
**Advanced Lock state** : Press EXIT key ten times, and then press it for 2 seconds to unlock.

## Touch Screen Operation

ET10 uses 3.5 inches resistance touch screen, which makes ET10 operation more flexible and efficient.



Touch the touch screen softly with the stylus pen or your fingertips. Plastic film is attached to the touch screen. Please be careful so that you don't scratch the touch screen with anything hard such as a metal object. Don't push the touch screen with excessive force or drop anything on the panel.

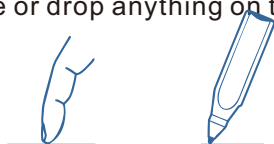

### Operate Demonstration

Menu Operation: Click enter into the relative interface

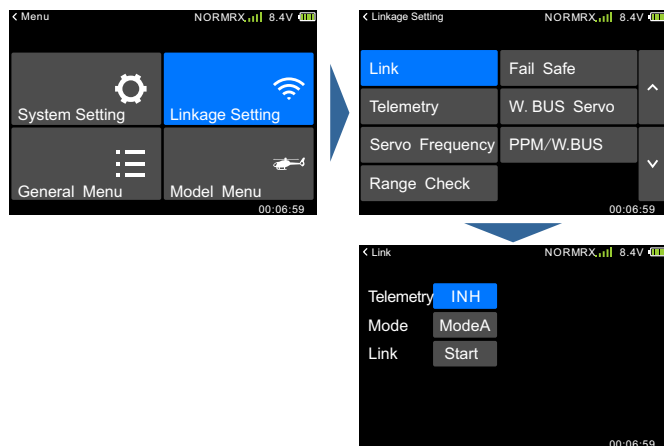

Status Switch: Click into switch status

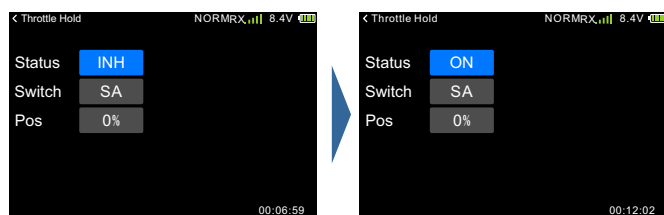

Parameters Setting:

- 1 Data setting: Click and pop up the upper right setup key, click again the key to return the set value .
- 2 Switch, function type setting: Click to switch.

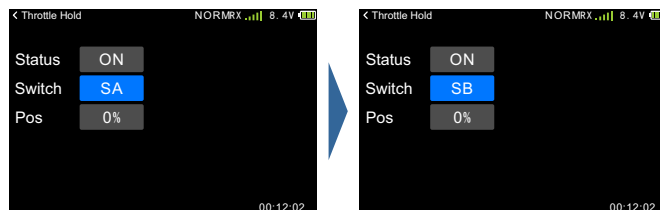
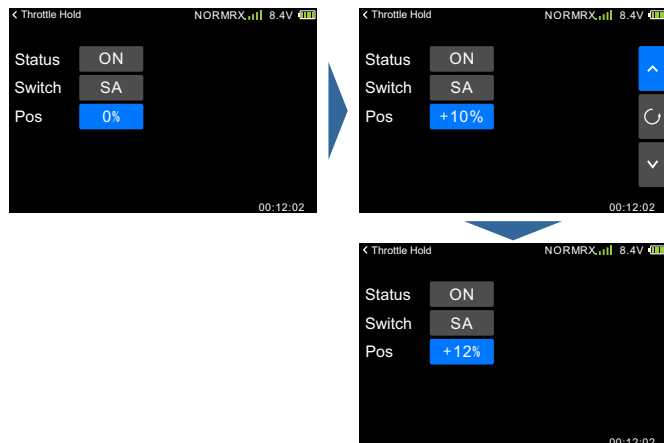

### Key function instruction

- 1 Page up and down key: Used for turning pages and switching lists
- 2 Up and down key: Displays when entering into value setting, used for editing parameters
- 3 Reset key: between UP/Down/+/- keys, used for reset the default

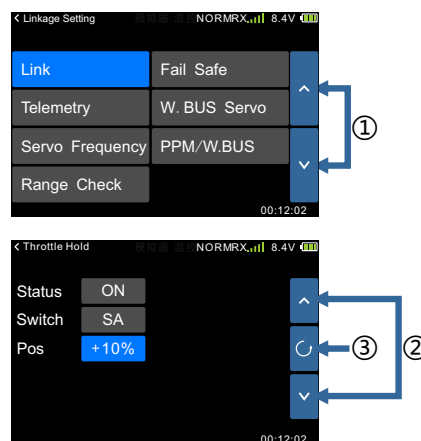

Popup prompt: When the operation changes important parameters, the selection box will pop up for secondary confirmation. The default "No" is selected.

Example: The interface model selecting operation of (Model Selecting)!Click a model selecting, then pops up a selecting box, and then click confirm key means select "No".

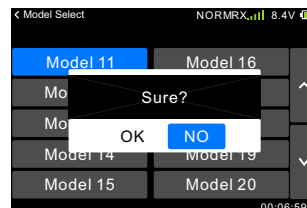



### Indicator Light of Transmitter

	LED	Status	
Power light		Power light on	Turn on, charging
		Power light off	Turn off
RF light		RF light off	Turn off, student or simulator mode
		Off light on	Normal linkage, trainer or normal mode
		RF light flashes	Enter link status

### Stick Adjustment

#### Stick head height adjustment

Tools : 1.5mm socket screwdriver:

Steps:

1. Loosen the upper section head counterclockwise
2. Then twist the lower head to adjust the height
3. Twist the upper head clockwise to lock it

#### Stick feel and function adjustment

ET10 uses the newly developed four-bearing assembly to trim the feel!

Uncover the silicone sheet on the back and adjust the feel directly.

Note: Do not use excessive force or over twist the number of turns when adjusting the screw. Otherwise, the structure assembly would be twisted off and the screw may fall off, resulting in irreversible damage.

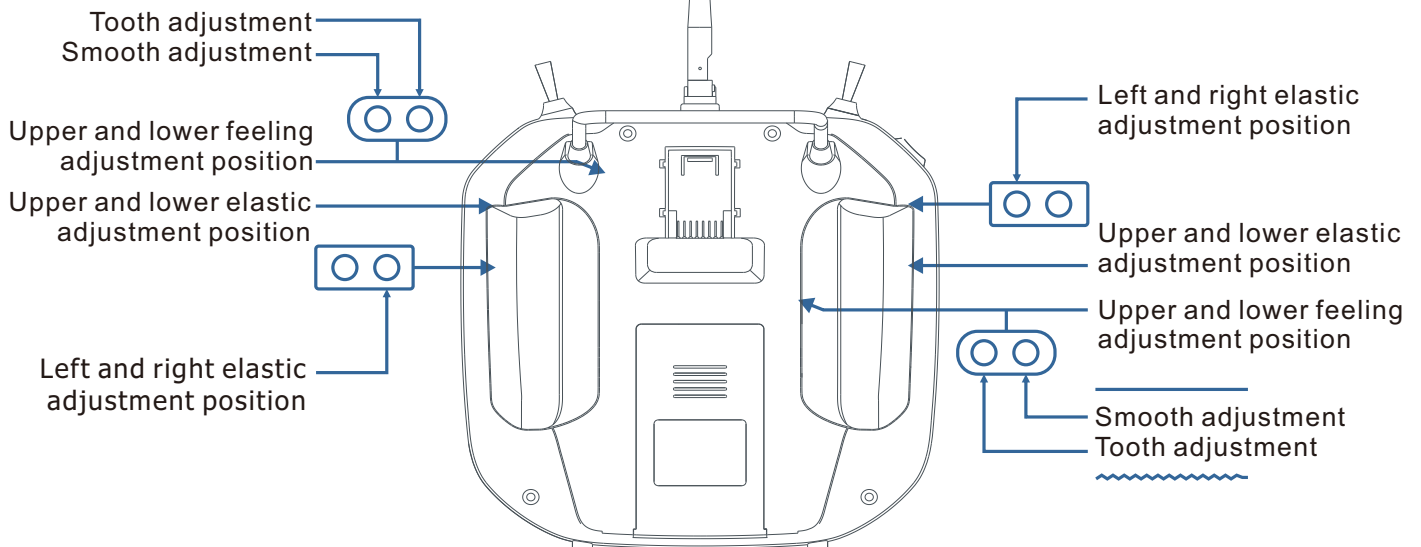
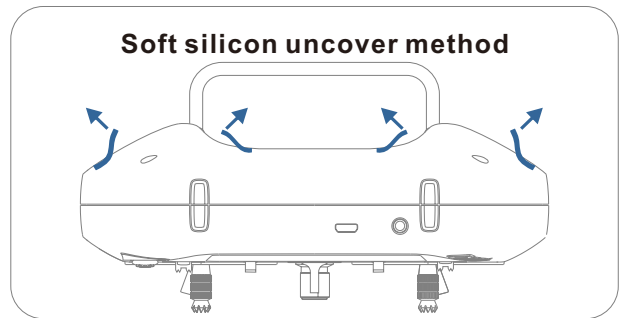
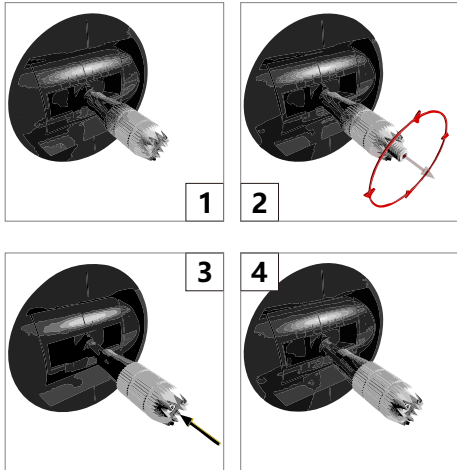

## Stick Adjustment

### Left and right stick mode replacement method

It is not recommended to replace the left and right sticks by yourself, otherwise the transmitter may be damaged. (Your free warranty would be lost if you replaced your left and right sticks )

Required tools: 3 mm cross screwdriver, 1.5 mm hex driver

First open the transmitter housing and then follow the instructions shown below:

1 Loosen the bearing housing screws (the screws do not need to be fully retracted), then remove the spring, bracket 7 and bracket 5 and tighten the screws; then remove the removed spring, bracket 7 and bracket 5 in another assembly corresponding position (remove the bearing housing screw before assembly), The tightness of the stick can be changed by adjusting the height of screw 3.

2 Remove the screw of the throttle reed, the throttle reed and the throttle sleeve, and install them in the corresponding position of the other assembly. According to your own habits, select the type of throttle sliding (toothed and smooth) and adjust the screw (screw 1 or The height of the screw 2) makes the damping of the throttle conform to your own habits.

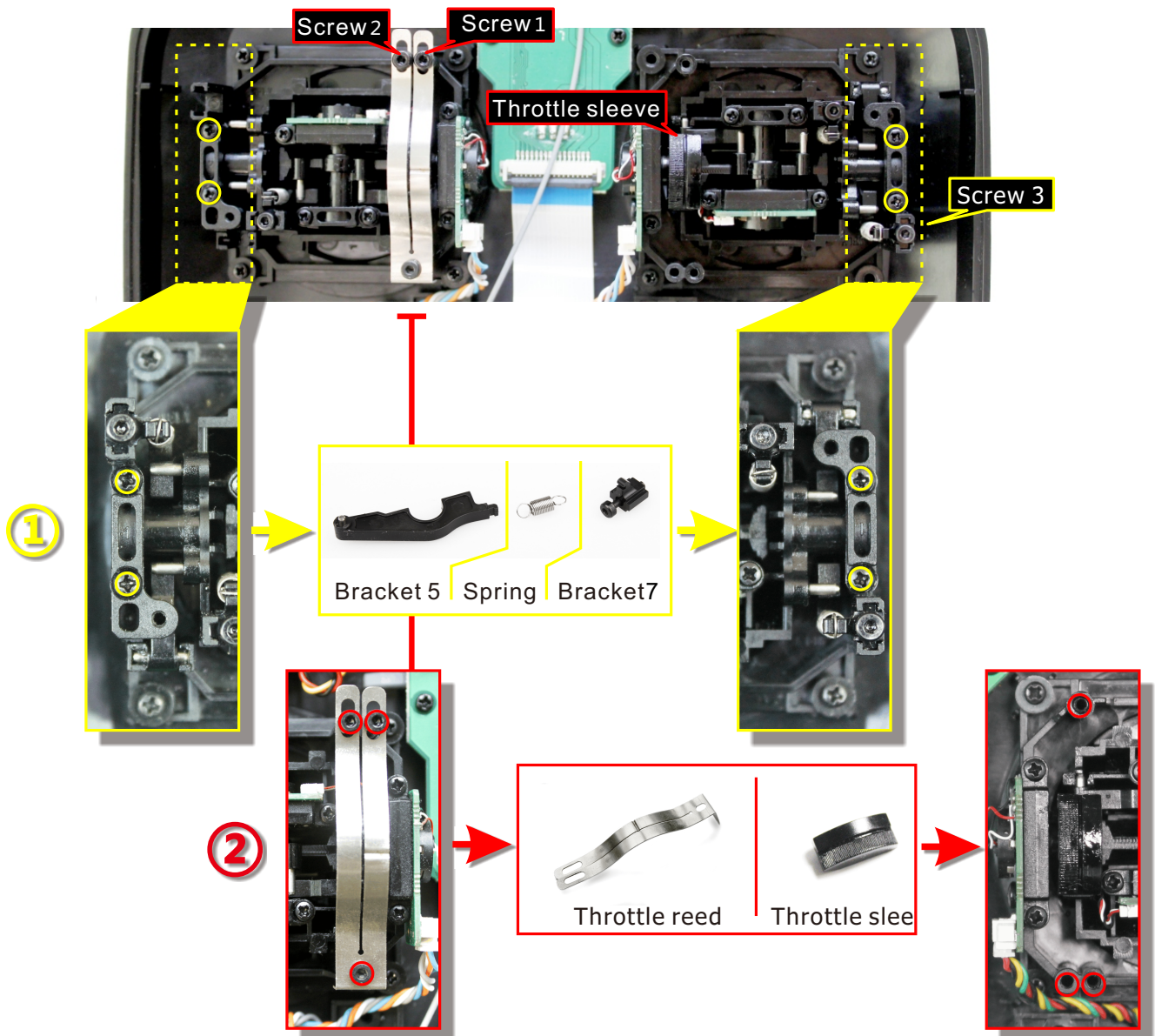

After the throttle structure is modified, turn on the machine, enter [system setting] → [stick mode], select the corresponding operation mode, and then adjust the stick after replacing the left and right modes!

If you need components such as bracket 5 (such as the parts needed for assembling double circuit structure!), you can e-mail to WFLY overseas seller to order the spare parts at [sales@wflysz.com](mailto:sales@wflysz.com)

## Receiver Instructions

### Receiver LED STATUS LIST

Mode	LED	Action	State
Work	Green	Never	W.BUS normal work mode
	Blue	Never	PWM normal work mode
	Red	Never	No signal
	Red	Slow flash	Low voltage
	Orange	Slow flash	Linking
Set	Green	Slow flash	W.BUS mode
	Blue	Slow flash	PPM mode

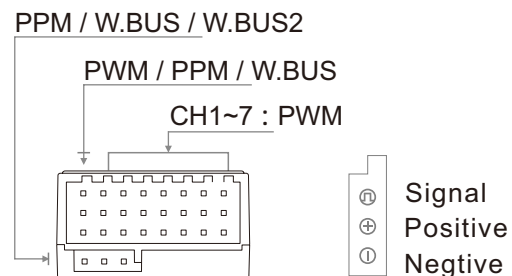

### Receiver Operation Way

1 Link: Charge the receiver then press and hold 'SET' button for 3 seconds, wait for the link instruction after the orange light slowly flashes.

2 PM/W.BUS/PWM port modes select: Click and hold the "SET" to charge, then enter into model setting, slightly click the switcher mode, press and hold to confirm.

### Receiver connection and installation

Notice: pay attention to the positive and negative polarity when connecting the power supply. Do not use the power supply that exceeds the working voltage of the receiver. Otherwise, the receiver will be damaged!

The RF209S is the latest series of high performance receiver with 9 PWM channels, 1 PPM/W.BUS channel (User defined), and 1 W.BUS2 channel (User defined).

In order to obtain optimal signal retrieval performance, the two antennas are preferably processed 90° to each other when installed, as shown in the bottom right diagram.

Notice:

1. If there is a metal conductor around the receiver antenna, the signal performance would be affected. In this case, the antenna should be bypassed by the conductor, placed on both sides of the fuselage, and it is better to make the antenna leak outside the model casing! In this way, good signal reception can be maintained regardless of the flight attitude.

2. When the antenna is installed. The unshielded end of the antenna should be as far away as possible from the conductor materials such as metal and carbon fiber. The antenna cable avoids bending at large angles. And the end core should be as straight as possible.

3. If the model body is covered with a conductive material such as carbon fiber or metal, the antenna portion must be extended beyond the body. At the same time, do not stick too close to the conductive

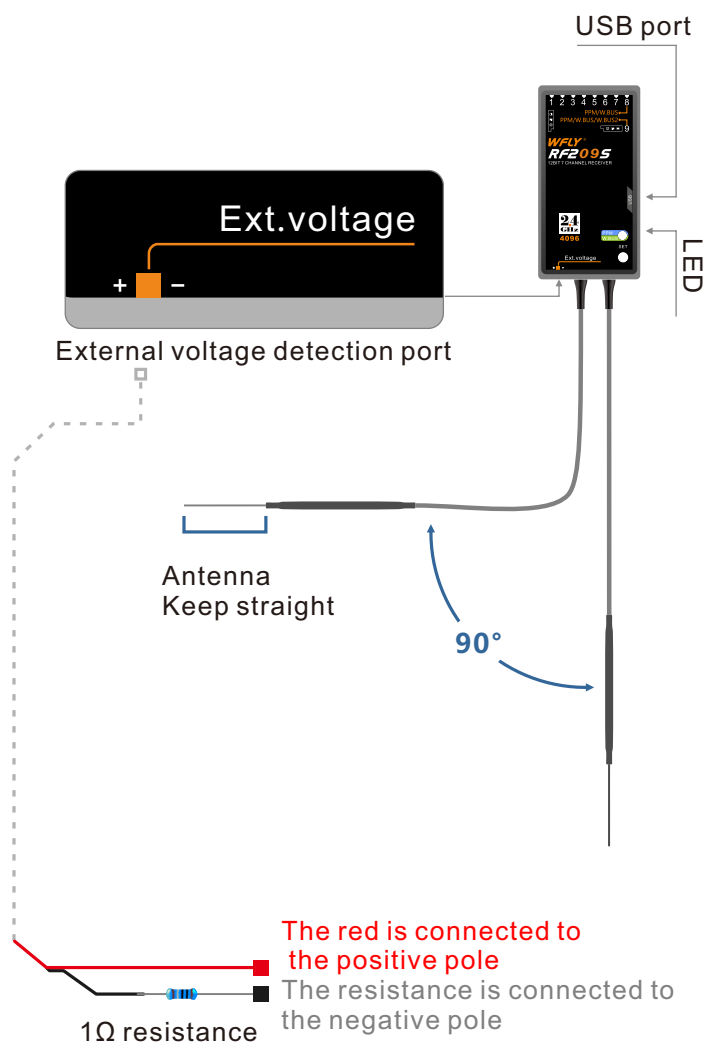

body after the antenna is extended. In addition, the antenna should also be kept away from the fuel tank.



## Receiver and servo Link example

### - Airplane

The figure below shows an example of airplane Link. Please use the actual wing type and tail type for servo Link.

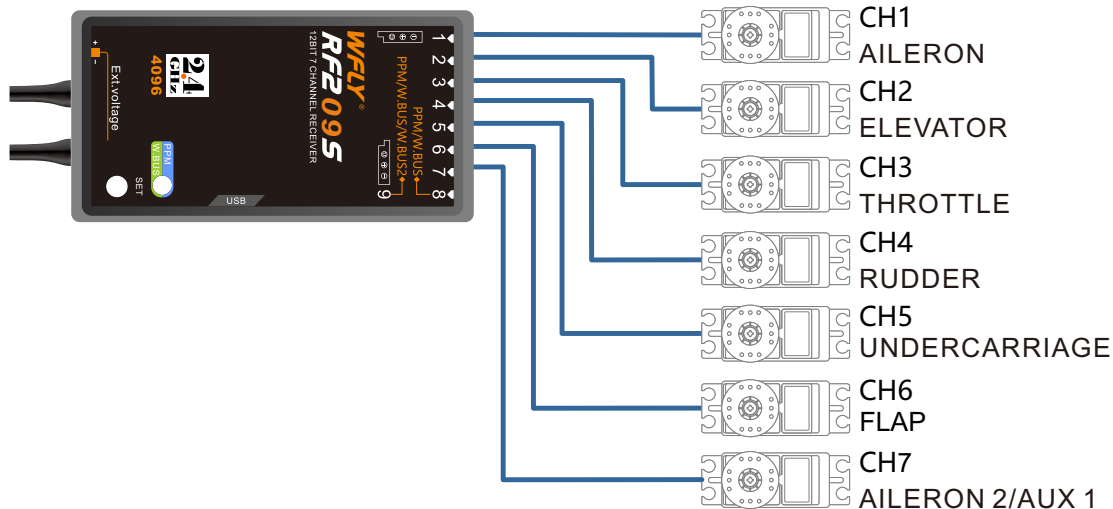

### Servo connection position (Airplane)

The table below shows examples of the servo connection positions for the different wing types and tail types.

Receiver output channel	Airplane(ACRO)	
1	Aileron/Aileron1(*1)1Aileron1(Aileron2)(*2)/Aileron1(Elevator2)(*3)	
2	Elevator/Elevator1(Aileron2)(*3)/Elevator1(Rudder2)(*4)	
3	Throttle	
4	Rudder/Rudder1(Elevator2)(*4)	(*1)When it's AIL Differential (*2)When it's Flaperon (*3)When it's Ailvator (*4)When it's V-Tail
5	Spare/undercarriage	
6	Spare/Flap/Flap1(Aileron 2)(*2)	
7	Spare/Aileron2(*1)	

### Wing

ACRO(Flaperon)(\*2)

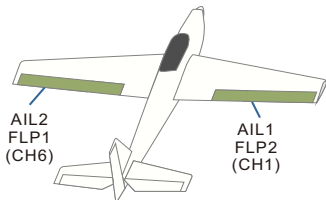

ACRO(AIL Differential)(\*1)

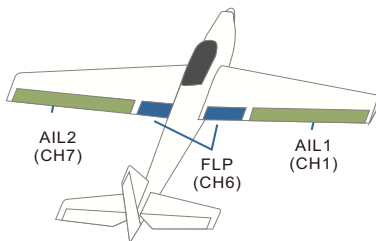

ACRO(Ailvator)(\*3)

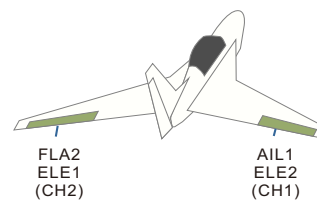

### Tail

(Normal)

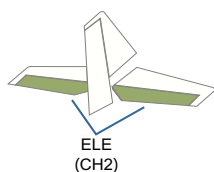

(V-Tail)(\*4)

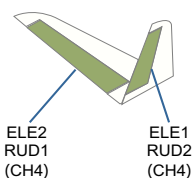

(Ailvator)

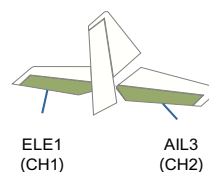



**Receiver and servo Link example**

**-Glider**

The table below shows examples of the servo link positions for the different wing types and tail types.

CH	1AIL(A-1)	2AIL(A-2)	2A+1F(AF1)	2A+2F(AF2)
1	Aileron	Aileron	Aileron	Aileron
2	Elevator	Elevator	Elevator	Elevator
3	Motor	Motor	Motor	Motor
4	Rudder	Rudder	Rudder	Rudder
5	Auxiliary	Auxiliary	Flap	Flap
6	Auxiliary	Auxiliary	Auxiliary	Flap 2
7	Auxiliary	Aileron2	Aileron2	Aileron2

**Wing**

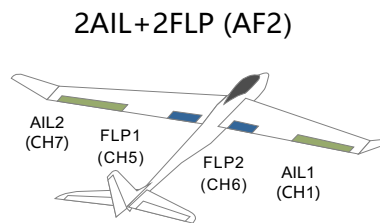
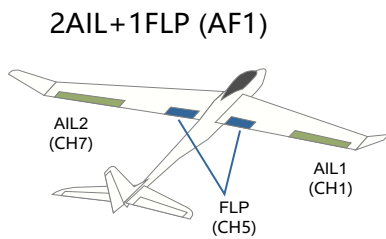
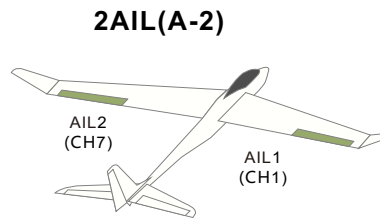
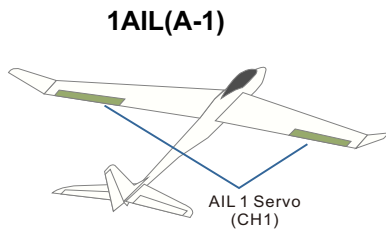

**Tail**

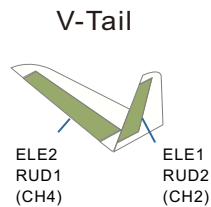
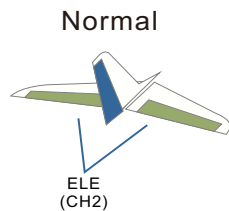



## Receiver and servo link example

### -Helicopter

The figure below shows an example of helicopter link. Please use the actual wing type and tail type for servo link.

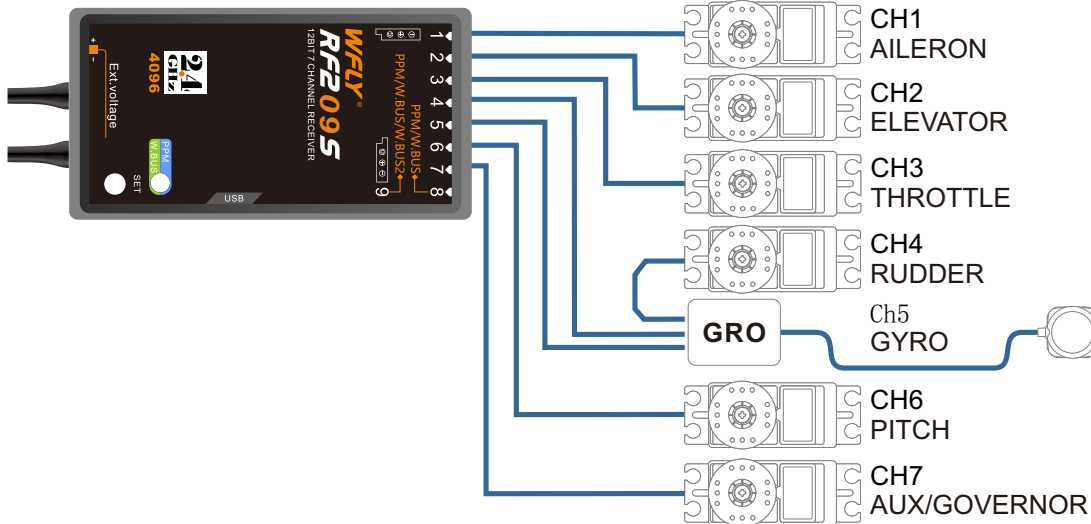

### Servo link position (Helicopter)

The table below shows examples of the servo link positions for different swashes.

Receiver output channel	HELI
1	Aileron
2	Elevator
3	Throttle
4	Rudder
5	Gyro
6	Pitch
7	AUX/Governor

### Swash Types

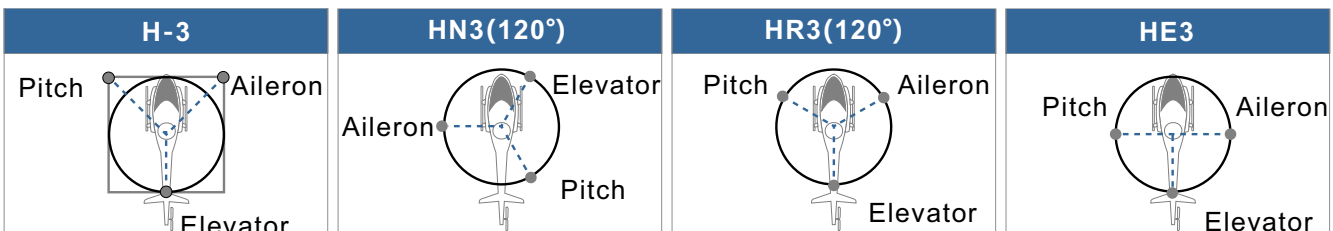



## Receiver and servo Link example

### -Multicopter

The figure below shows the four-rotor multicopter. Please refer to the model manual for specific applications. Motor, electronic speed controller, flight controller, battery, etc. are sold separately.

Use 5CH-9CH when using accessories such as camera shutters. Use a W.BUS interface or dual receiver when the channel is insufficient.

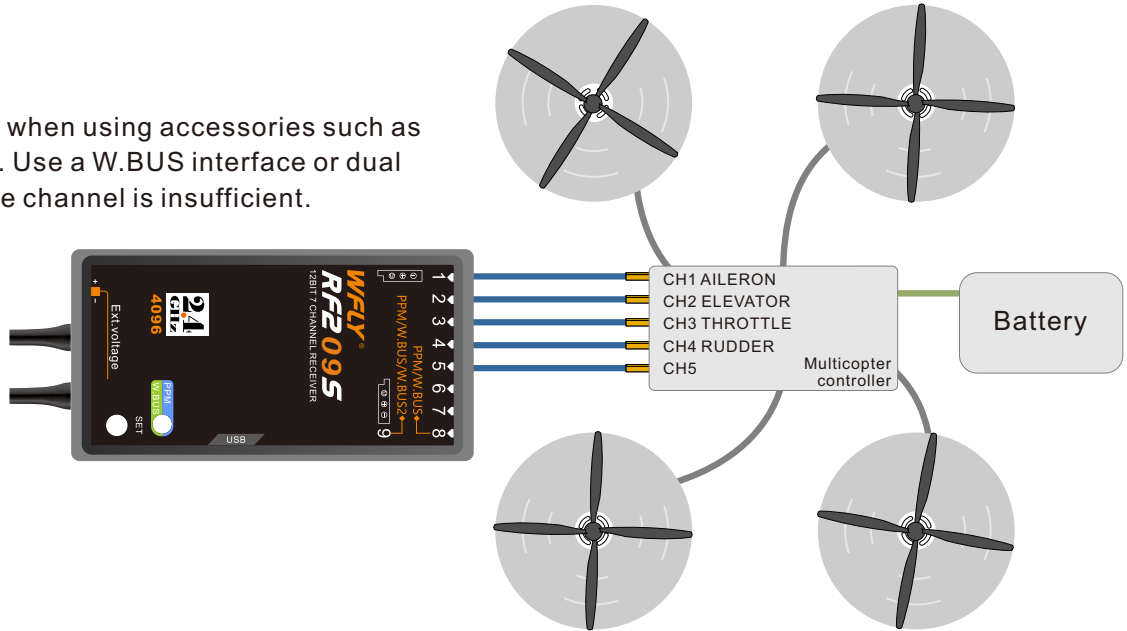

\*This figure is for illustrative purposes only. Link amplification also changes depending on the multicopter collective and the flight controller. Please connect according to the instruction manual of the multicopter kit to be used.

\*Motor, electronic speed controller(separately to buy ).

### Link Position(Multicopter)

Receiver output channel	MULTI COPTER
1	Aileron
2	Elevator
3	Throttle
4	Rudder
5	Spare
6	Spare
7	Spare



## Basic setting sequence of airplane and glider

Taking a conventional F3A as an example, the steps of setting an airplane will be described. In the actual setup process, set the appropriate value according to the subject you want to use. Before setting, select a model that is not set in the model selection function. Then, use the model naming feature to register the name for the model to facilitate later recall operations. In addition, in the [Model Type] function interface, confirm whether the "Airplane and Glider" option has been selected. If you choose another type, you will need to change to "Airplane and Glider".

### 1. Basic end point setting

Before setting the end point, please confirm whether the direction of each rudder surface is correct. If there is any direction that does not match the actual operation, please use the [Servo Reverse] function to change the direction.

The aileron of the wing are set such that the left wing is connected to the receiver 1CH (Aileron) and the right wing is connected to the 6CH. Turn on the [Flaperon] function to confirm the aileron's movement.

The aileron uses the outermost side of the 6-angle rocker arm (B-type rocker arm), the elevator, and the rudder also uses the outermost side. Trim is adjusted through the transmitter[Sub-Trim].

#### ●End point adjustment

The [End Point] setting is performed by the [End Point] function.

**Aileron setting:** The left and right aileron movements generally ensure that the aileron can move up and down from the root to a range of 14 to 15 mm. If you need to adjust. It can be adjusted in the range of 90~110%.

**Elevator setting:** After adjustment, the upper and lower movements are also about 15 mm.

**Rudder setting:** After adjustment, the left and right motion range is about 45°

#### ● [Dual Rate] adjust

The rate adjustment after flight is performed by the [Dual Rate] function.

Initially adjust to the following values.

**Aileron setting:** adjust the ratio so that the upper and lower movements are around 11 mm. Also adjust the EXP function. The EXP ratio input is -20~-30%.

**Elevator Setting :** Adjust the rate so that the upper side movement amount is 12 mm and the lower side movement amount is 13 mm. The EXP rate is set to -15~-20%.

**Rudder setting:** adjust to make the left and right movements 40~45°. EXP is set to about -20%

### 2. Air Brake Setting

Both ailerons are open upwards and used as air brakes. If the nose is raised at this time, please operate the elevator slightly downwards. It can increase the resistance, increase the angle of decline, and the speed won't be lose control, suitable for a relatively small flight space.

Notice: When the crosswind is strong, air brakes are not recommended.

#### ●[Air Brake] Setting

Call up the [Air Brake] menu in [Model Menu].

Control mode Adjust to manual mode. (Normally using manual mode.)

The initial setting switch is SC and the down is on.

The flap rate is set to (Aileron 1/1CH, flap/6CH) +50~+55%, and the elevator rate is set to -15~-20%. Then turn the SC to the down side to confirm the action.

It can be used for medium and slow flight, and then adjust the elevator rate according to the flight status to keep the body in a horizontal position.



## Basic setting sequence of helicopter

Here, a conventional helicopter is taken as an example to explain the setting sequence steps of the helicopter. In the actual setting process, set the appropriate value according to the body to be used.

First, before setting, please select an unset model in the [Model Type] function. Then, use the model naming function to register a name for the model to facilitate later call-out operations.

In the [Model Type] function, confirm whether the "Helicopter" option has been selected. If you choose another type at this time, you need to change to "Helicopter". (The default is HR3 (120°), please refer to the actual

The type of body swashplate used is changed. )

### 1. Connection installation on the machine body

Please install the servos of the ailerons, elevators, throttles, rudders and pitches on the body according to the manual.

If you find that there is a reverse direction after connecting, use the [Servo Reverse] function to change the direction of motion. The direction of operation of the gyroscope should also be confirmed.

The throttle is connected so that the carburetor can be completely shut down by trim and the engine is turned off.

In principle, the rudder angle is adjusted by the steering arm of the steering gear, and then adjusted by the rudder angle adjustment function [End Point].

### 2. Normal / Idle1 / Idle2 / Throttle hold switcher switch

Call the [Fly Mode] function menu or [Throttle hold] under the Model Menu to set the switcher switch to the active state.

(The initial setting is inhibited)

Normal: The action when the switch is off.

Idle1: The action when the switch is in the center position. (third position switch)

Idle2: The action when the switch is switched.

(There is no Idle1 in the two-position switch.)

Throttle lock: Action when the switch is switched.

The order of precedence is: Throttle hold / Idle2 / Idle1 / Normal

Throttle hold is a top priority. (The Throttle hold must be opened during function debugging to prevent the throttle from suddenly starting to cause danger!)

Normal: Used when the engine starts to hover.

Idle1: Use when flying in the air, etc.

Idle2: Use during air roll and other operations.

### 3. Normal setting

Firstly, normal setting. Turn off Idle to normal status.

#### ● Throttle curve

Call up throttle curve menu, select "Advanced"

Throttle curve initial setting is according to the

below figure value.

This setting is a curve set before and after the

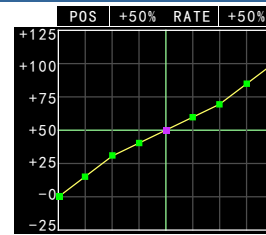

hover (point 5), and is relatively dull near the hover point. Observe the reaction speed and number of revolutions during hovering and adjust 3 to 7 points. Also consider adjusting the relationship with the pitch.

#### ● Pitch Curve

Bring up the [Pitch Curve] menu and select Advanced.

The pitch curve is initially set according to the values in the table below. The pitch when hovering is about +5~+6°.

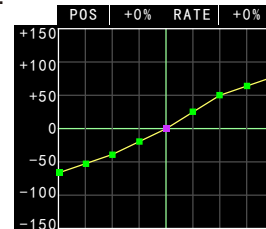

This setting is faster when the stick is in the low position and slower when the position is high.

[Adjustment point 1]

■ Use the left curve point (points 1, 2, 3, 4)

when taking off and landing, and match the rate of ascending and descending.

[Adjustment point 2]

■ Hover sets the pitch rotation number based on the intermediate point (point 5).

■ The setting at the time of rising can change the reaction speed by increasing or decreasing the value of the curve point (points 6, 7, 8) on the right side. (The higher the value, the more sensitive the reaction, the smaller the value, the slower the reaction.)

■ The setting at the time of the drop can change the reaction speed by increasing or decreasing the value of points 2, 3, and 4.

(The larger the value, the slower the reaction, the smaller the value, the more sensitive the reaction.)

### 4. Throttle hold setting

Next, set the throttle hold.

Throttle hold is used to cut the landing action.

When the throttle hold switch is in the down position (Enable the function), it is the throttle hold status.

#### ● Throttle Hold

Bring up the [Throttle Hold] interface.

Set the "Status" item from "INH" to "On/Off".

The servo position while throttle hold is set to 15% (into the idle down status).



●Pitch Curve

From the menu, call the [Pitch Curve] interface and select the "Advanced" curve.

When landing, the maximum pitch is used for both the high and low positions.

The climb status when the pitch rises can be changed by adjusting the points 2~8.

[Pitch angle setting example]

Normal :-2.5°~4.5°~10°

Idle 1 :-2.5°~5.5°~8(10)°

Idle 2 :-3°~5.5°~8(10)°

Throttle hold: -4°~4.5°~12°

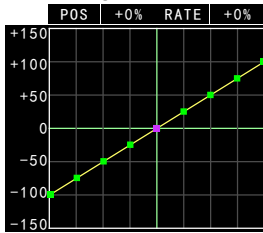

5. Idle 1 setting

Set and activate the "Throttle Hold" function in advance, and set the control switch (here set to SC) in [Fly Mode], and then set the Idle1. Idle 1 is generally used for tendons, stalls, stalls, and stalls. When the Idle switch (SC switch) is in the middle position, it is the Idle 1 status.

●Throttle Curve

Bring up the [Throttle Curve] menu and set the curve to Advanced.

The values are set according to the below table.

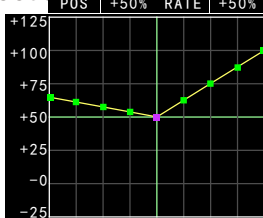

This curve ensures that the throttle stick is placed in the low position and The engine still works with idle speed.

●Pitch Curve

Bring up the [Pitch Curve] menu and set the curve to Advanced.

The values are set according to the below table.

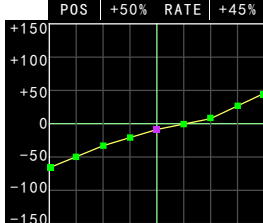

The points 1, 2, 3, and 4 of the pitch curve of the Idle 1 are basically the same as the normal set values, and the hover setting is different: the power of the engine (motor) is different at the high position, and the maximum pitch angle is 8~10°

6. Setting Idle 2

Next, set the "Idle 2".

Idle 2 is mostly used for scrolling.

The Idle 2 status is when the Idle switch is in the down position.

● Throttle curve

Bring up the [Throttle Curve] menu and set the curve to Advanced.

The values are set according to the table below.

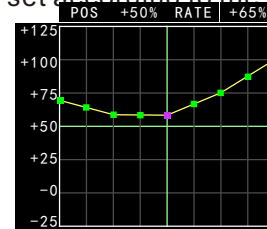

This curve ensures that the throttle stick is placed in the low position and still maintains the amount of idling increase in rotation.

●Pitch Curve

Bring up the [Pitch Curve] menu and set the curve to Advanced.

The values are set according to the below table

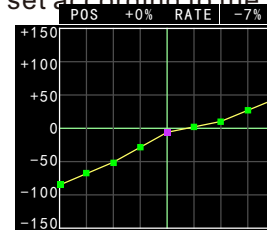

The setting of the high pitch is the same as the setting of the Idle 1 ,The curve is set as shown in the figure.

Now, the pitch setting can make the body climb well in the rolling motion.

7. Gyro sensitivity switching

To change the gyroscope sensitivity, use a gyro sensor to switch the sensitivity.

Gyro sensitivity is high: normal (hover)

Gyro sensitivity is low: Idle 1 / Idle 2 / Throttle hold

However, when landing, the helicopter is driven by the tail rotor. At this time, using the high sensitivity in the holding state of the throttle sometimes has a better effect.

8. Throttle cut setting

The engine cut at the end of the flight can be done without a fine tuning of the throttle but by a dedicated switch.

Since the switch is used, there is no need to find the trimming position. Therefore, the idle position must be kept constant

● Throttle Cut

Bring up the throttle cut menu.

Set the function to the working status.

The offset of the throttle cut is adjusted in the "+" direction to fully close the vaporizer.

As of this point, this part of the setting will come to an end. Finally, the runaway protection function (F/S) is set in the throttle channel. Usually, it is set at a position slightly lower than the hovering position.



### Model Select

The ET10 can store up to 20 groups of model data, which is used to load the saved model data.

Notice:

In [Model Select], the active item is displayed on a green background, and the focused model is displayed on a white background.

Enter the interface:

Method 1: **WFLY** → System Setting → Model Select

Method 2: Click on the model name in the standby interface → Model Select

Setting method:

Press the key - select the desired model name, press the confirm key the prompt box will pop up ("No" is selected by default), select "Yes" to select the effect, and select "No" to cancel the operation.

Touch screen - Click on the desired model name, a prompt box will pop up ("No" is selected by default), select "Yes" to select the effect, and select "No" to cancel the operation.

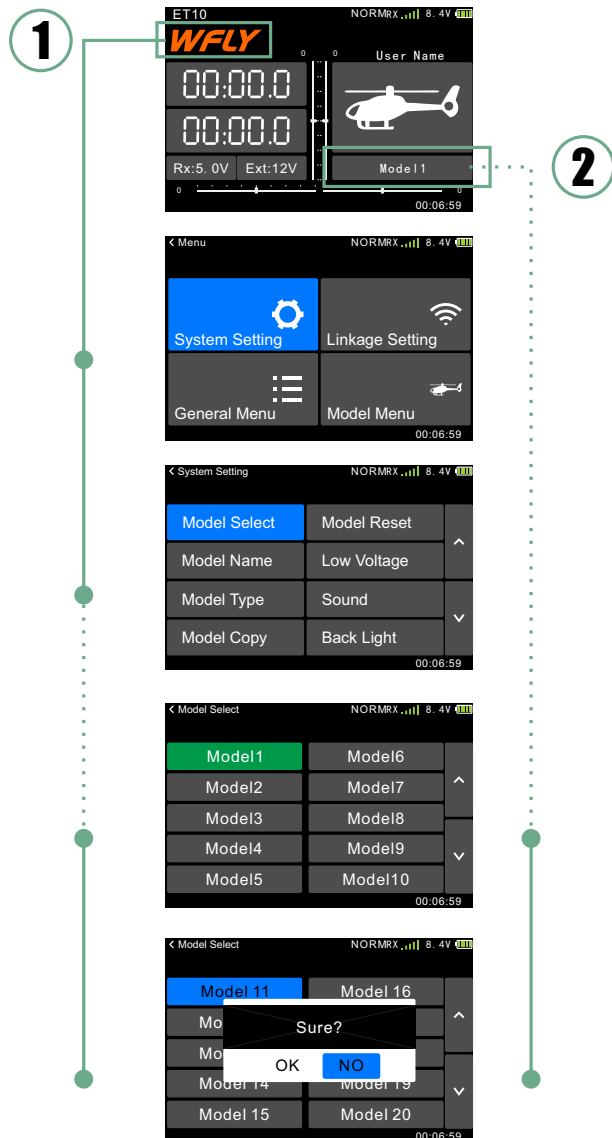

### Model Name

The model names stored in ET10 can be changed. The currently selected model name will always be displayed on the standby screen. This makes it easy for us to distinguish between different model settings and to prevent incorrect calls to other stored information. The name of each model consists of up to 9 characters.

Enter the interface: **WFLY** → System Setting → Model Name

Notice: The model name length supports 9 characters. The keyboard interface can only be operated by touch screen. To save and modify, just click the [OK] button, click the [EXIT] button and the [Back] button to cancel the change to the return list. Click the "function name" in the upper left corner to exit to the previous menu List

Setting method:

1 Enter and exit the model name change interface (keyboard):

Click the key - Toggle the arrow keys to select the option to change the name.

Press the ENTER button to bring up the name and keyboard, and press the left button to return to the model name list.

Touch Screen - Click the model name option to be changed in the model name list to pop up the name and keyboard. Click the [EXIT] button in the lower left corner to cancel the change of the model name and return to the model name list.

2 Name modification

The use of the keyboard: [←] key is the delete key, [↑] key is the size letter and symbol switch key, [EXIT] key is the return key, [OK] button is OK to save button

Tip: If the name does not have 9 characters, select any character to insert or delete characters in front of it.

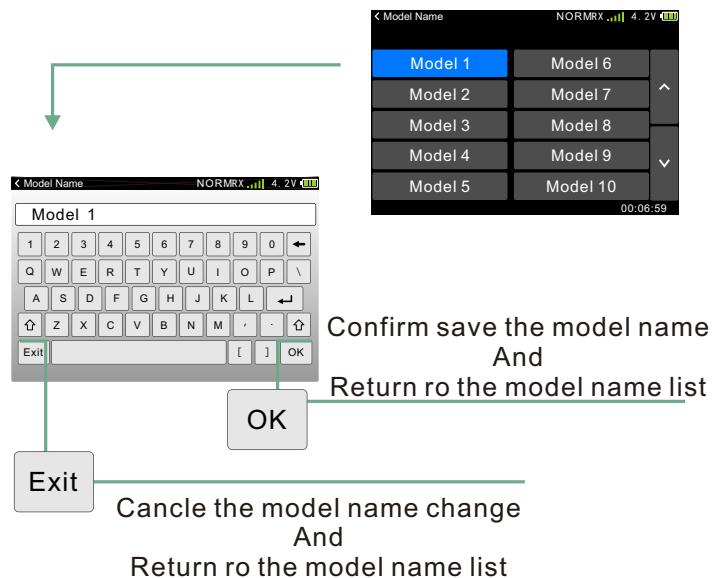



### Model Type

Depending on the type of the model aircraft used, choose among the following model types. There are three options for helicopter, airplane and glider, multicopter in the transmitter. The list in the model function will also change according to the selected model.



Note: After selecting the model type, the transmitter selected model type is automatically restored to the initial setting. When you select the model [Model Type] operation, all its parameters have been reset, so if you are changing the model type Also want to save the original settings, please use the [Model Copy] function to back up the model data in advance.

Press the key - select the "Model Type" key, press the confirm key or the plus or minus key to switch the model (the model you are using is displayed in green background); after selecting the model, toggle the direction button Switch to the "Confirm" button and press the enter key, the prompt box will pop up, select "OK" to select the effect, select "No" to cancel the operation.

Touch screen - Click the "model" button to switch the model, click the "Confirm" button, a prompt box will pop up, select "OK" to select the effect, select "No" to cancel the operation.

Enter the interface: **WFLY** → System Setting → Model Type

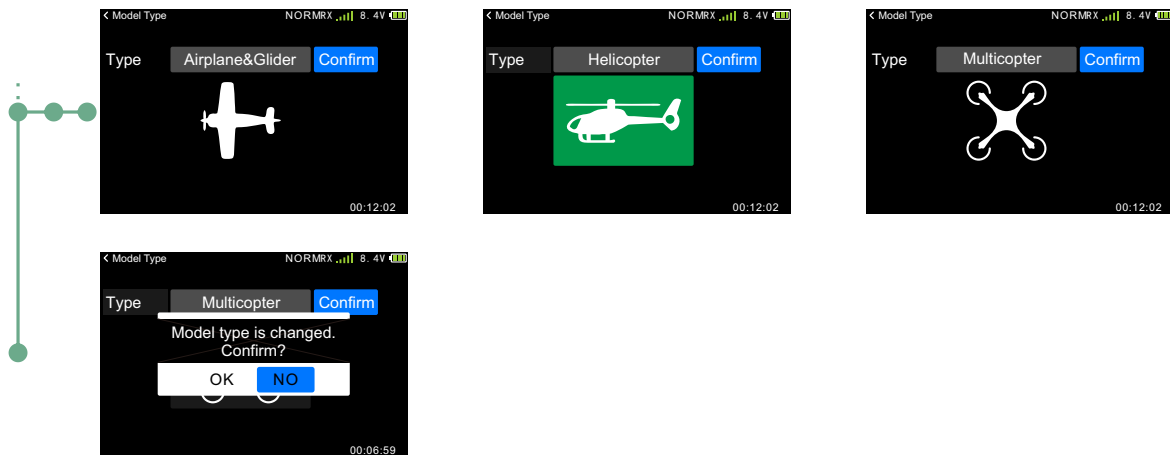



### Model Copy

[Model Copy] can be designed to facilitate model data editing and data backup of the same type and small difference. With this function, you can quickly and safely do new model parameters when you add new model data without having to reset all the parameters. At the same time, this function can also be used as a function of data backup.

**Notice:**

As shown in the example, the model on the left is the source data model, and the model on the right is the target model that is covered. Therefore, when selecting the model on the right option, be careful not to overwrite the model you wish to keep.

**Enter the interface: WFLY → System Setting → Model Copy**

**Setting method:**

Click the key - Toggle the arrow keys to switch between the source model, the target model, and the copy operation key. When the model option is selected, press the enter key or the plus or minus key to switch the model group; when the "Copy" button is selected, a prompt box will pop up ("No" is selected by default), select "OK" to select the effect, and select "No". Cancel the operation.

Touch screen - Click the model name to switch the model selection. After selecting the source model and the target model, click the "Copy" button to pop up the prompt box. Select "OK" to select the effect. Select "No" to cancel operating

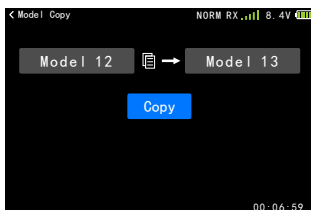

### Model Reset

The model reset function resets the currently selected model data to the initial set value.

Note: The parameters of the selected model will be reset.

**Enter the interface: WFLY → System Setting → Model Reset**

**Setting method:**

Press the key - select the desired model name and press the Enter button. The prompt box will pop up (No is selected by default). If you select "OK", the selection will take effect. If you select No, the operation will be canceled.

Touch screen - Click on the desired model name, a prompt box will pop up, select "OK" to select the effect, and select "No" to cancel the operation.

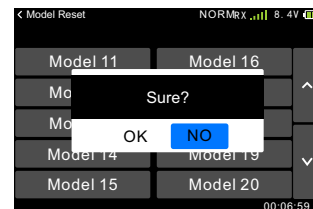



### Low Voltage

Depending on the type of the model aircraft used, choose among the following model types. There are three options for helicopter, Airplane and glider, and multi-rotor in the transmitter. The list in the model function will also change according to the selected model.



**Notice:**

The ET10 has three voltage detection alarms. In addition to the transmitter voltage, the receiver and the receiver's external battery, the two voltage values will only take effect if the "telemetry" function is turned on.

The setting of the low voltage should be set according to the battery capacity, type, old and new battery factors. In order to avoid the loss caused by the low voltage automatic shutdown, please drop the model in a safe situation as soon as possible after the alarm.

**Enter the interface:WFLY → System Setting → Low Voltage**

**Setting method:**

Press the key - select the setting item after pull the arrow key ; press the plus or minus button to adjust the value, press and hold the confirm button to reset the value; press the return key to exit the interface and save the setting.

Touch screen - click on the number you want to set, the "Plus", "Reset", "Reset" buttons will pop up on the right side. Click the function name on the upper left corner to save the setting.

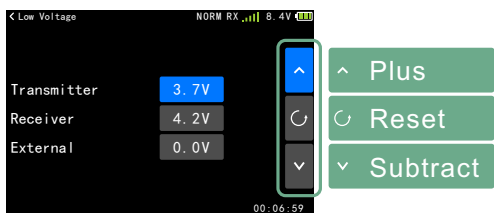

Low Voltage reference value:

1. Transmitter

Lithium battery: 7.4V

2. Receiver

1S Li-Po battery: 3.7V

2S Li-Po battery: 7.4V

ESC (5V) power supply: 4.7V (if high voltage 8.4V power supply, Then set to 7.4V. )

3. External

When using lithium battery:  $S \times 3.7V$  (S is the number of lithium batteries, such as 2S lithium battery, then  $S=2$ . );

For other battery types, please follow the instruction manual of the battery you are using to set.

### Sound

Turns the operation on and off to trigger the sound.

**Note:** This function can only set the prompt sound of the interface operation (button, touch screen operation), does not affect the function prompt (timer), alarm and other sounds!

**Enter the interface:WFLY → System Setting → Sound**

**Setting method:**

Press the key - press the plus or minus key or the confirm key to switch the switch state, press the return key to exit the interface and save.

Touch screen - click the switch key to switch the status, click the function name in the upper left corner to exit the interface and save.



### Backlight

Adjust the brightness of the display backlight to suit different usage environments.

**Note:** The backlight time means that when the button and touch screen operation are not detected, the backlight will automatically decrease after the set value time! The backlight can be set to be bright according to the needs of use!

**Enter the interface:WFLY → System Setting → Backlight**

**Setting method:**

**1 Brightness setting**

Press the button to set the value, press and hold the OK button to reset to 50% brightness. Press the Back button to exit the interface and save.

Touch panel - click or drag the slider to change the brightness, click on the upper left corner Can name the interface and save it.

**2 Backlight time**

Press the key - plus-subtract key to set the value, press and hole the OK key to reset the value.Press the Back button to exit the interface and save.

Touch screen - click to switch the time slot, click on the function name in the upper left corner,exit the interface and save

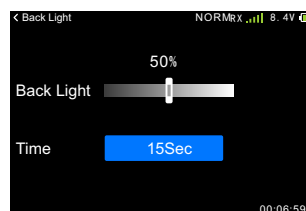



### Trainer/Simulator

Trainer can assist students in learning flight skills and improving flight levels based on their flight experience and operational level. A special trainer line (sold separately) is required between the trainer and the trainer to connect. The trainer must open the trainer mode before the trainer can operate. When the trainer switch is turned off, it will return to the trainer transmitter to control the flight. When the student machine flight is dangerous or the deviation is too large, you can switch immediately to ensure safety.



**Note:**

Be sure to confirm all the channels of the trainer and the student before flying.

Can be controlled normally. Be sure to confirm that the interface of the trainer line is firmly inserted.

Free from looseness. The trainer switch is set to switch SD by default.

**Types:**

Normal, trainer: as the control transmitter;

Simulator: When practicing flight through the computer-side simulator, the RF is turned off, reducing power consumption to extend the transmitter working time;

Student: Turn off the RF transmission right, only the trainer can open the trainer switch to control the turn on channel of the trainer! (Example: The trainer has only three channels of aileron, direction, and gyroscope open, then the student can only control these three channels if the trainer plays the trainer switch.)

**Mode:**

The default is "8 channel" setting, compatible with the world's "WFT" series

Product trainer function. The trainer's two ET10s need to set the same mode.

**When WFT08/09 is used as the trainer, please purchase the special analog cable for WFLY and the 3.5mm male to male cable.**

**Steps:**

1 WFT08/09, press and hold the MENU key to turn on → modulation type, set to PPM mode.

Connect the servo to the receiver and connect the servo. Connect the trainer line to boot

2 Settings: ET10 enters the [Trainer/Simulator] menu, the mode is set to "Student", the channel is set to "8 channels", and after a few seconds, the mode detection and switching can be completed.

3 Verification: WFT08/09 toggles the coach switch to position 2 and operates the ET10 related stick or other switch. Check if the servo of the corresponding channel is working normally.

**Enter the interface: WFLY → System Setting → Trailer / Simulator**

**Setting method:**

Press the key - dial arrow key to select the item; press the Enter key/Add/Down key to switch the working mode, switch, and controlled channel switch. The return key exits the interface and saves.

Touch Screen - Click the "Type" key to switch the working mode (Trainer mode: click the corresponding key to toggle the switch or turn the controlled channel on/off). Click the function name in the upper left corner to exit the interface and save.

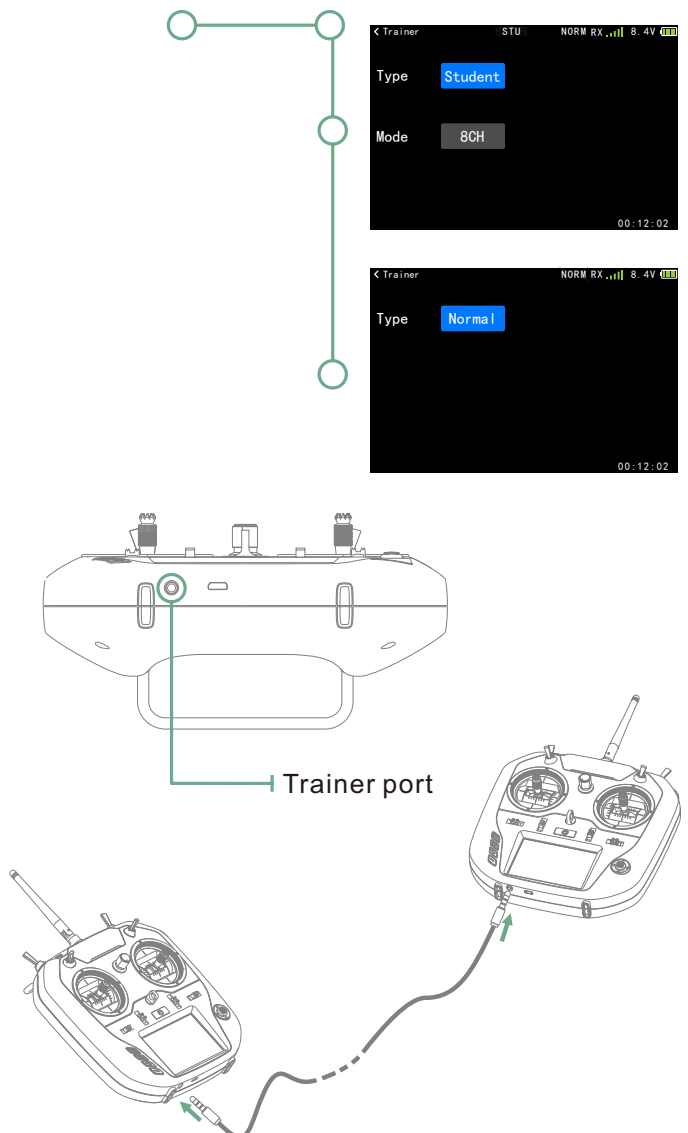
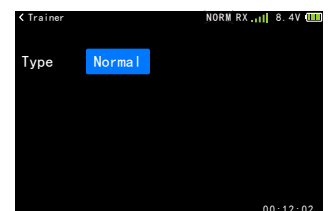
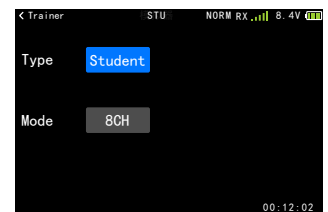



### User Name

The user name is composed of up to 9 characters. It supports English character input and is displayed on the standby interface.

**Notice:** The character editor of this interface can only be operated by touch screen!

**Enter the interface:** WFLY → System Setting → User Name

Setting method:  
For the operation method, please refer to the model naming.

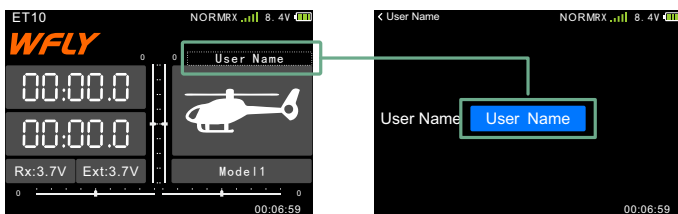

### Back Color

This feature sets the back color and taps the option to change setting.

**Enter the interface:** WFLY → System Setting → Back Color

Setting method:  
Press the button-press the confirm button or the plus or minus button to switch the back colour; press the back button to exit the interface and save it.  
Touch screen - click on the back colour style to switch the color, click on the top left corner function name exits the interface and save.

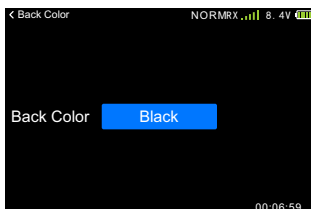

Done

5

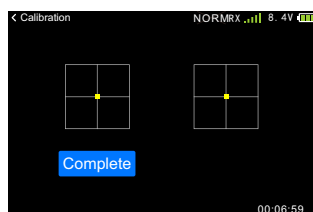

### Calibration

In general, the stick has been calibrated at the factory. If the center position of the stick changes, you need to use this function to calibrate the stick.

**Note:** For calibration, please refer to the scale of the assembly surface for alignment! If the calibration process cancels or exits the function interface, the calibration is invalid!

**Enter the interface:** WFLY → System Setting → Calibration

Setting method:  
Press the key-press the confirmation key to perform the calibration function. According to the yellow point of the operation prompt, perform the corresponding stick operation; press the return key to exit the calibration interface without saving the calibration.

Touch screen-Click the "Start" calibration button, follow the prompts to operate the stick, and finally click "Complete" to save the calibration operation; click the function name in the upper left corner to exit the interface and save.

\* The midpoint calibration of calibration step 4 requires manual confirmation of the position (click the [OK] button).

Start calibration

1

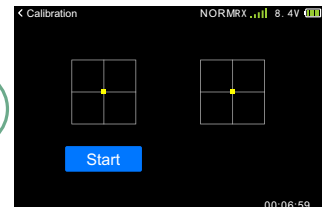

Left & right stick move to the lower right corner

2

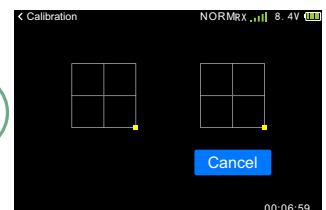

Left & right stick move to the lower left upper corner

3

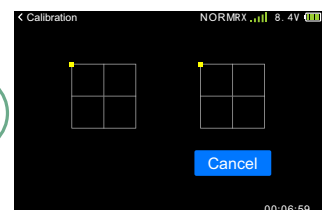

Left & right stick move to the neutral position (click "OK")

4

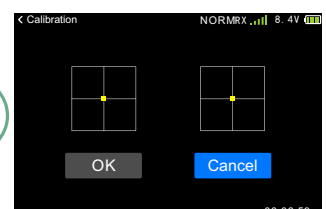



### Stick Mode

Users can choose familiar operating modes according to their own operating habits, and ET10 offers a choice of 4 operating modes.

**Note:** The switch saves immediately for the stick mode function,

**Enter the interface:** WFLY → System Setting → Stick Mode

Setting method:

Key-press the confirm key or the plus /minus key to switch the stick mode; press the return key to exit the interface.

Touch panel - click the "mode" number key to switch mode; click the function name in the upper left corner to exit the interface

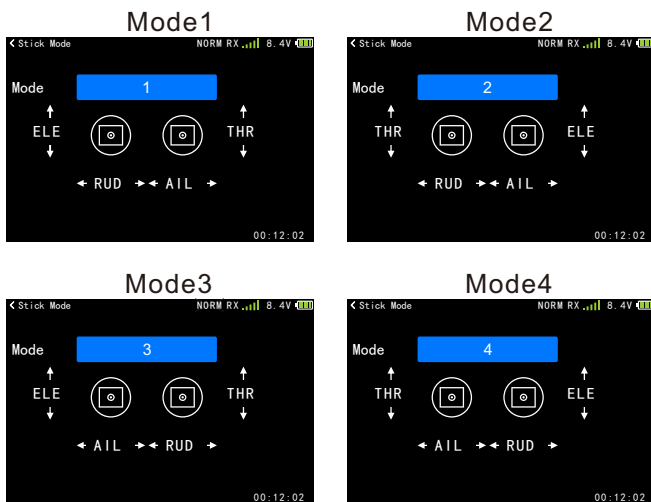

### Factory Reset

Reset all the parameter settings of the transmitter.



**Cautious:** This operation will lose all the exist data!

**Enter the interface:** WFLY → System Setting → Factory Reset

Setting method:

Press the button-press the confirm button to activate the reset function, select whether to reset, "Yes" to reset, "No" to return to the interface; press the Back button to exit the stick mode interface.

Touch screen-Click the "Restore factory setting" button, choose whether to reset, "Yes" to reset, "No" to return to the interface; click the function name in the upper left corner to exit the interface.

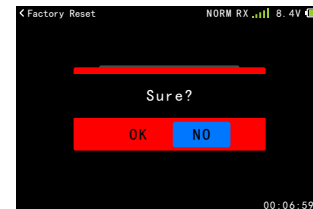

### Telemetry Unit

Set the telemetry display unit

**Enter the interface:** WFLY → System Setting → Telemetry Unit

Setting method:

Press the key- arrow keys to switch between items that need to be replaced. Press the Enter key to switch the unit type. The return key exits the interface and saves.

Touch Screen - Click on the item that needs to be replaced to switch the type. Click the function name in the upper left corner to exit the interface and save.

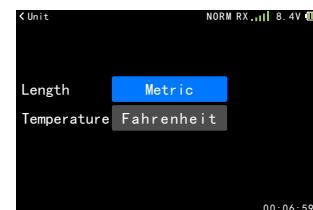

### Language

Select the language displayed on the interface, ET10 provides Chinese or English display.

**Enter the interface:** WFLY → System Setting → Language

Setting method:

Press the button-press the confirm button or the plus or minus button to switch the language (immediately save); press the back button to exit the language selection interface.

Touch screen-click the button to select the language (immediately save); click the function name in the upper left corner to exit the interface





### Screen Cal(Calibration)

Depending on the characteristics of the resistive screen, the corresponding contacts may drift after prolonged use. It is therefore necessary to recalibrate the coordinate position of the touch point of the screen.

Interface path: **WFLY** → **System Setting** → **Screen Cal**

Setting method:

Touch screen-Click the center of the circle according to the prompt circle displayed on the screen; after four clicks, complete the calibration and return to the menu list.

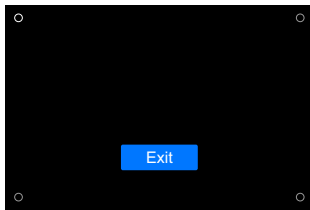

### Information

Show system version information and system upgrade entry.

**Note:** The system upgrade needs to use the computer. Please ensure that the transmitter is fully charged during the upgrade process.

Enter the interface: **WFLY** → **System Setting** → **Information**



### Transmitter Upgrade Step

- 1 Open the computer side upgrade tool
- 2 The transmitter connects to the computer with a USB cable and activates the upgrade status.
- 3 Computer-side upgrade tool display device, click Upgrade.
- 4 Complete the upgrade and unplug the USB!

### Receiver Upgrade Step(Move out the power supply!)

- 1 Open the computer upgrade tool.
- 2 USB connection computer.
- 3 Receiver power off and hold down SET button to connect USB.
- 4 Computer-side upgrade tool display device, click Upgrade.
- 5 Complete the upgrade and unplug the USB!

### System upgrade method:

\*Note: The upgrade operation will not clear the user data. The upgrade process power indicator will flash and the upgrade status will be displayed by the upgrade tool.

\*Drive: If the computer does not recognize the connected device, please use the driver file in the same directory as the upgrade package. (Download the upgrade package at en.wflysz.com)

If you have any questions, please contact WFLY after-sales customer service consultation : service@wflysz.com

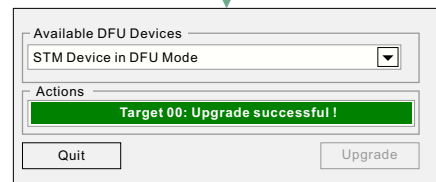
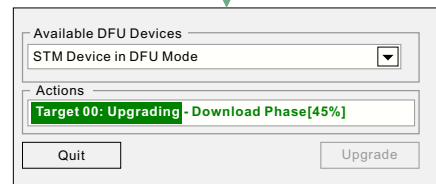
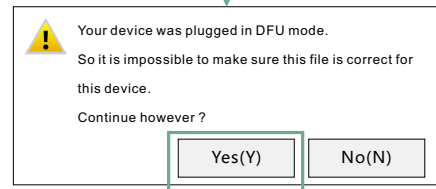
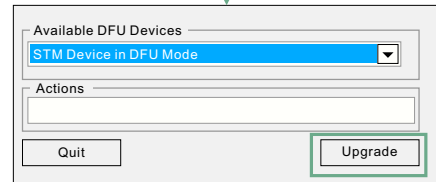
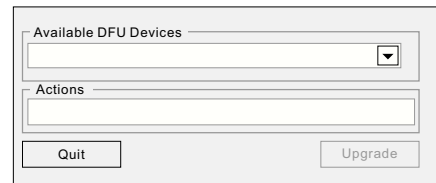



## Screen Lock

When the transmitter operates the device in the field, the user needs to use the lock screen function according to the actual needs. In order to prevent accidental touch, the screen can be locked

Enter the interface:  
Click **WFLY** on the standby interface → System setting → Screen lock

Setting method:  
Button -- Press the five-way arrow key to select the focus area "Screen lock";

Press the five-way confirmation key to switch between "Screen Lock" and "Advanced Lock".

Touch screen -- Click "Focus area", toggle "Screen Lock", "Advanced Lock".

### 1. Screen Lock:

① Lock: Long press EXIT for 2 seconds to lock the touch mode function.

② Unlock: Hold down EXIT for 2 seconds to unlock the screen.

### 2. Advanced lock screen:

① Lock: Long press the "EXIT" button for 2 seconds, locking includes, trim,

HOME menu key, plus and minus keys, five-way key

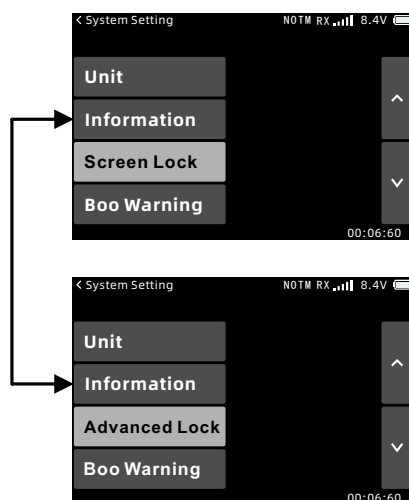

## Boot Warning

The user sets "Startup warning" according to the actual situation to avoid the cause. When the transmitter is powered on, some functions are enabled and users do not pay attention to them, this may cause equipment damage or personal safety.



### Throttle warning Do not disable unless necessary

To enter the interface:  
On the Standby screen, go to **WFLY** → System setting → Startup warning

Setting method:  
Button -- press the five-way arrow key and select "Startup Warning"; Press the minus key select the status, and press the five-way confirmation key to enable/disable. Select switch, knob, throttle, press the five-way confirmation key, read the position, as the boot does not alarm position, long press the five-way confirmation key, disable warning.

Touch screen -- click and select "Startup warning"; Click Status to enable/disable. Click and select "focus area" to read, switch, knob, throttle position, as the startup does not alarm position, long press "focus area" to disable.

### 1. Starting throttle rocker position alarm:

① When the throttle lever is not at the lowest point, the buzzer will alarm until the throttle lever is at the lowest point.

② When a prompt is displayed on the warning screen, press "OK" or swing the accelerator to the lowest position to start the machine.

2. Switch position alarm: the switch position is not in the default position when starting position, the alarm interface will appear (display the corresponding switch), The interface disappears when all switches are in the default gear.

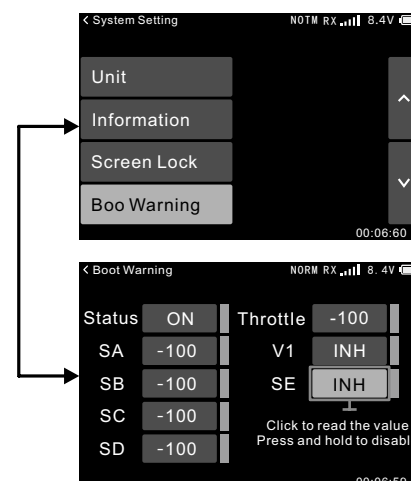



### Link Step

The link function is used for matching the transmitter and receiver.



**Warning:**When linking, please be careful not to connect the power equipment, and remove the propeller, pay attention to safety!

**To ensure safety, please do not link in the status where the motor and engine are running.**

**Note:**

- 1. The transmitter and receiver must be close to each other (less than 1 meter);
- 2. The transmitter cannot perform link operation in the simulator and student mode ([System Setting] → [Trainer] to set);
- 3. There is no other WFLY 2.4GHz system in progress.
- 4. In the process of linking, if you need to exit the link, click the "Cancel" button or press the Back button.
- 5. After finished the link, the connection verification must be performed.
- 6. Telemetry: Disabling this function when link will affect the use of [Range check] [Low battery] [BUS Servo Setting] [Telemetry], etc.

**Interface path:**WFLY→Linkage Setting→Link

Setting method:

- 1. After the receiver enters the link status (the receiver is powered on, press and hold the SET button for 3 seconds, the orange light flashes slowly);
- 2. Transmitter, click the "Start" button to enter the link status (RF light flashes slowly);
- 3. After link successfully, the transmitter RF light is always on, the receiver green light is always on (default W.BUS mode), or the blue light is always on (PPM mode).

Verification: connect the servo, operate the transmitter, and the corresponding servo has the synchronous action output, that is link successful;

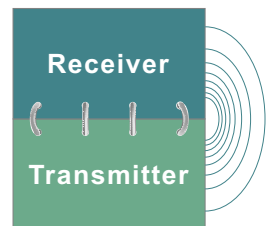
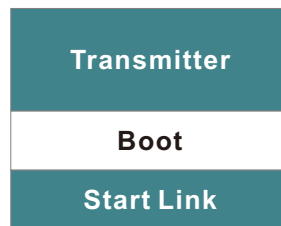

The selection of the working mode (default working mode A) uses the default value when using channels with less than seven channels. When using more than seven channels (using two receivers), refer to the following list for link setting.

Output Slot	Preset channel	
	Model A	Model B
1	1	5
2	2	6
3	3	3
4	4	7
5	5	8
6	6	9
7	7	10
8	W.BUS/PPM	W.BUS/PPM
W.BUS2	W.BUS2	W.BUS2

\*Receiver firmary: V1.1.04



## Telemetry

The telemetry interface displays the collected telemetry data.

**Note:**

Inhibiting "Telemetry" when link will affect the use of [Range Check] [Low Battery] [W.BUS Servo] [Telemetry].

**Shutdown protection system:**

When the "telemetry" function is enabled, the transmitting machine automatically detects whether the receiver is working. If it is still in the working state, the transmitter needs to be confirmed before it can be shut down normally! Avoid the transmitter shutdown and cause the receiver to enter the fail safe state, thus avoiding accidental damage and loss of personal property caused by the model.

**Interface path:**

Method 1: **WFLY** → **Linkage Setting** → **Telemetry**

Method 2: Click the telemetry information box in the standby interface.

Receiver working voltage  
External battery voltage

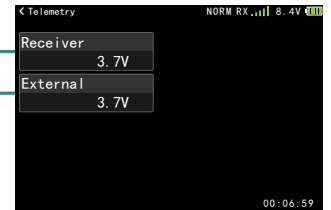

## Servo Frequency

When the servo frequency is used to use the digital servo, adjust the receiver output frequency to match the operating frequency of the servo to better play the servo performance.

Adjust the output frequency of the receiver, the range is 50Hz~400Hz, and the setting is successful when exiting.

**Note:**

Please do not change the servo frequency parameters easily. Otherwise there is the possibility of damage to the servo!

This function requires the transmitter and receiver to be in normal linkage state, and the setting can be effective!

**Enter the interface:** **WFLY** → **Linkage Setting** → **Servo Frequency**

**Setting method:**

Press the button-press the confirmation button to call up the parameter adjustment button, the up/down direction button to switch the button, and press the enter button to adjust the parameter. The Back button exits the interface and saves the settings.

Touch Screen - Click on the value and click the Add, Subtract, Reset button on the right to edit the value. Click on the function name in the upper left corner to exit the interface and save the settings.

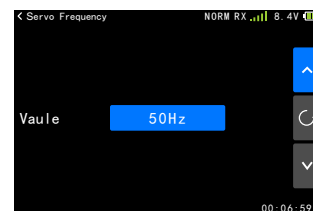



### Range Check

The range check is mainly used to test the distance.

**Note:** Turn on the telemetry when linking. After linked, the transmitter receiver can be connected normally to use this function! Only enter this interface, after toggling the SH switch, the power will be reduced! The control distance is related to the actual use environment!

**Interface path:**

**WFLY** → Linkage Setting → Range Check

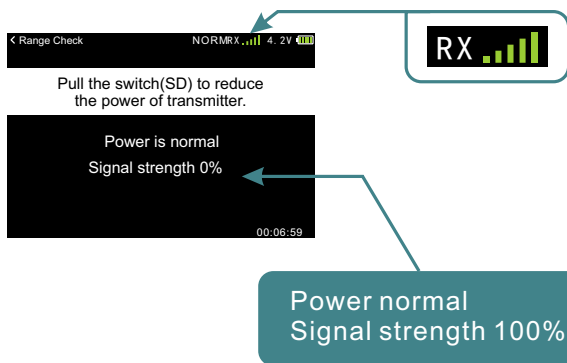

**Instructions:**

1. Enter the interface and toggle the SD switch.
2. The transmitter and receiver maintain a certain height (about 1.5 meters) and the antennas are in the same direction (perpendicular to the ground).
3. The transmitter and receiver are powered, start moving position, move the stick,
4. The transmitter to view the signal strength of the "RX" in the upper right corner of the screen (The receiver receives the strength of the transmitter signal) and the receiver checks to see if the status light and servo are moving smoothly. This comprehensive evaluation of the working distance!

**Signal strength judgment:**

The transmitter signal strength returned by the receiver can be viewed in the upper right corner of the screen status bar (the standby interface during normal operation) and the signal strength percentage indication ([Range Test] function interface). The more indicator bars, the larger the percentage value. The better the signal, conversely, the worse signal. The status bar has no signal bar indication, and there is no signal when the signal strength is 0%.

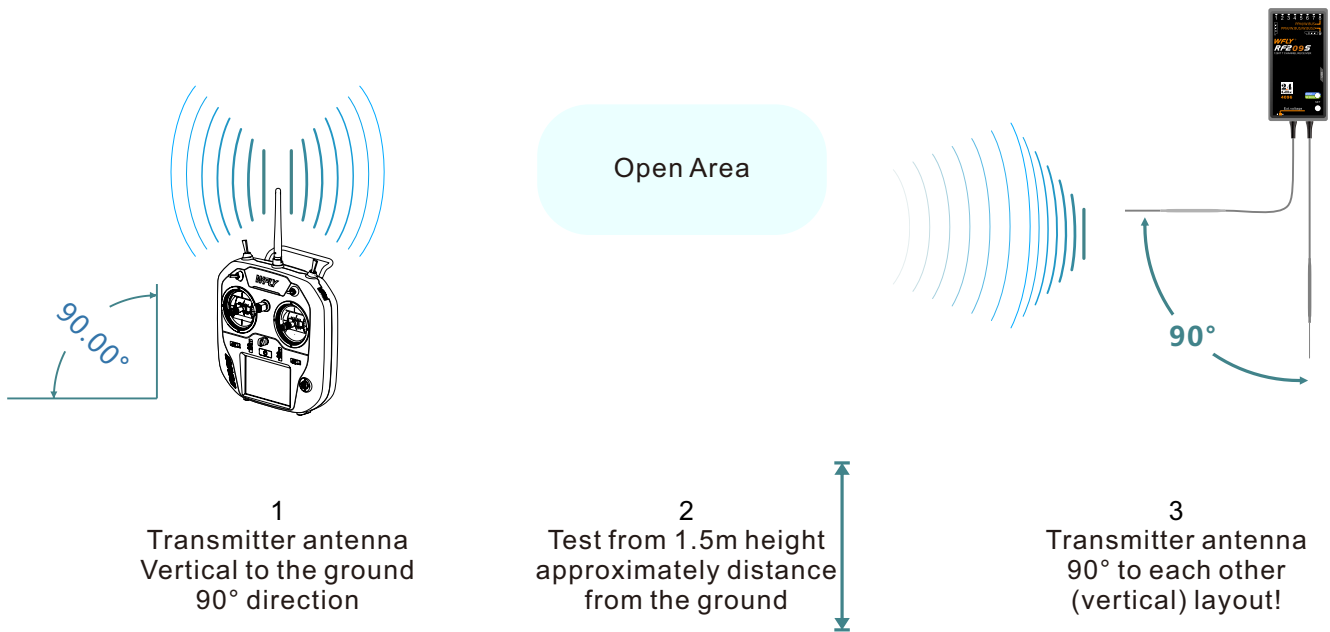

**\*[range Check]The results are for reference only and are not intended as the only performance standard, depending on the specific usage environment!**



## Fail Safe

When the signal encounters radio interference or exceeds the control distance, the fail safe function can set the servo holding position to protect the aircraft and reduce unnecessary losses.

For each channel, three protection modes can be set.

1 Hold: Hold mode, the servos remain unchanged in the last operating position before fail safe. (keep the action).

2 F/S: Fail Safe mode, after the controller is under fail safe, the servo is rotated to the preset position (preset action).

3 Off : Turns off the current channel output. (Only for some special models or some of the flight control board detection ports).



**For your safety, be sure to set up fail safe protection. Especially the Fail Safe of the throttle channel. In that way, the airplane flight speed is reduced and the helicopter is decelerated from the hovering state. It is very dangerous to drop the plane at high speed due to fail safe.**

### Interface path:

**WFLY** → Linkage Setting → Fail Safe

### Setting Method:

Mode--+/-/confirm key switching program working mode(Switching mode:OFF,F/S,Hold).

F/S value: Click the corresponding key to the value or press the confirm key to get the current stick or switch position parameters. (F/S value can only be displayed and set in F/S mode)

**Reference:** Model fail safe is very dangerous, so you should be careful when setting this function, you can refer to the following suggestions, or send an email to [service@wflysz.com](mailto:service@wflysz.com) or add Skype/WeChat/WhatsApp account: +86-189 2382 0083.

Setting reference (only recommended settings, please set according to your actual flight situation):

1. The helicopter throttle is set to the lowest value, and the remaining channels are set to run smoothly.

2. The airplane/glider throttle is set to the lowest or low idle speed, and the other channels are set to run smoothly (or hovering), because the airplane/glider can slide down without power.

3. Please refer to the flight control manual for multicopters.

### Additional protection features:

**The ET10 provides active protection. As long as the telemetry function is turned on, as long as the RF209S receiver is still powered on, the transmitter needs to be confirmed to shut down! It can prevent the receiver from inadvertently shutting down and actively enter the F/S state, so that the model can make unexpected and dangerous actions to avoid loss and damage.**

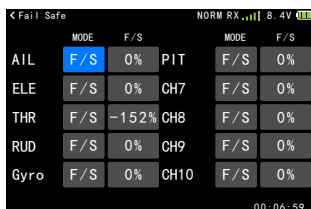



## S.BUS Servo

The S.BUS servo can memorize its own channel and different settings. the servo channel could be set through connecting servo on ET10.

### Notice:

- 1 Before using this function, you need to enable the [Telemetry] function and the receiver is connected normally.
- 2 When setting, only one BUS servo can be connected for setting at a time.
- 3 When using the S.BUS servo, ensure that the power supply is sufficient, otherwise the servo will have an abnormal situation such as unstable output!

### Interface path:

**WFLY** → Linkage Setting → **W.BUS Servo**

**Setting method:** The use of W.BUS function is mainly to allocate channel parameters for BUS servo, which is divided into three main steps.

**Prerequisite:** The transmitter and receiver are linked (turn on telemetry) and linkage normally.

### First, read the S.BUS servo ID.

Connect the S.BUS servo to the "W.BUS2 slot" of the receiver and the transmitter clicks the "Read" button.

### Second, the channel allocation.

In the "Function" setting item, select the corresponding channel according to the function of the servo. Click the "Write" button, set the servo channel and complete the parameter saving, and exit the setting interface.

### Third, verify the servo channel.

Turn on the monitor, connect the servo to the "PPM/W.BUS" interface, and operate the stick or switch knob (currently connected to the channel set by the servo).



1 read the S.BUS servo ID



2 channel allocation



3 verify the servo channel

## PPM/W.BUS

Switching the output mode of receiver PPM/W,BUS(the 8th slot)

**Notice:** PPM mode(RF209S). The 8th slot outputs a standard 2048 resolution, 8 channel PPM signal.

### Interface path:

**WFLY** → Linkage Setting → **PPM/W.BUS**

### Setting method:

Press the button - press the plus or minus button or the confirm button to switch the mode. The Back button exits the interface and saves the settings.

Touch screen - click the button to switch modes. Click on the function name in the upper left corner to exit the interface and save the settings.

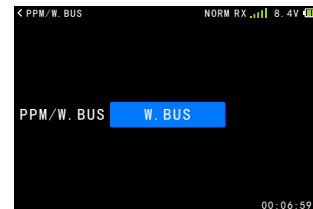

## Rx port setting

Receiver port setting function could be applied to receiver ports flexibly

### Interface path:

**WFLY** → Linkage Setting → Rx port setting

**\*W.BUS2 could only be set to the receiver port where marked "W.BUS2" .(Different receivers could be set as different parameters, please refer to the receiver lable mark.)**

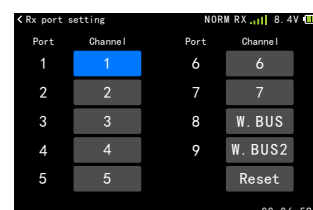

## Monitor

The monitor displays the servo output corresponding to all channels and displays the servo action.

**Interface path:**

**WFLY** → **General Menu** → **Monitor**

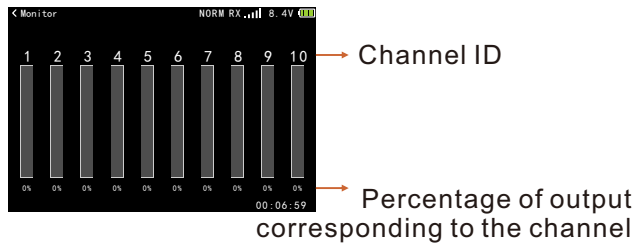

## Sub-Trim

This function is a function to trim the neutral position of each servo. In addition, the neutrality of the rudder surface can be trimmed while the connecting rod is connected.

When starting the [Sub-Trim] setting, you must firstly sub trim each channel (checked by the monitor) to the center position.

Default trim value is 0;  
Adjusted range is -240+240

**Interface path:**

**WFLY** → **General Menu** → **Sub-Trim**

**Setting method:**

Press the key - arrow keys to select the setting item, and press the plus or minus key to adjust the value. Exits the interface and saves the settings after the back button

Touch Screen - Click the button to select the setting item and click the Settings button on the right to edit the value. Click on the function name in the upper left corner to exit the interface and save the settings.

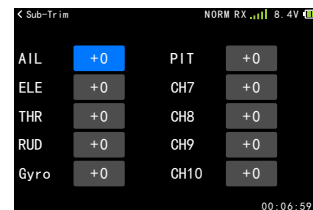

## Servo Reverse

The servo reverse function can change the correspondence between the direction of the servo of a certain channel and the direction of the stick. For CCPM mode helicopters, be sure to read the [Swash] section before setting the servo reverse. Be sure to Complete the servo reverse before data entry.

If the model aircraft you are using is a airplane aircraft or a glider, please refer to the relevant chapters in the product manual for specific setup instructions.

**Interface path:**

**WFLY** → **General Menu** → **Servo Reverse**

**Setting method:**

Press the key - arrow keys to select the setting item. Press the plus or minus key or the confirmation key to switch the mode. Exits the interface and saves the settings after the Back button

Touch screen - click the button to switch modes. Click on the function name in the upper left corner to exit the interface and save the settings.

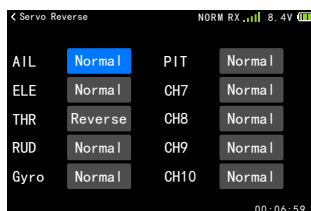

## Timer

The ET10 has two separate timers available. The timer can be used for a variety of timings, such as the running time of the engine or power battery, race timing, and the like.

You can set the timing, countdown, and the beep will sound if the set target timing is completed. (When the countdown or positive timing reaches the last 20 seconds, a continuous short beep will start, and when the timing is finished, a long beep will sound. The timing will sound every minute.)

Can only reset timer by resetting the timer.

**The control methods can be assigned the following three types:**

**1 Throttle:** Set the position where the throttle is turn on. The start and stop of the timer is controlled by the throttle stick ("Above 50%": the throttle is above 50% to start the timer, otherwise the timer is paused; "Below 50%": the throttle is below 50% to start the timer On the contrary, the timeout is suspended.)

**2 Switch:** Set the name of the control switch. The start and pause of the timer are controlled by the switch.

**3 Power on:** The timer starts when the transmitter is turned on.

Timer on the standby interface:

Timer 1 cannot be set to switch control

Timer 2 belongs to the controllable timer

described on this page.

**Interface path:** WFLY → General Menu → Timer  
Setting method:

Press the key-arrow keys to select the setting item, press the plus or minus key to adjust the value, and press the enter key to switch the function status and mode. Exits the interface and saves the setting after the click Back button.

Touch Screen-Click the button to select the setting item and switch the setting item status and mode, click the value and click the setting button on the right to edit the value. Click on the function name in the upper left corner to exit the interface and save the settings.

(Acquisition of throttle position: Select the value of the throttle position, click the "confirm" button or click the button where the value is located to obtain the parameter of the stick position!)

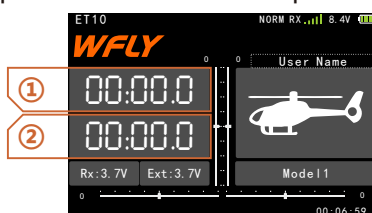

1 When selected, "Confirm button" and tap and hold to stop timing and reset the value, click to start or pause timing.

2 When selected, "Confirm button" and press & hold to reset the value.

Throttle, switch, power on

Click to switch

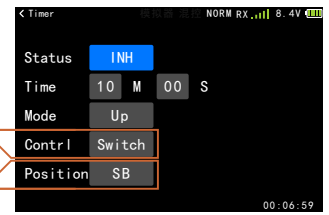

When set to "Throttle" control, the interface is as follows:

Throttle Up

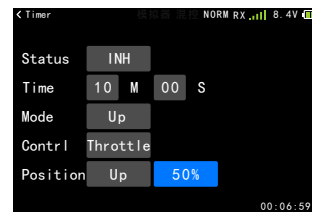

When the position is "Up", click the parameter (button) on the right to intercept the trigger position. For the example of the figure, set to 50%, when the throttle is greater than (above) the set position, the status is on and the timer starts counting.

Throttle Down

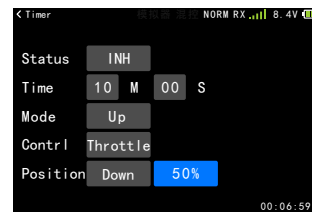

When the position is "down", click the parameter (button) on the right to intercept the trigger position. For the example of the figure, set to 50%, when the throttle is less than (below) the set position, the status is on and the timer starts counting.

## Dual Rate

**Airplane, multicopter:** This function can be used to switch the end point of each channel of the aileron, elevator and rudder to the two position/third position switch.

- The rudder angle adjustment can be set for each direction of the switch and the left and right (up and down) directions of each channel. Ratio (D/R): This function can set the rudder angle of each channel such as aileron, elevator and rudder to two-speed switch.

- The end point adjustment can be set for each direction of the switch and the left and right (up and down) directions of each channel. EXP: Ailerons, elevators, throttles, rudders, etc. The stick action near the neutral point can be set to be slower or more sensitive, and the action curve can be set according to the needs of the maneuver.

- When the set value is negative, the action near the neutral position becomes slow. It becomes sensitive when the value is set to a positive value.

- D/R can set the respective ratios, and set the direction of the switch and the left and right (up and down) directions of each channel. Switch selection: D/R ratio for setting aileron, elevator, rudder and other channels and EXP switch can be selected from switches SA~SD.

Note: The DR mode of all channels is controlled and switched by the same switch set.

**Helicopter:** This function is used when the aileron, elevator, and rudder channels need to be switched to use an end point other than the initial setting in different flight operations.

- The end point adjustment can be set separately for each switch direction and each condition.

- \* Travel (EXP): The aileron, elevator, throttle, and rudder can be set to be slow or sensitive in the vicinity of the neutral. The action curve can be set according to the needs of the maneuver.

- Press the "-" button, and the action near the neutral position becomes slow. Pressing the "+" button will become sensitive.

- EXP setting can be made separately for each gear of the switch

**Interface path:** WFLY→General Menu→Dual Rate

### Terminology explanation and usage reference:

EXP (Exponential), the exponential curve, is used to convert the linear relationship between the stick and the rudder amount into an exponential curve. That is to change the rudder sensitivity of the mast to the upper and lower 1/2 position at the midpoint and the 1/2 to the top and bottom of the mast. The EXP function generally needs to switch between different setting values with the size action (D/R) switch.

1 Assuming that EXP A EXP B is set to 0%, it is equivalent to turning off the curve. At this time, the stick is pushed and the servo will make corresponding linear motion.

2 Assuming that EXP A EXP B is set to -50%, push the stick up and down, you can see that when the upper and lower push rods are within 1/2 position, the servo

action is obviously set to 0% smaller than EXP A EXP B. A lot, and the putter is greater than the upper and lower 1/2 position, the servo action is significantly larger than the EXP A EXP B 0%. At this time, the linear relationship between the stick and the rudder amount has been converted into a downward bending exponential curve relationship.

3 Assuming that EXP A EXP B is set to 50%, push the stick up and down, you can see that when the upper and lower push rods are within 1/2 position, the servo action is obviously set to 0% larger than EXP A EXP B. A lot, and when the putter is larger than the upper and lower 1/2 position, the action of the servo gear is obviously much smaller than 0%, and the linear relationship between the stick and the rudder amount is converted into an exponential curve relationship of upward bending. However, the maximum rudder amount is the same. The larger the parameter setting value of EXP, the more obvious the curve changes.

### How to make the Dual Rate (D/R) and EXP make the best effect?

1 Suppose we set 2 different actions (D/R) for the elevator. The ratio A and ratio B are both set to 100%. This action is used for aerobatics (eg, somersault flight);

2 Both the rate A and the rate B are set to 50%, and this action is used for normal practice flights.

3 These two modes seem to solve the control of the size of the rudder, but ignore the determination of the maximum rudder, will change the stick sensitivity at the same time.

4 For example, when the D/R rate A rate B is 100%, the servo needs to be rotated by 10 degrees, only the 1/3 position of the push rod is required, but the rudder is required when the D/R rate A rate B is 50%. Rotating the machine by 10 degrees requires a push rod to 2/3. The difference in operation makes it difficult for the pilot to adapt. Causes the same stick position to be different.

5 With the use of the EXP parameter, the problem of 4 above can be solved very well, and the two action (D/R) values correspond to two different EXP values. For example, the rate A and the rate B are both 100% and the EXP A EXP B is -60%.

6 Both the rate A and the rate B are 50% and the EXP A EXP B is 0%. In this case, the servo needs to be rotated by 10 degrees, and the position of the push rod in the two D/R modes is almost close. Maintaining the consistency of the mast sensitivity of the two D/R modes in the normal flight small amplitude (less than 1/2) rod amount correction, without affecting the maximum rudder amount (aerobatics, etc.), the above example is only Explain the set value of the hypothetical use of the size action. Actual use requires several flight adjustments to determine the parameters to achieve the best results.

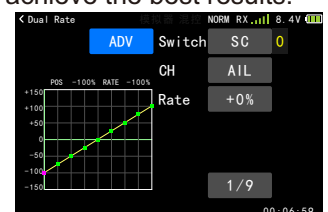
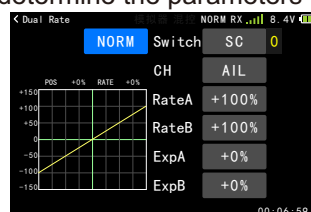

## End Point

The end point function is used to set the initial rudder angle of each rudder surface of the body. The amount of servo movement can be adjusted separately on the left and right sides.

The left and right direction of the servo can be adjusted between 30% and 155%, and the maximum limit can be adjusted between 0% and 155%.

**Note:** The actual rotation of each channel servo is displayed on the interface. The display of the neutral position is based on the setting value of Sub-Trim. Therefore, the adjustment of the Sub-Trim will affect the upper and lower limit points of the servo.

**Enter the interface:** WFLY → General Menu → End Point

Setting method:

Press the key- arrow keys to select the setting item, press the plus or minus key to adjust the value, and press the confirm key to switch the function status and mode. Exit the interface and saves the settings after click the Back button

Touch Screen-Click to select the setting item and switch the setting-item status and mode, click the value and click the setting button on the right to edit the value. Click on the function name in the upper left corner to exit the interface and save the settings.

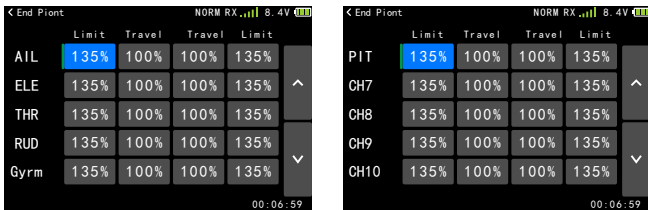

Green cursor:  
Display the current position direction of the stick, knob, switch, etc., no cursor in the middle of the channel

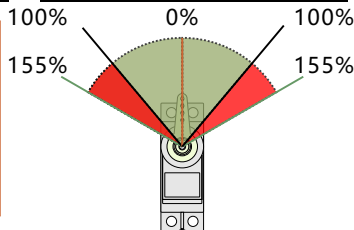

## Aux Channel

The auxiliary channel function can change the switch that has been set on the CH5-CH10, and the knob can be changed according to personal preference (can be turned off). It can be selected from the switches T1-T4, SA-SD, V1 knob, and V2 pulsator. When the control channel of the auxiliary channel is set to T1-T4, you can set the step value of the trim in the [Trim Step] function, or set the 2nd or 3rd switching mode.

**Enter the interface:** WFLY → General Menu → Aux Channel

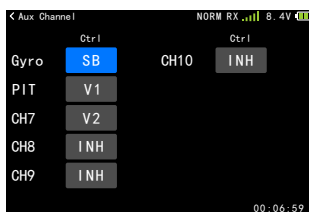

## Trim Step

The trim step shows the adjustment step value of the trim adjustment button (T1\T2\T3\T4). The step value of the trim adjustment can be selected between 1 and 250. According to the performance of the model type and the purpose of the trim adjustment, a more suitable step value can be set, and the conventional model model is set between 2 and 10.

**Note:** The larger the step value, the fewer times you need to finish the entire range change when trimming.

**V2:** Press down twice to automatically return to the middle. Normal, it will automatically return to the middle after release. P&T will not automatically return to the neutral.

**Linkage:** For example, after T1 is linked, the trim step of channel 1 will follow the action.

**T1-T4:** When T1-T4 is needed, when the switch is used, the switch bar is set to the required servo position (2nd servo or 3rd servo). After the setting is finished, the trim state will be displayed in the home interface.

**Enter the interface:** WFLY → General Menu → trim Step

Setting method:

Press the key-arrow key to select the setting item, and press the plus or minus key to adjust the value. Exit the interface and saves the settings after click the Back button

Touch Screen-Click to select the setting item and click the value, click the setting button on the right to edit the value. Click on the function name in the upper left corner to exit the interface and save the settings.

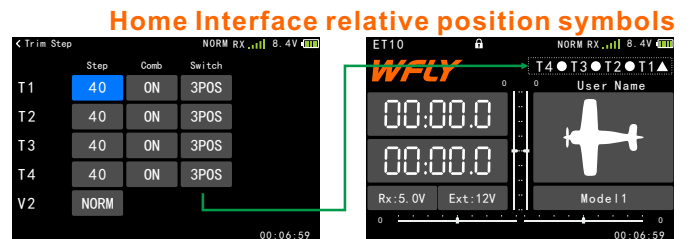

## Channel Delay

The channel delay function is mainly used for realistic actions, such as the retraction of the landing gear. The channel delay is used to reduce the response speed of the output channel. The setting range is 0 to 4 seconds. The default is 0 seconds. The delay time from the low end to the highest end of the corresponding channel rocker position is the set time.

**Note:** The larger the value displayed on the interface, the greater the delay and the slower the action output.

**Enter the interface:** WFLY → General Menu → Channel Delay

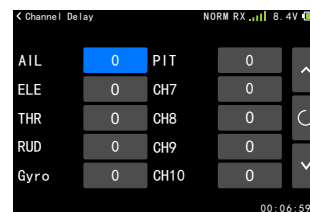

## Program Mix 1-3

The program mixes is used to correct the special properties of the aircraft, and is also used to control the special travel combination. The mixing control means that the auxiliary channel is driven by the main channel.

The mixing rate can be adjusted freely so that the aircraft's wrong tendency can be effectively corrected. You can set the mixing switch to manually control the activation and deactivation of the mixing.

The mismatch mode is controlled by a fixed or pre-set offset to the target channel servo. The program mix contains powerful linkage settings that enable special or programmable mixing functions. These functions can be separated. Set to the main channel and the auxiliary channel.

### Mixed channel

1. The default settings of the main channel and the auxiliary channel are preset, so please set the mixing channel firstly.
2. If main channel setting has set a channel or switch/knob, the mixing amount on the side of the auxiliary channel needs to be set. After the mixing amount is set, the servo of the auxiliary channel is only biased according to the set amount. .
3. As the main channel, in addition to selecting the channel, you can also set the switch, or the knob as an input.

### Switch selection

Control switch selecting for program mixes: Select from switch SA~SD and throttle stick. If you select the throttle stick as a switch, you can set the throttle position and the direction of motion.

**Interface path:** WFLY→Model Menu→Program Mix 1,2,3

### Setting method:

Press the key-Press the arrow key to select the setting item. Press the plus or minus key to adjust the value (when setting the position of the control throttle, select the value and press the confirm key to get the position parameter!). Click the Back button to exit the interface and save the settings.

Touch screen-Click to select the setting item switching option, (Click the value) and click the setting button on the right to edit the parameters (when setting the position of the control throttle, click the value to get the position parameter!). Click on the function name in the upper left corner to exit the interface and save the settings.

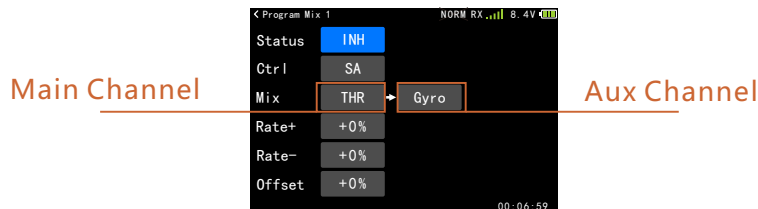

## Curve Mixes 1-2

The mixing control is used to correct the special properties of the aircraft, and is also used to control the special stroke combination. The mixing control means that the auxiliary channel will be driven by the main channel.

The mixing curve can be adjusted freely, and the mixing can be set by a 9-point curve. so an error tendency of the aircraft can be effectively corrected. You can set the mixing switch or let the mixing function work at any time.

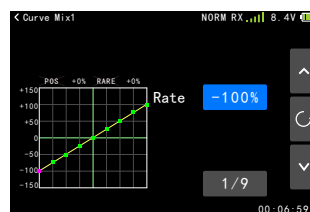



### Throttle Hold(Airplane)

The throttle hold function can fix the throttle servo in the low speed position when the throttle cut to land is executed, and the throttle hold position can be adjusted within  $\pm 75\%$ . The preset switch (custom) is responsible for switching this function.

**Note:** The throttle hold position needs to be determined according to the specific application of the model.

**Interface path:** WFLY  $\rightarrow$  Model Menu  $\rightarrow$  Throttle Hold

**Setting method:**  
Press the key- Press arrow key to select the setting item, and press the plus or minus key to adjust the value. Click the Back button to exit the interface and save the settings.

**Touch Screen-Click** to select the setting item switching option, (click the value) and click the setting button on the right to edit the parameter. Click on the function name in the upper left corner to exit the interface and save the settings.



### AIL Differential(Airplane)

When ailerons are controlled by two servos, the ratio of upper and lower end point of the left and right ailerons can be independently adjusted.

Connect left ailerons to 7CH and right ailerons to 1CH.

**Note:** aileron differential, flaperon, Elevon, only one of the three could be chosen at a time! You cannot enable both at a time, and a warning screen will pop up!

**Enter the interface:** WFLY  $\rightarrow$  Model Menu  $\rightarrow$  Aileron Differential

**Setting method:**  
Press the key- Press arrow keys to select the setting item, and press the plus or minus key to adjust the value. Click the Back button to exit the interface and save the settings.

**Touch Screen-Click** to select the setting item switching option, (click the value) and click the setting button on the right to edit the parameter. Click on the function name in the upper left corner to exit the interface and save the settings.

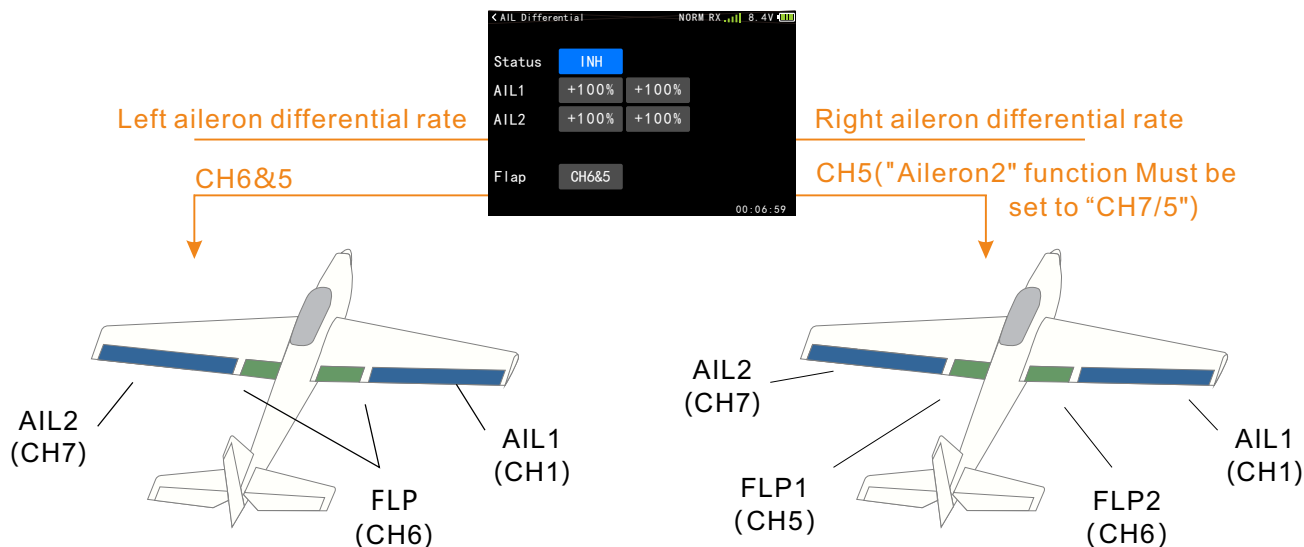



### Aileron 2(Airplane)

Assign the channel output position of the aileron-2. The aileron 2 and the aileron are mixed to form a flap, and the aileron 2 is required if the flap function is required. The aileron 2 can be provided as a channel 5 or a channel 7.

Enter the interface: **WFLY** → **Model Menu** → **Aileron 2**

Setting method:

Press the button--press the plus or minus button to adjust the value. Click the Back button to exit the interface and save the settings.

Touch Screen - Click to select the setting item to switch options. Click Function name (the top left corner) to exit interface and save settings.



### Fly Mode(Airplane)

The initial setting switch of the flight mode switch (Normal, Idle 1, Idle 2) is SC. Before setting other functions, please set the fly mode function firstly.

Note: ● After the function is started, when the function control switch is set to the third position, the initial setting switch and the square are: normal (Gear Up), Idle 1 (Gear Middle), and Idle 2 (Gear Down). ● When the function control switch is set to two positions, the functions are only: normal (Gear Up) and Idle 2 (Gear Down).

Enter the interface: **WFLY** → **Model Menu** → **Fly Mode**



Normal: Fly mode 1, corresponding to the throttle curve of the normal mode.

Idle 1: Fly mode 2, corresponding to the throttle curve of the effect 1 mode.

Idle 2: Fly mode 3, corresponding to the throttle curve of the effect 2 mode.

The functions that need to be switched by fly mode are as follows:

When using the following functions, you need to preset the fly mode control switch and set the curves or parameters of different fly modes according to the actual use of the model.

[Throttle Curve] [Multicopter] [Throttle Curve]

### Throttle Cut(Airplane)

It is easy to use the throttle cut function to turn off the engine. It is only necessary to toggle a switch in the idle state to achieve engine stall or motor stop. After the throttle cut function is enabled, the throttle cut or the ESC's fully flameout position can be adjusted. After the function is activated, regardless of the throttle lever position, the throttle output remains at the set position. The cut function does not start in the high speed throttle state, avoiding erroneous operation. For safety reasons, it is recommended to set the throttle cut function.

**Note:** After the throttle cut function is enabled, the function is turned off again. The throttle action determines that the sticker has no power output when it is in the high position. Only when the oil level (servo position) is increased from the low position of the throttle, the normal throttle output can be restored!

Interface path: **WFLY** → **Model Menu** → **AIL Differential**

Setting method:

Press the key - Press arrow keys to select the setting item, and press the plus or minus key to adjust the value. Click the Back button to exit the interface and save the settings.

Touch Screen - Click to select the setting item switching option, (click the value) and click the setting button on the right to edit the parameter. Click on the function name in the upper left corner to exit the interface and save the settings.

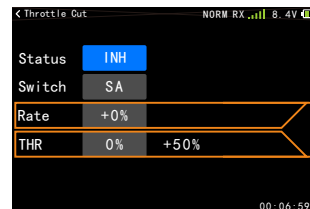

Adjust the throttle cut position (here adjust the throttle servo or the rate of the position where the ESC is completely cut.)

The throttle position where the function is released (the value on the right indicates the current throttle stick position.)



## Throttle Curve(Airplane)

Through the 9-point curve, the throttle output curve is adjusted for the action of the throttle stick to achieve the optimal flight state of the engine (motor).

\* Each fly mode can set the curve.

The control switch needs to be set in [Model Menu] → [Fly Mode].

The curve control switch for throttle hold needs to be set in [Model Menu] → [Throttle Hold].

**Note:** When starting the engine, be sure to start the engine at normal idle down in normal mode.

**Enter the interface:WFLY → Model Menu → Throttle Curve.**

Setting method:

Press the - arrow keys to select the setting item, and press the plus or minus key to adjust the value. The Back button exits the interface and saves the settings.

Touch Screen - Click to select the setting item and click the value, click the setting button on the right to edit the value. Click on the function name in the upper left corner to exit the interface and save the settings.

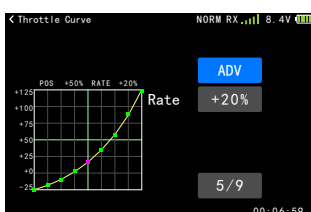
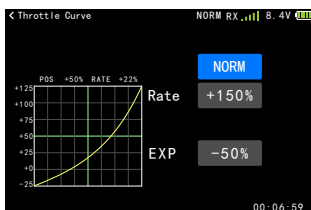

## Flap Trim(Airplane)

Make Channel 6 as trim step function.

**Note:**The “Flap Trim” function uses the “V1 knob” for operation control, which can adjust the travel of the trim lever. “V1 knob” can customize the switch or knob in [Aux Channel].

**Enter the interface:WFLY → Model Menu → Flap Trim**

Setting method:

Press the - arrow key to select the setting item, and press the plus or minus key to adjust the value. Click the Back button to exit the interface and save the settings.

Touch screen - click to select the setting item switching option, (click the value)

Click the Settings button on the right to edit the parameters. Click on the function name in the upper left corner to exit the interface and save the settings.

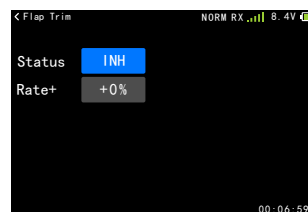

V1 Neutral



V1 Rotary

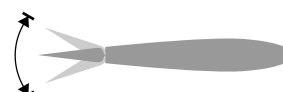



### ELE to Flap (Airplane)

This function is used for the mixing of the elevator to the flap action. Generally, it is set to mix the elevator up and the flaps down. A model airplane for fun flying, for small-scale squashing.

**Note:**The rate of the upper/lower sides can be adjusted individually.

Enter the interface: **WFLY** → **Model Menu** → **ELE to Flap**

Setting method:

Press the - arrow keys to select the setting item, and press the plus or minus key to adjust the value. Click the Back button to exit the interface and save the settings

Touch screen - click to select the setting item switching option (click the value). Click the Settings button on the right to edit the parameters. Click on the function name in the upper left corner to exit the interface and save the settings.

(ELE to Flap) Upward rate

(ELE to Flap) Downward rate

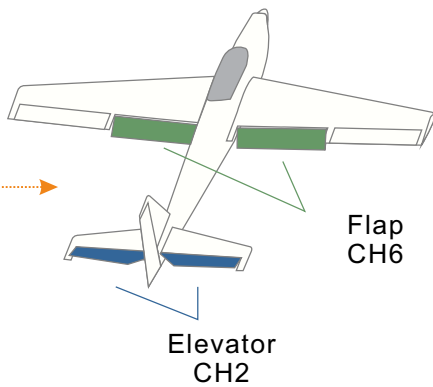
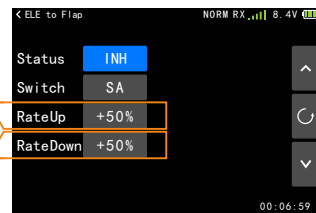

### Flaperon (Airplane)

The two ailerons are used in the ailerons, so that the ailerons can also have the mixing function of the flaps. As the ailerons act, the ailerons are lifted at the same time. When this mixing and air brake are used together, the speed can be reduced when landing, and it is effective when flying in a narrow place.

Connect the right aileron servo to CH1 (aileron) and the left aileron servo to CH6 (flaps).

**Notice:**The upper and lower rudder angles of the left and right aileron rudder surfaces can be adjusted separately.

The amount of left and right flap motion can be adjusted separately.

The flap aileron mixing control, the aileron differential, and the lifting aileron mixing control cannot be started at the same time. When other mixing controls have been enabled, the pop-up window will display conflicts on the interface. Please set other mixed mixing controls to be disabled first. Then set the flap aileron mixing to be enabled.

Enter the interface: **WFLY** → **Model Menu** → **Flaperon**

Setting method:

Press the - arrow keys to select the setting item, and press the plus or minus key to adjust the value. Click the Back button to exit the interface and save the settings.

Touch Screen-Click to select the setting item switching option, (click the value) and click the setting button on the right to edit the parameter. Click on the function name in the upper left corner to exit the interface and save the settings.

Aileron1 (CH1)  
Aileron2 (CH6)

Flap2 (CH1)  
Flap1 (CH6)

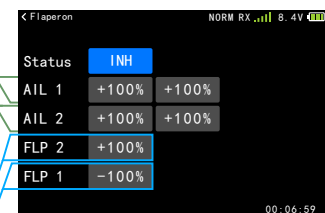

Aileron stick left rate

Aileron stick right rate

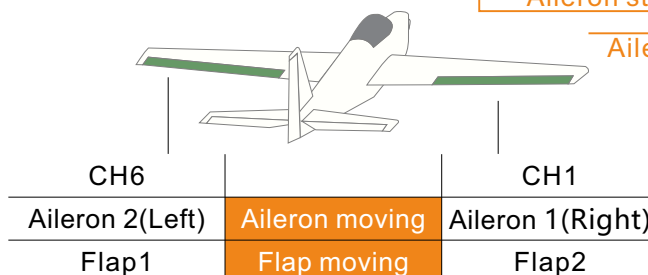



### Elevon (Airplane)

It is used for the combination of aileron and elevator functions, such as a delta wing aircraft, a tailless aircraft, and a profiled machine. Left aileron connecting channel 1 (aileron) servo, right aileron connecting channel 2 (elevator) servo.

**Note:**

The aileron and elevator movements can be adjusted separately for ELE to Flap, Elevon, and the V-Tail, which cannot be turned on at the same time. When other mixing controls are enabled, the mixing will pop up on the interface.

For function conflict prompts, please firstly set other mixed function to be inhibited.

Enter the interface: **WFLY** → **Model Menu** → **Elevon**



It is recommended to set the stick while checking the amount of movement. If the action amount is set too large, after the aileron and the elevator action are superimposed, the range of the servo may be exceeded, resulting in no action and no reaction.



## Air Brake (Airplane)

This function is used for landing or in-flight descent actions.

- Generally, the aileron opens upward when used as a brake.
- When the operation mode is set to "manual", the air brake is activated by the switch operation. When the operation mode is set to "Throttle", the switch is turned on and the throttle stick is lower than the set position, the air brake is activated and linear action is performed.
- After selecting "Throttle" mode, the throttle stick can control CH3 and air brake.
- To adjust the amount of movement during use in the "throttle" mode, perform the throttle stick in the lowest position (maximum brake).

**Enter the interface: WFLY → Model Menu → Air brake**

Setting method:

Press the - arrow keys to select the setting item, and press the plus or minus key to adjust the value. Click the Back button to exit the interface and save the settings.

Touch Screen - Click to select the setting item switching option, (click the value) and click the setting button on the right to edit the parameter. Click on the function name in the upper left corner to exit the interface and save the settings.

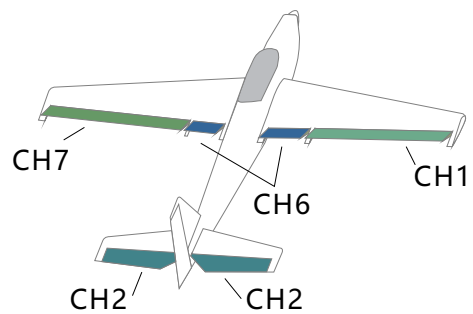
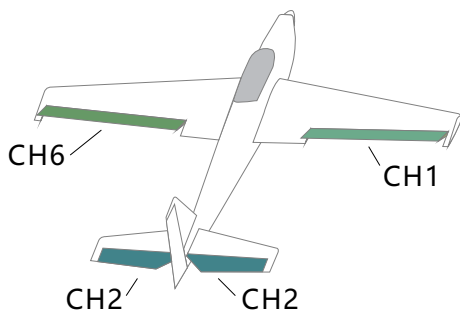

	Normal	Flaperon	Ail Differential
AIL1(CH1)	--	AIL1	AIL1
ELE(CH2)	ELE	ELE	ELE
Flap(CH6)	Flap	AIL2	Flap
AIL2(CH7)	--	--	AIL2



## Ailvator (Airplane)

This function makes the elevator get the function of an aileron, and the performance of the aircraft snap roll is improved. The aileron elevator is to make the two rudder surfaces on the normal layout or the V-Tail like the ailerons, moving upwards and the other side. The lower movement, on the V-tail, is called the directional elevator, because they are the same on the left and right. In a typical application, the aileron elevator is linked with the aileron, especially on the aircraft of the large wingspan. Maximize the snap roll effect.

**Notice:**

The amount of motion of the ailerons and elevators can be adjusted separately. Depending on the connection, the direction of motion will be different, so check the direction of the operation carefully.

Ailvator, V -Tail, Elevon, can only be activated one at a time! Open the second one will have a pop-up warning!

**Interface Path:** WFLY → Model Menu → Ailvator

Setting method:

Press the - arrow keys to select the setting item, and press the plus or minus key to adjust the value. Click the Back button to exit the interface and save the settings.

Touch Screen - Click to select the setting item switching option, (click the value) and click the setting button on the right to edit the parameter. Click on the function name in the upper left corner to exit the interface and save the settings.

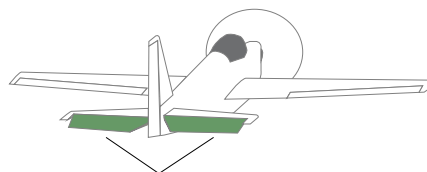

AIL3(CH2)

	CH2
AIL Moving	AIL3
ELE Moving	ELE 1



## V-Tail (Airplane)

This function makes the elevator get the function of an aileron, and the performance of the aircraft roll is improved. The aileron elevator is to make the two rudder surfaces on the normal layout or the V-Tail like the ailerons, moving upwards and the other side. The lower movement, on the V-tail, is called the directional elevator, because they are the same on the left and right. In a typical application, the aileron elevator is linked with the aileron, especially on the aircraft of the large wingspan. Maximize the effect.

**Note:** Ailvator, V-Tail, and Elevon, only one can be activated! Opening the second one will have a pop-up warning!

**Enter the interface:** WFLY → Model Menu → V-Tail

Setting method:

Press the - arrow keys to select the setting item, and press the plus or minus key to adjust the value. Click the Back button to exit the interface and save the settings.

Touch Screen-Click to select the setting item switching option, (click the value) and click the setting button on the right to edit the parameter. Click on the function name in the upper left corner to exit the interface and save the settings.

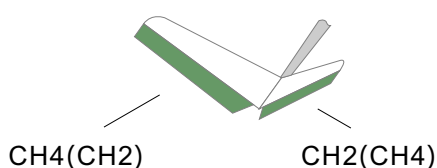

	CH2	CH4
ELE Moving	AIL1	ELE2
RUD Moving	ELE2	RUD1

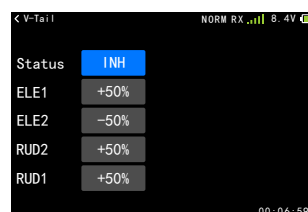



## Throttle Hold (Helicopter)

The throttle hold setting function can fix the throttle servo in the low speed position when the flameout is executed, and the throttle hold position can be adjusted within  $\pm 75\%$ . The preset switch (custom) is responsible for switching this function.

**Note:** The throttle hold position needs to be applied according to the specific conditions of the model.

**Interface Path:** WFLY → Model Menu → Throttle Hold

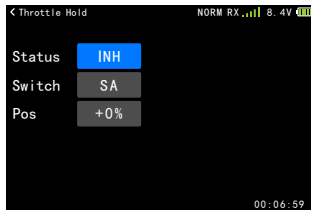

### Setting method:

Press the - arrow keys to select the setting item, and press the plus or minus key to adjust the value. Click the Back button to exit the interface and save the settings.

Touch Screen - Click to select the setting item switching option, (click the value) and click the setting button on the right to edit the parameter. Click on the function name in the upper left corner to exit the interface and save the settings.

## Throttle Curve (Helicopter)

This function adjusts the throttle output curve for the throttle stick motion through a 9-point curve to achieve the best flight/engine speed. Each point can be adjusted from -25 to 125%.

- The curve can be set under normal, Idle 1, Idle 2, and throttle hold conditions.
- The curve can be set under normal, Idle 1, Idle 2, Throttle hold switch, preset in the fly mode interface. (Normal throttle curve adjustment method) The ordinary throttle curve is "the basic throttle curve made with hovering as the center. With the normal pitch curve, the number of engine revolutions is fixed, so that the upper and lower control can be used for the simplest purpose". (Normal, Idle 1, Adjusting Method of Throttle Curve of Idle 2) The Idle curve setting is to allow the helicopter to maintain a certain number of revolutions even when the pitch is operated while the helicopter is flying at high altitude. Match the movement curve of the tendon, roll, 3D, etc., and then use the normal, Idle 1, and Idle 2 separately according to different actions.

**Note:** You must start the engine with normal idle speed under normal mode (Shut down Idle) while the engine is starting

**Interface Path:** WFLY → Model Menu → Throttle Curve

### Setting method:

Press the - arrow keys to select the setting item, and press the plus or minus key to adjust the value. Click the Back button to exit the interface and save the settings.

Touch Screen - Click to select the setting item switching option, (click the value) and click the setting button on the right to edit the parameter. Click on the function name in the upper left corner to exit the interface and save the settings.

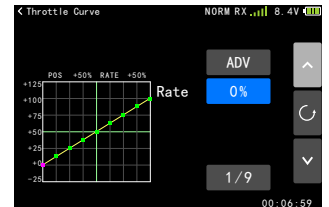
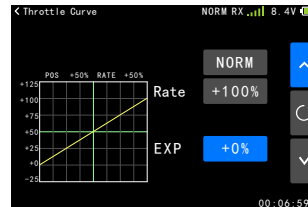

### Throttle curve setting example:

- \* Curve Edit Point: In Advanced Curve Editing, click the Curve Point Value button to switch.
- \* Throttle ratio (RATE); throttle position (POS).
- \* During the actual setting process, please set according to the values specified in the model helicopter manual. and click the setting button on the right to edit the parameter. Click on the function name in the upper left corner to exit the interface and save the settings.

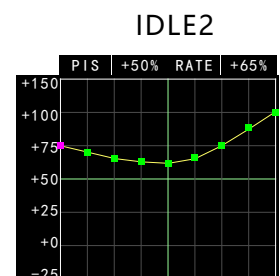
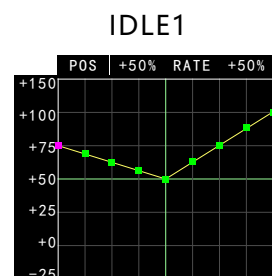
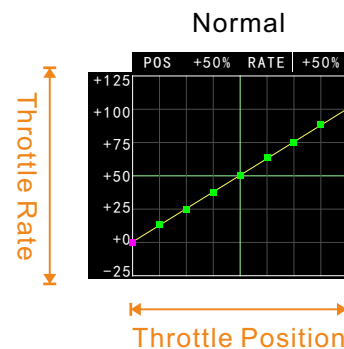



## Swash (Helicopter)

When the swash type is selected as HR3 (120°), HE3, HN3 (120°), H-3, this function can be used to adjust the end point. The ailerons, elevators, end point and directions of the pitch can be adjusted.

### Note:

If the end point is set too large, the structure of the connection may be damaged during the compound operation. Due to the wrong direction of the helicopter connection, etc., even if the servo is connected in accordance with the position specified in each of the above swash types, the swash rate may not operate correctly. Please adjust the operation of each servo described in the helicopter instruction manual with [Servo Reverse]. In addition, if the aileron, elevator, and pitch are reverse-adjusted, pay attention to the change of the rate polarity in the AFR function of the swash.

### Interface Path: WFLY → Model Menu → Swash

#### Setting method:

Press the - arrow keys to select the setting item, and press the plus or minus key to adjust the value. Click the Back button to exit the interface and save the settings.

Touch Screen - Click to select the setting item to switch options, (click the value)click the right set key to edit the parameters. Click on the function name in the upper left corner to exit the interface and save the settings.

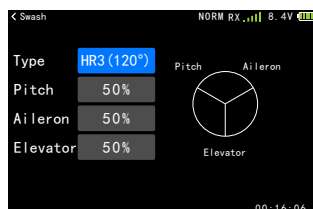
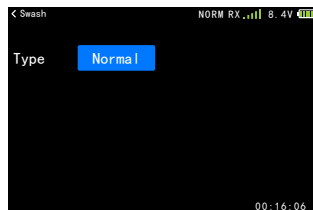

Switching swash types

Adjust Servo

## Fly Mode(Helicopter)

The initial setting switch of the fly mode switch (Normal, Idle 1, Idle 2) is SC. Before setting other functions, please set the fly mode function firstly.

### Note:

• After the function is activated, when the function control switch is set to the third position, the initial setting switch and mode are: normal (gear position), Idle 1 (position), Idle 2 (under gear).

• When the function control switch is set to two position, the functions are only: normal (on gear) and Idle 2 (under gear).

### Enter the interface: WFLY → Model Menu → Fly Mode .

#### Setting method:

Press the - arrow keys to select the setting item, and press the plus or minus key to adjust the value. Click the Back button to exit the interface and save the settings.

Touch Screen - Click to select the setting item to switch options. Click on the function name in the upper left corner to exit the interface and save the settings.

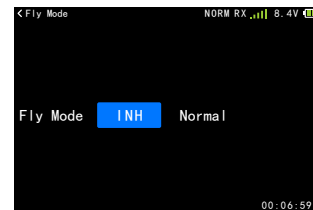

Normal: Used when hovering.

Idle 1: Air route, somersault and snap roll

Idle 2: 3D, fly back

Locking: Throttle lock mode, the function of switching off the fly mode is as follows:

When using the following functions, you need to preset the fly mode control switch and set the curves or parameters of different flight modes according to the actual use of the model.

[Throttle Curve], [Pitch Curve], [Gyro], [Governor]



## Throttle Cut (Helicopter)

It is easy to use the throttle cut function to shut down the engine. It is only necessary to toggle a switch in the idle down state to achieve engine cut or motor stall. After the throttle cut function is enabled, the throttle cut or the ESC's fully flameout position can be adjusted. After the function is activated, regardless of the throttle lever position, the throttle output remains at the set position. The flameout function does not start in the high speed throttle state, avoiding erroneous operation. For safety reasons, it is recommended to set the throttle cut function.

**Note:** After the throttle cut function is enabled, the function is turned off again. The throttle action determines that the stick has no power output when it is in the high position. Only when the oil level (gear position) is increased from the low position of the throttle, the normal throttle output can be restored!

**Enter the interface:** WFLY → Model Menu → Throttle Cut

Setting method:

Press the - arrow keys to select the setting item, and press the plus or minus key to adjust the value. Click the Back button to exit the interface and save the settings.

Touch Screen - Click to select the setting item switching option, (click the value) and click the setting button on the right to edit the parameter. Click on the function name in the upper left corner to exit the interface and save the settings.

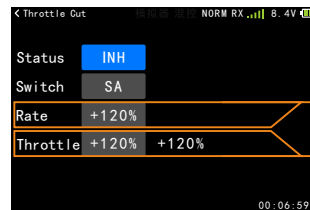

Adjust the throttle cut position (here adjust the throttle servo or ESC completely)

The throttle position where the function is released (the value on the right indicates the current throttle stick position.)

## Pitch Curve (Helicopter)

In order to get the best flight condition when operating the throttle stick, a 9-point pitch curve can be set, and each point can be adjusted from -150% to +150%.

- The pitch curve can be set to normal, stunt 1, stunt 2, and throttle hold.
- Normal, Stunt 1, Stunt 2, Throttle lock switch can be set in the [Fly Mode] and [Throttle Hold] screens in advance.

**Note:**

Regardless of the position of the stunt switch, once the throttle hold switch is turned on, the hover function is prioritized.

The standard curve setting is centered on hovering. With the throttle curve (Normal), the number of engine revolutions is fixed, making the up and down control the easiest.

(Reference adjustment method for stunt 1/2 curve)

The pitch curve at the high throttle position is set to the maximum curve that does not burden the engine. The pitch curve at the low throttle is matched with the roll, the tendon, the 3D, etc., and the curve can be divided according to the action.

Turn on the effect 1/2 curve.

(How to adjust the throttle hold curve)

The throttle hold curve is typically used when the spin landing is lowered. Set the pitch in the middle according to the action of the stick when the pitch is raised.

**[Notice during operation]**

When the engine is started, the special function switch must be turned off to start the engine at idle down.

**Enter the interface:** WFLY → Model Menu → Pitch Curve.

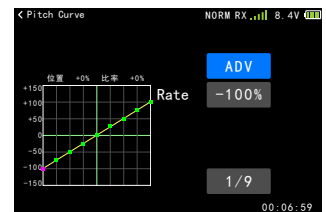
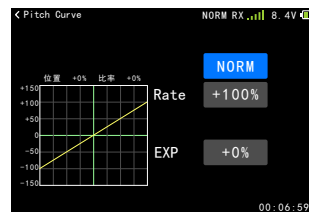

- Example of pitch curve setting:**
- \* Curve Edit Point: In Advanced Curve Editing, click the Curve Point Value button to switch.
  - \* Throttle rate(RATE); Throttle position (POS).
  - \* In the actual setting process, please set according to the values specified in the model helicopter manual.

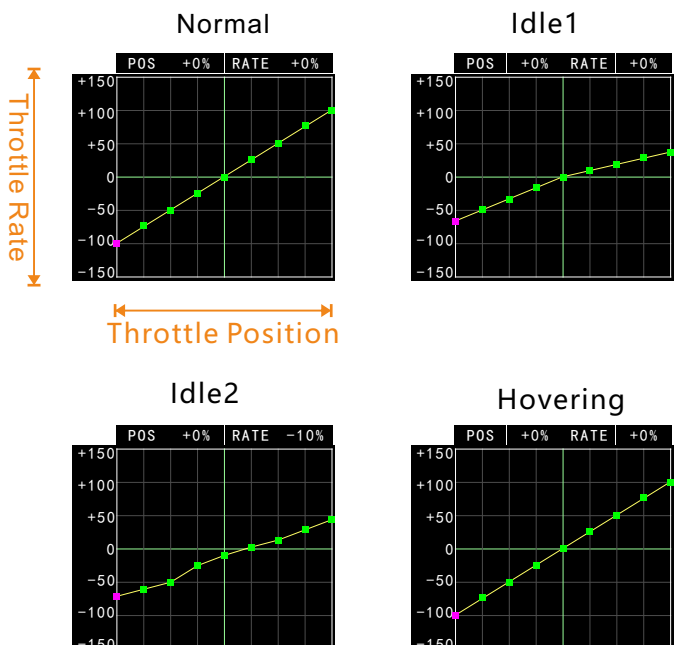



## Idle Down (Helicopter)

The idle down is a function that links the air brake switch with the landing gear switch to make the engine idle. In order to prevent the engine from suddenly stalling during high-altitude flight, the engine idle speed is set higher, and this function is used when the engine idle speed needs to be reduced when landing.

- The amount of descent reduction can be set.
- When the idle speed is reduced, the throttle trim switch is used to adjust the amount of descent reduction.

• The operation switch can be selected from the switches SA, SB, SC, and SD.

**Interface Path:** WFLY → Model Menu → Idle Down

Setting method:

Press the - arrow keys to select the setting item, and press the plus or minus key to adjust the value. Click the Back button to exit the interface and save the settings.

Touch Screen - Click to select the setting item switching option, (click the value) and click the setting button on the right to edit the parameter. Click on the function name in the upper left corner to exit the interface and save the settings.

Set the amount of descent reduction

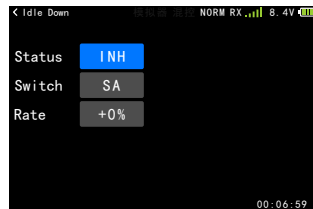

## Gyro (Helicopter)

The gyroscope function is only applicable to the gyroscope with the hold tail function. The transmitter adjusts the sensitivity of the gyroscope. You can set four kinds of gyro sensitivity (switched by flight conditions, normal, hold, stunt 1, stunt 2) and operation mode. (Normal mode, hold mode).

Note: After the gyroscope function is turned on, in [Aux Channel], channel 5 only outputs the rate value set in [Gyro].

**Enter the interface:** WFLY → Model Menu →

### Gyro

Setting method:

Press the - arrow keys to select the setting item, and press the plus or minus key to adjust the value. Click the Back button to exit the interface and save the settings.

Touch Screen - Click to select the setting item switching option, (click the value) and click the setting button on the right to edit the parameter. Click on the function name in the upper left corner to exit the interface and save the settings.

Switch Gyro working mode

Relative fly mode

Gyro output rate

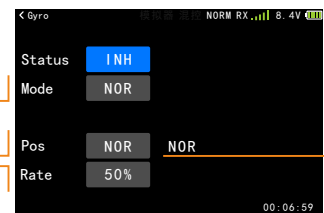

Current mode

## Governor(Helicopter)

The fixed speed governor is used to control the rotor speed of the helicopter, and the speed is adjusted by the transmitter, and the governor signal line is connected to the channel 7. Set the relevant governor side. Refer specifically to the product manual for the fixed speed.

**Enter the interface:** WFLY → Model Menu →

### Governor

Setting method:

Press the - arrow keys to select the setting item, and press the plus or minus key to adjust the value. Click the Back button to exit the interface and save the settings.

Touch Screen - Click to select the setting item switching option, (click the value) and click the setting button on the right to edit the parameter. Click on the function name in the upper left corner to exit the interface and save the settings.

Select speed switching switch

Selected mode speed switching setting

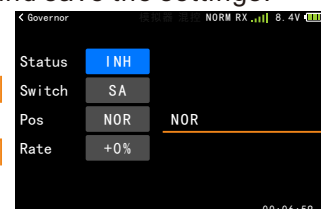

Current mode



## Switch Program (Multicopter)

Switch programming can be composed of 6 different rates of output through a three-position switch and a two-position switch. Each output user can set it according to actual needs, which is suitable for the use of some flight modes by some flight control boards.

For details, please refer to the instruction manual of the flight control board, and set the most reasonable operation mode according to the user's own usage habits.

**Note:**

Please verify the settings after setting. Remove the paddles during commissioning verification to avoid injury to the model.

**Enter the interface: WFLY → Model Menu → Switch Programming**

Setting method:

Press the - arrow keys to select the setting item, and press the plus or minus key to adjust the value. Click the Back button to exit the interface and save the settings.

Touch screen - click to select the setting item switching option, (click the value). Click the Settings button on the right to edit the parameters. Click on the feature name in the top left corner to exit the interface and save the settings

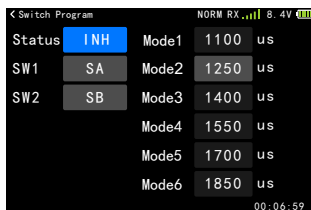

## Throttle Hold (Multicopter)

The throttle hold setting function can fix the throttle servo in the low speed position when the flameout is executed, and the throttle hold position can be adjusted within ±75%. The preset switch (custom) is responsible for switching this function.



**Warn:**

**When debugging the machine, for safety, you must turn on [Throttle Hold] and set the throttle to no power output! Prevent misuse which leads to hurt and endanger the safety of personal property!**

**Note:**

The throttle hold position needs to be applied according to the specific conditions of the model. (Position: The position where the throttle is hold! 0%, the default value!).

**Interface Path: WFLY → Model Menu → Throttle Hold**

Setting method:

Press the - arrow keys to select the setting item, and press the plus or minus key to adjust the value. Click the Back button to exit the interface and save the settings.

Touch Screen--Click to select the setting item switching option, (click the value) and click the setting button on the right to edit the parameter. Click on the function name in the upper left corner to exit the interface and save the settings.

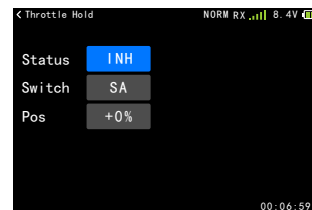



## Fly Mode (Multicopter)

The initial setting of the fly mode switch (Normal, Stunt 1, Stunt 2) is inhibited. Before setting other functions, please firstly set the fly mode function.

**Note:**

- After the function is activated, when the function control switch is set to the third gear, the initial setting switch and direction are: normal (gear position), stunt 1 (position), stunt 2 (down position).
- When the function control switch is set to two position, the functions are only: normal (Gear up) and stunt 2 (Gear down).

**Interface Path:** WFLY → Model Menu → Fly Mode

Setting method:

Press the - arrow keys to select the setting item, and press the plus or minus key to adjust the value. Click the Back button to exit the interface and save the settings.

Touch Screen - Click to select the setting item to switch options. Click on the function name in the upper left corner to exit the interface and save the settings.

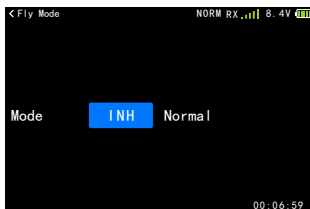

## Throttle Curve (Multicopter)

Through the 9-point curve, the throttle output curve is adjusted for the action of the throttle stick to achieve the optimal flight state of the engine (motor).

- Each switch position can set the curve. Each flight mode corresponds to a set of throttle curves. Need to set the control switch in the Model Menu → Fly Mode

**Note:** When starting the engine, be sure to start the engine at normal idle speed in normal mode.

**Enter the interface:** WFLY → Model Menu → Throttle Curve.

Setting method:

Press the - arrow keys to select the setting item, and press the plus or minus key to adjust the value. Click the Back button to exit the interface and save the settings.

Touch Screen--Click to select the setting item and click the value, click the setting button on the right to edit the value. Click on the function name in the upper left corner to exit the interface and save the settings.

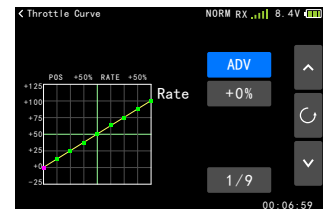
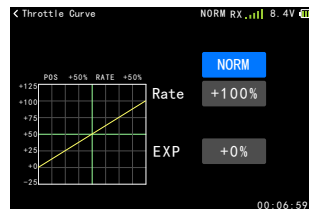

# ET10

# WFLY

Shenzhen WFLY Technology Development Co., LTD  
Address: 3th Floor, C3 Buliding, Xiangli Industry Park, Heping Haoye Road, Fuyog Town, Baoan District, Shenzhen, Guangdong Province, China.  
Tel: +86-755-29792496  
Tel: service@wflysz.com  
Website: www.wflysz.com

WFLY WeChat Official Account

